





W 14-2: Economic Solution for Standard Applications

	Photoelectric proximity switch BGB
	Photoelectric proximity switch energetic
	Photoelectric reflex switch



	Through-beam photoelectric switches
--	-------------------------------------

Teach-in function as well as the WL 14-2 photoelectric reflex switch and the WS/WE 14-2 through-beam photoelectric switch.

The ranges:

- WS/WE 14-2 through-beam photoelectric switch: 15 m,
- WL 14-2 photoelectric reflex switch: 6 m (PL 80 A), with polarizing filter,
- WT 14-2 photoelectric proximity switch with adjustable background blanking:
 - 80 ... 500 mm (infrared),
 - 50 ... 250 mm (red light),
- WT 14-2 Photoelectric proximity switch energetic with Teach-in function: 300 ... 1500 mm.

Detect and count conveyed objects in standard applications reliably and economically – and do it at economical prices – these are the two pivotal demands of market puts on a sensor for standard applications. The new W 14-2 photoelectric switch series fulfills these requirements market for standard sensors both from a technological and economical standpoint.

These sensors are used traditionally:

- Conveyor engineering,
- The packaging industry,
- Automation technology.

A choice of sensing techniques are available to handle your jobs with the photoelectric proximity switch with adjustable background blanking or energetic with

► WL 14-2 in the standard application package detection: the production process runs smoothly.

▼ In an empty bottle store, the WL 14-2 monitors the empty drinks crates and thus optimises the returns process.



▲ WT 14-2 reliably detects the pallet foot and monitors the correct transfer of goods in a warehouse.

◀ WT 14-2 detects the package flow on a fully-automatic packaging line.

Scanning distance
 80 ... 500 mm
 Photoelectric proximity switch

- Infrared light
- Background blanking, adjustable
- Sturdy plastic housing

Dimensional drawing

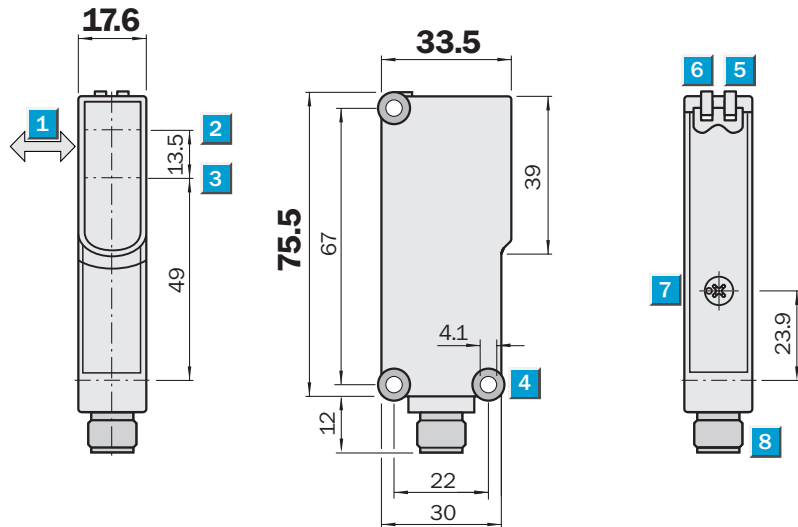

Adjustments possible

All types



- 1 Standard direction of the material being scanned
- 2 Optical axis sender
- 3 Optical axis receiver
- 4 Mounting hole \varnothing 4.1 mm
- 5 LED indicator, yellow; status of received light beam
- 6 LED indicator, green; power on
- 7 Scanning distance adjustment, Poti 4 turn
- 8 Plug M12, 4-pin or 2 m cable

Connection type

WT14-2P122	WT14-2P422
WT14-2N122	WT14-2N422

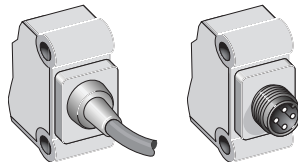

4 x 0.25 mm ²	4-pin, M12
--------------------------	------------

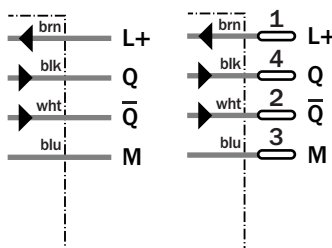

See chapter Accessories

Cables and connectors
Mounting systems

Technical data		WT14-2	P122	P422	N122	N422						
Scanning distance , adjustable ¹⁾	80 ... 500 mm, 90 % remission											
Visible range ¹⁾	20 ... 500 mm											
Adjustment	Via potentiometer, 4 turn											
Light source ²⁾, light type	LED, infrared light											
Light spot diameter	14 mm at 300 mm											
Supply voltage V_S	10 ... 30 V DC ³⁾											
Residual ripple ⁴⁾	< 5 V _{PP}											
Current consumption ⁵⁾	< 30 mA											
Output current I _A max.	< 100 mA											
Switching outputs	PNP, antivalent											
	NPN, antivalent											
Response time ⁶⁾	< 2.5 ms											
Max. switching frequency ⁷⁾	200/s											
Connection type	Cable ⁸⁾ PVC, 2 m, 4-wire											
	M12 plug, 4-pin											
VDE protection class ⁹⁾	<input type="checkbox"/>											
Circuit protection ¹⁰⁾	A, B, C, D											
Enclosure rating	IP 65											
Ambient temperature	Operation -25 °C ... +60 °C											
	Storage -40 °C ... +70 °C											
Weight	with cable	Approx. 120 g										
	with plug	Approx. 40 g										
Housing material	ABS											

¹⁾ Object with 90 % remission (based on standard white DIN 5033)
²⁾ Average service life 100,000 h at T_A = +25 °C

³⁾ Limit values; operation in short-circuit protected network max. 8 A
⁴⁾ May not exceed or fall short of V_S tolerances

⁵⁾ Without load
⁶⁾ Signal transit time with resistive load
⁷⁾ With light/dark ratio 1:1
⁸⁾ Do not bend below 0 °C

⁹⁾ Reference voltage 50 V DC
¹⁰⁾ A = V_S connections reverse-polarity protected
 B = Outputs Q and \bar{Q} short-circuit protected
 C = Interference pulse suppression
 D = Operation in short-circuit protected network max. 8A

Adjustment via potentiometer

1. Position the object in the path of the beam.
2. By rotating the potentiometer to the right until the yellow LED illuminates continuously = object is positively detected.
3. If necessary, fine adjustments to the scanning distance can be made to suit the conditions of the application: minimal rotation of the potentiometer to the right = scanning distance will be increased, minimal rotation of the potentiometer to the left = scanning distance will be decreased.

Scanning distance

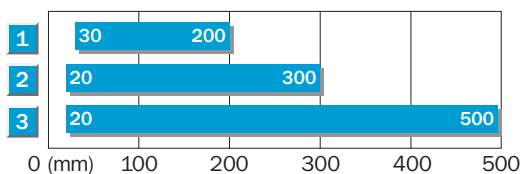

- 1 Scanning distance on black, 6 % remission
- 2 Scanning distance on grey, 18 % remission
- 3 Scanning distance on white, 90 % remission

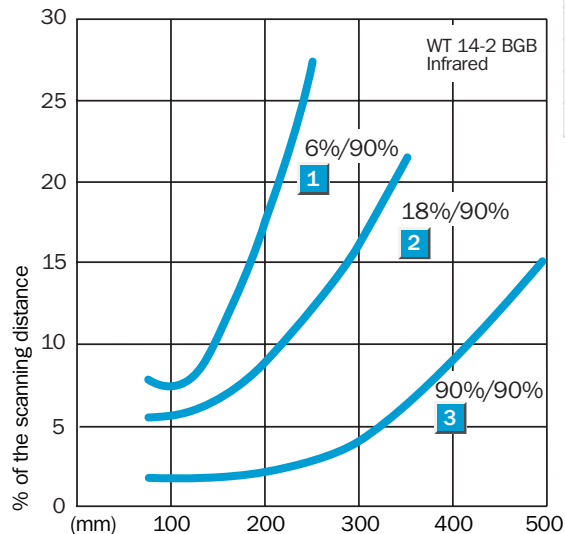

Order information

Type	Order no.
WT14-2P122	1 026 051
WT14-2P422	1 026 052
WT14-2N122	1 026 053
WT14-2N422	1 026 054

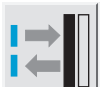
Scanning distance
 50 ... 250 mm
 Photoelectric proximity switch

- Red light
- Background blanking, adjustable
- Sturdy plastic housing

Dimensional drawing

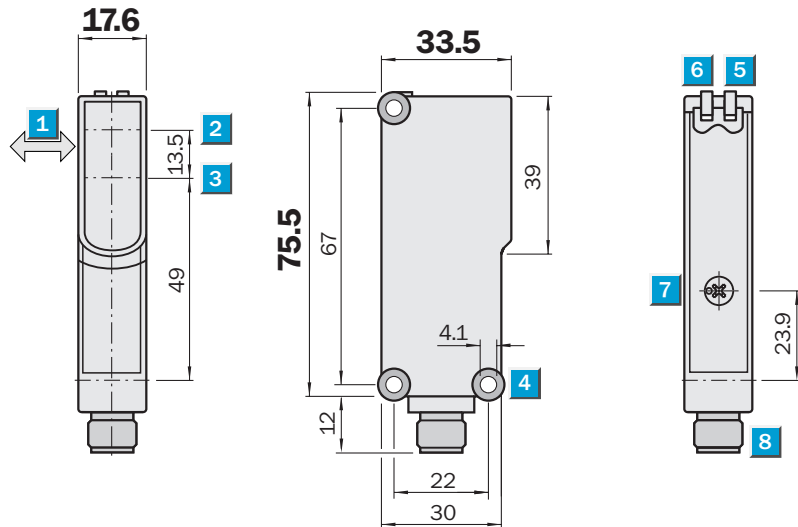

Adjustments possible

All types



- 1 Standard direction of the material being scanned
- 2 Optical axis sender
- 3 Optical axis receiver
- 4 Mounting hole \varnothing 4.1 mm
- 5 LED indicator, yellow; status of received light beam
- 6 LED indicator, green; power on
- 7 Scanning distance adjustment, Poti 4 turn
- 8 Plug M12, 4-pin or 2 m cable

Connection type

WT14-2P132	WT14-2P432
WT14-2N132	WT14-2N432

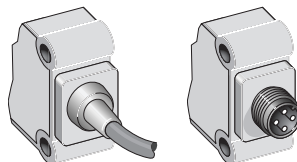

4 x 0.25 mm ²	4-pin, M12
--------------------------	------------

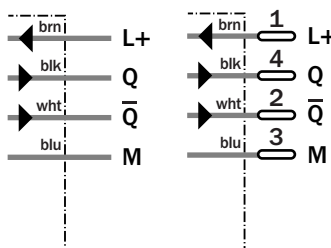

See chapter Accessories

Cables and connectors
Mounting systems

Technical data		WT14-2	P132	P432	N132	N432						
Scanning distance , adjustable ¹⁾	50 ... 250 mm, 90 % remission											
Visible range ¹⁾	20 ... 250 mm											
Adjustment	Via potentiometer, 4 turn											
Light source ²⁾, light type	LED, red light											
Light spot diameter	10 mm at 250 mm											
Supply voltage V_S	10 ... 30 V DC ³⁾											
Residual ripple ⁴⁾	< 5 V _{pp}											
Current consumption ⁵⁾	< 25 mA											
Output current I _A max.	< 100 mA											
Switching outputs	PNP, antivalent											
	NPN, antivalent											
Response time ⁶⁾	< 2.5 ms											
Max. switching frequency ⁷⁾	200/s											
Connection type	Cable ⁸⁾ PVC, 2 m, 4-wire											
	M12 plug, 4-pin											
VDE protection class ⁹⁾	<input type="checkbox"/>											
Circuit protection ¹⁰⁾	A, B, C, D											
Enclosure rating	IP 65											
Ambient temperature	Operation -25 °C ... +60 °C											
	Storage -40 °C ... +70 °C											
Weight	with cable	Approx. 120 g										
	with plug	Approx. 40 g										
Housing material	ABS											

- 1) Object with 90 % remission (based on standard white DIN 5033)
- 2) Average service life 100,000 h at T_A = +25 °C
- 3) Limit values; operation in short-circuit protected network max. 8 A
- 4) May not exceed or fall short of V_S tolerances
- 5) Without load
- 6) Signal transit time with resistive load
- 7) With light/dark ratio 1:1
- 8) Do not bend below 0 °C
- 9) Reference voltage 50 V DC
- 10) A = V_S connections reverse-polarity protected
 B = Outputs Q and \bar{Q} short-circuit protected
 C = Interference pulse suppression
 D = Operation in short-circuit protected network max. 8A

Adjustment via potentiometer

1. Position the object in the path of the beam.
2. By rotating the potentiometer to the right until the yellow LED illuminates continuously = object is positively detected.
3. If necessary, fine adjustments to the scanning distance can be made to suit the conditions of the application:
 minimal rotation of the potentiometer to the right = scanning distance will be increased,
 minimal rotation of the potentiometer to the left = scanning distance will be decreased.

Scanning distance

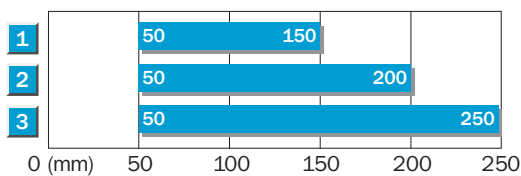

- 1 Scanning distance on black, 6 % remission
- 2 Scanning distance on grey, 18 % remission
- 3 Scanning distance on white, 90 % remission

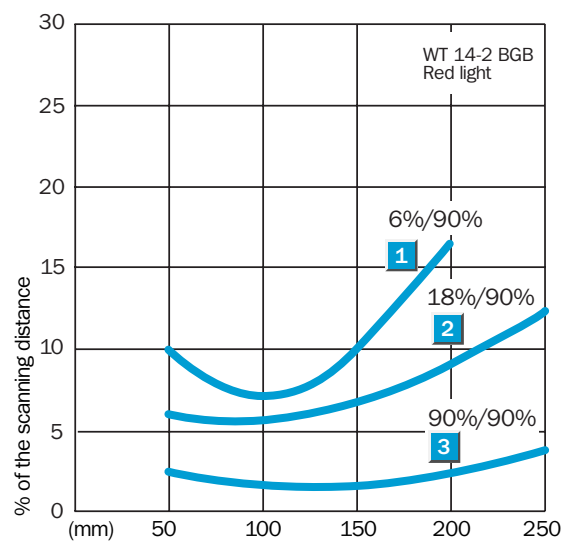

Order information

Type	Order no.
WT14-2P132	1 026 055
WT14-2P432	1 026 056
WT14-2N132	1 026 072
WT14-2N432	1 026 057

Scanning distance
300 ... 1500 mm

Photoelectric proximity switch

- Infrared light
- Energetic proximity switch
- Teach-in function
- Sturdy plastic housing

Dimensional drawing

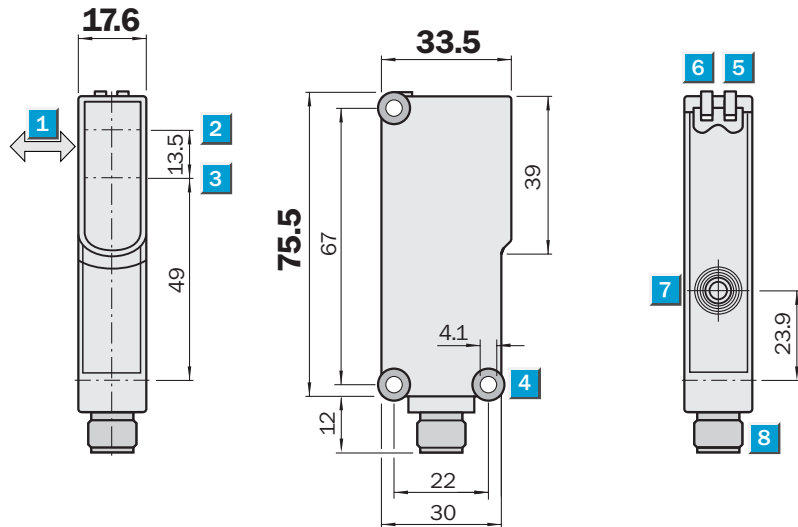

Adjustments possible

All types

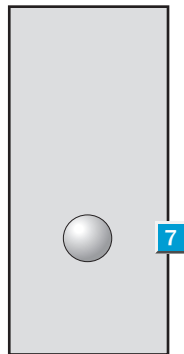

- 1 Standard direction of the material being scanned
- 2 Optical axis sender
- 3 Optical axis receiver
- 4 Mounting hole \varnothing 4.1 mm
- 5 LED indicator, yellow; status of received light beam
- 6 LED indicator, green; power on
- 7 Teach-in button
- 8 Plug M12, 4-pin or 2 m cable

Connection type

WT14-2P111	WT14-2P411
WT14-2N111	WT14-2N411

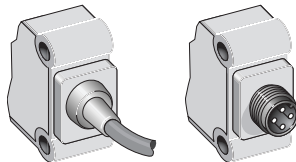

4 x 0.25 mm ²	4-pin, M12
--------------------------	------------

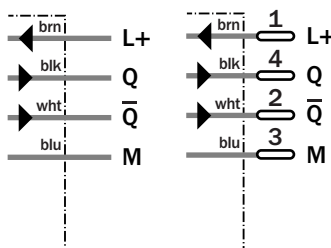

See chapter Accessories

Cables and connectors

Mounting systems

Technical data		WT14-2	P111	P411	N111	N411							
Scanning distance , adjustable ¹⁾	300 ... 1500 mm, 90 % remission												
Adjustment	Teach-in button												
Light source ²⁾ , light type	LED, infrared light												
Light spot diameter	56 mm at 1000 mm												
Supply voltage V _S	10 ... 30 V DC ³⁾												
Residual ripple ⁴⁾	< 5 V _{PP}												
Current consumption ⁵⁾	≤ 55 mA												
Output current I _A max.	< 100 mA												
Switching outputs	PNP, antivalent												
	NPN, antivalent												
Response time ⁶⁾	≤ 2.5 ms												
Max. switching frequency ⁷⁾	200/s												
Connection type	Cable ⁸⁾ PVC, 2 m, 4-wire												
	M12 plug, 4-pin												
VDE protection class ⁹⁾	<input type="checkbox"/>												
Circuit protection ¹⁰⁾	A, B, C, D												
Enclosure rating	IP 65												
Ambient temperature	Operation -25 °C ... +60 °C												
	Storage -40 °C ... +70 °C												
Weight	with cable	Approx. 120 g											
	with plug	Approx. 40 g											
Housing material	ABS												

- ¹⁾ Object with 90 % remission (based on standard white DIN 5033)
- ²⁾ Average service life 100,000 h at T_A = +25 °C
- ³⁾ Limit values; operation in short-circuit protected network max. 8 A
- ⁴⁾ May not exceed or fall short of V_S tolerances
- ⁵⁾ Without load
- ⁶⁾ Signal transit time with resistive load
- ⁷⁾ With light/dark ratio 1:1
- ⁸⁾ Do not bend below 0 °C
- ⁹⁾ Reference voltage 50 V DC
- ¹⁰⁾ A = V_S connections reverse-polarity protected
 B = Outputs Q and \bar{Q} short-circuit protected
 C = Interference pulse suppression
 D = Operation in short-circuit protected network max. 8 A

Teach-in function

- **Programming via Teach-in button.**
- **Simple programming:**
 position object in light beam,
 press button, finished;
 LED confirms the successful Teach-in procedure.
- **Teach-in value is stored.**
- **Two operating modes:**
Default setting: short Teach-in time (< 6 s),
 For standard applications;
 Approx. double reserve via switching threshold;
 LED lights.
- Precise setting:** long Teach-in time (> 8 s);
 For precise applications;
 Slight reserve via switching threshold;
 LED blinks when operating reserve > 2 (see graphic).

Scanning distance

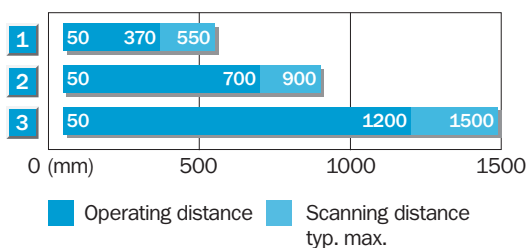

- 1 Scanning distance on black, 6 % remission
- 2 Scanning distance on grey, 18 % remission
- 3 Scanning distance on white, 90 % remission

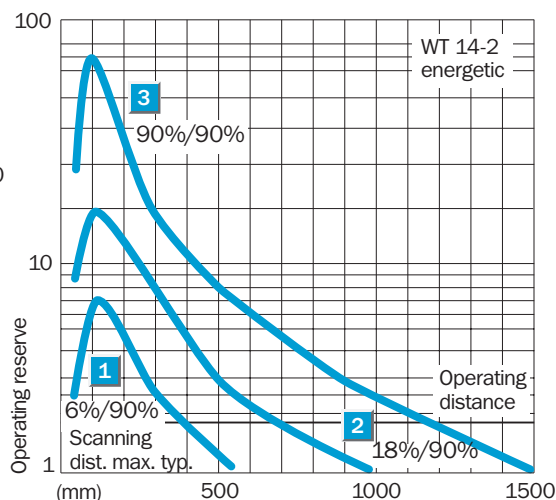

Order information

Type	Order no.
WT14-2P111	1 026 058
WT14-2P411	1 026 059
WT14-2N111	1 026 060
WT14-2N411	1 026 062

Scanning range
6 m

Photoelectric reflex switch

- Red light
- Polarisation filter which permits the reliable detection of objects with shiny surfaces
- Sturdy plastic housing

Dimensional drawing

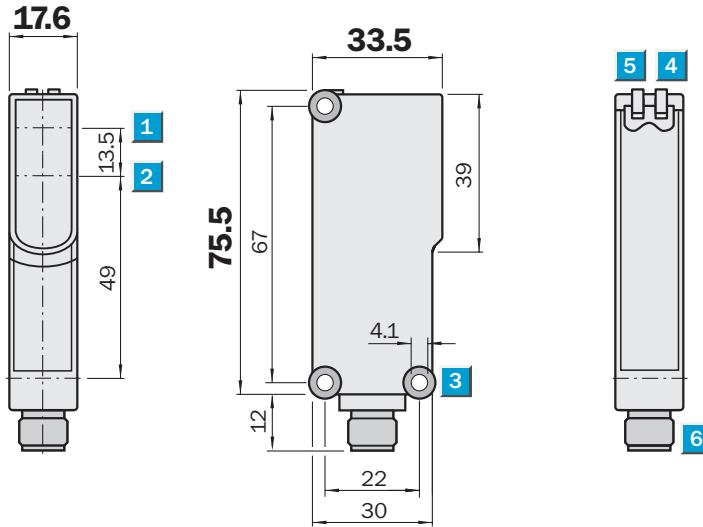

- 1 Optical axis sender
- 2 Optical axis receiver
- 3 Mounting holes \varnothing 4.1 mm
- 4 LED indicator, yellow; status of received light beam
- 5 LED indicator, green; power on
- 6 Plug M12, 4-pin or 2 m cable

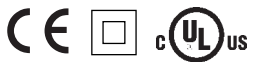

Connection type

WL14-2P130	WL14-2P430
WL14-2N130	WL14-2N430

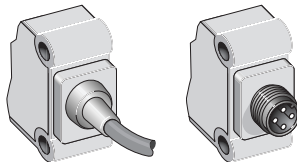

4 x 0.25 mm² 4-pin, M12

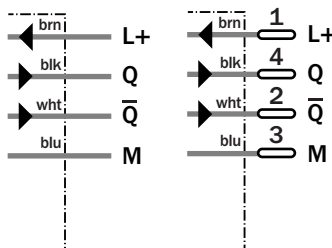

See chapter Accessories

- Cables and connectors
- Mounting systems
- Reflectors

Technical data		WL14-2	P130	P430	N130	N430							
Scanning range , typ. max./on reflector	6 m/PL 80 A												
Light source ¹⁾ , light type	LED, red light												
Opening angle	2°												
Light spot diameter	140 mm at 4 m												
Polarising filter	Yes												
Supply voltage V _S	10 ... 30 V DC ²⁾												
Residual ripple ³⁾	≤ 5 V _{PP}												
Current consumption ⁴⁾	≤ 35 mA												
Output current I _A max.	< 100 mA												
Switching outputs	PNP, antivalent												
	NPN, antivalent												
Response time ⁵⁾	≤ 2.5 ms												
Max. switching frequency ⁶⁾	200/s												
Connection type	Cable ⁷⁾ PVC, 2 m, 4-wire												
	M12 plug, 4-pin												
VDE protection class ⁸⁾	□												
Circuit protection ⁹⁾	A, B, C												
Enclosure rating	IP 65												
Ambient temperature	Operation -25 °C ... +60 °C												
	Storage -40 °C ... +70 °C												
Weight	with cable	Approx. 120 g											
	with plug	Approx. 40 g											
Housing material	ABS												

¹⁾ Average service life 100,000 h at T_A = +25 °C

²⁾ Limit values; operation in short-circuit protected network max. 8 A

³⁾ May not exceed or fall short of V_S tolerances

⁴⁾ Without load

⁵⁾ Signal transit time with resistive load

⁶⁾ With light/dark ratio 1:1

⁷⁾ Do not bend below 0 °C

⁸⁾ Reference voltage 50 V DC

⁹⁾ A = V_S connections reverse-polarity protected

B = Outputs Q and \bar{Q} short-circuit protected

C = Interference pulse suppression

Scanning range

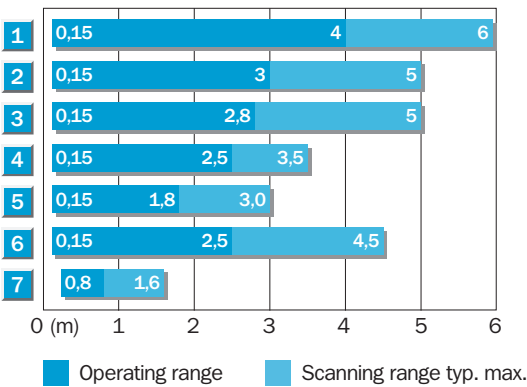

Reflector type	Operating range
1 PL 80 A	0,15 ... 4 m
2 PL 50 A	0,15 ... 3 m
3 PL 40 A	0,15 ... 2,8 m
4 PL 30 A	0,15 ... 2,5 m
5 PL 20 A	0,15 ... 1,8 m
6 C 110	0,15 ... 2,5 m
7 Reflective tape Diamond Grade	0,3 ... 0,8 m

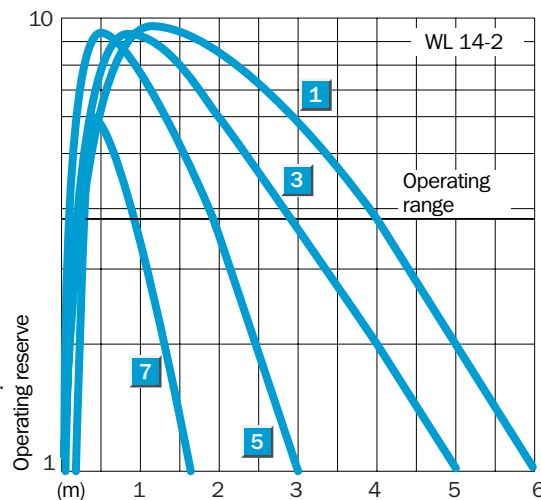

Order information

Type	Order no.
WL14-2P130	1 026 050
WL14-2P430	1 026 049
WL14-2N130	1 026 047
WL14-2N430	1 026 048

Scanning range
15 m

Through-beam photoelectric switches

- Red light
- Test input for system diagnostics
- Sturdy plastic housing

Dimensional drawing

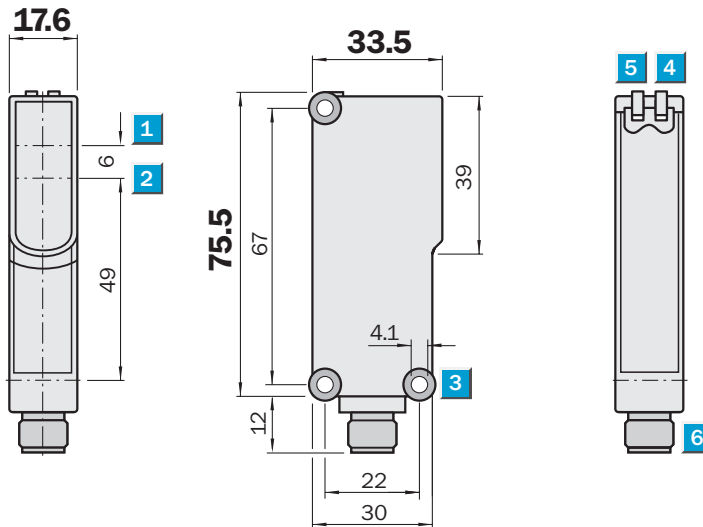

- 1 Optical axis sender (only WS)
- 2 Optical axis receiver (only WE)
- 3 Mounting holes Ø 4.1 mm
- 4 LED indicator, yellow; status of received light beam
- 5 LED indicator, green; power on
- 6 Plug M12, 4-pin or 2 m cable

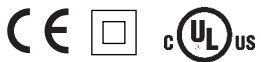

Connection type

WS/WE14-2P130	WS/WE14-2P430
WS/WE14-2N130	WS/WE14-2N430

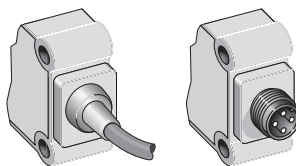

3/4 x 0.25 mm² 4-pin, M12

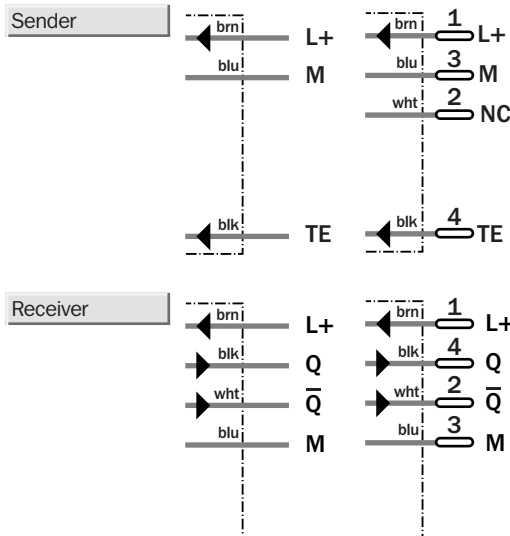

See chapter Accessories

- Cables and connectors
- Mounting systems

Technical data		WS/WE14-2	P130	P430	N130	N430						
Scanning range, typ. max.	0 ... 15 m											
Light source ¹⁾ , light type	LED, red light											
Light spot diameter	300 mm at 10 m											
Supply voltage V_S	10 ... 30 V DC ²⁾											
Residual ripple ³⁾	$\leq 5 V_{PP}$											
Current consumption ⁴⁾	≤ 60 mA											
Sender	≤ 35 mA											
Receiver	≤ 25 mA											
Output current I_A max.	< 100 mA											
Switching outputs	PNP, antivalent											
	NPN, antivalent											
Response time ⁵⁾	≤ 2.5 ms											
Max. switching frequency ⁶⁾	200/s											
Test input »TE« sender off	TE to 0 V											
Connection type	Cable ⁷⁾ PVC, 2 m, 3-/4-wire											
	M12 plug, 4-pin											
VDE protection class ⁸⁾	<input type="checkbox"/>											
Circuit protection ⁹⁾	A, B, C											
Enclosure rating	IP 65											
Ambient temperature	Operation	-25 °C ... +60 °C										
	Storage	-40 °C ... +70 °C										
Weight	with cable	Approx. 120 g										
	with plug	Approx. 40 g										
Housing material	ABS											

¹⁾ Average service life 100,000 h at $T_A = +25$ °C

²⁾ Limit values; operation in short-circuit protected network max. 8 A

³⁾ May not exceed or fall short of V_S tolerances

⁴⁾ Without load

⁵⁾ Signal transit time with resistive load

⁶⁾ With light/dark ratio 1:1

⁷⁾ Do not bend below 0 °C

⁸⁾ Reference voltage 50 V DC

⁹⁾ A = V_S connections reverse-polarity protected

B = Outputs Q and \bar{Q} short-circuit protected

C = Interference pulse suppression

Scanning range and operating reserve

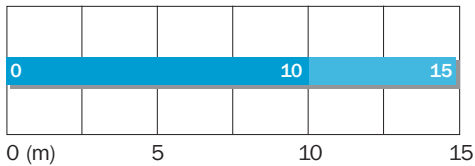

■ Operating range ■ Scanning range typ. max.

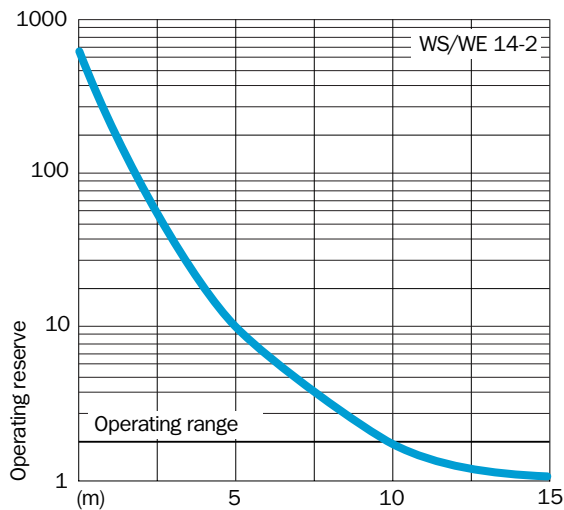

Order information

Type	Order no.
WS/WE14-2P130	1 026 430
WS/WE14-2P430	1 026 431
WS/WE14-2N130	1 026 432
WS/WE14-2N430	1 026 433