

JUMO GmbH & Co. KG

Delivery address: Mackenrodtstraße 14,
36039 Fulda, Germany
Postal address: 36035 Fulda, Germany
Phone: +49 661 6003-0
Fax: +49 661 6003-607
e-mail: mail@jumo.net
Internet: www.jumo.net

JUMO Instrument Co. Ltd.

JUMO House
Temple Bank, Riverway
Harlow, Essex CM 20 2TT, UK
Phone: +44 1279 635533
Fax: +44 1279 635262
e-mail: sales@jumo.co.uk
Internet: www.jumo.co.uk

JUMO Process Control, Inc.

8 Technology Boulevard
Canastota, NY 13032, USA
Phone: 315-697-JUMO
1-800-554-JUMO
Fax: 315-697-5867
e-mail: info@jumo.us
Internet: www.jumo.us



Timers

- with mechanical drive or synchronous motor
- with acoustic signal and two contacts
- housing size: 60 mm dia.
bezel sizes: 72 x 72 mm and 96 x 96 mm

Brief description

Timers with mechanical drive and acoustic signal (switch function 00)

Turning the selector knob winds up the clockwork mechanism. At the end of the pre-set time, there is an acoustic signal.

Timer with mechanical drive and two changeover contacts (switch function 26)

Turning the selector knob winds up the clockwork mechanism. At the end of the pre-set time, electrical equipment and installations can be switched on/off or over. In addition, acoustic or optical signals can be operated through a contact.

After the set time has elapsed, contacts I and II change over and, at the same time, the selector knob returns to its start position.

Timer with synchronous motor and two contacts (switch function 24 and 25)

Turning the selector knob will switch on the synchronous motor of the timer and pre-select the time. During the set time, or after it has elapsed, electrical equipment and installations can be switched on/off or over. In addition, acoustic or optical signals can be operated through a contact.

Switch function 24

After the set time has elapsed, contacts I and III change over (contact II opens). Contacts I and III must be returned manually to the start position, by turning the selector knob from "0" to "Off" (contact II remains open).

Switch function 25

90 sec before the end of the pre-set time, contact II will be closed for approx. 90 sec. After the set time has elapsed, contacts I and II are opened (automatic signal switch-off for contact II).



Type 608901/5172



Type 608901/5272



Type 608901/5460

JUMO GmbH & Co. KG
 Delivery address: Mackenrodtstraße 14,
 36039 Fulda, Germany
 Postal address: 36035 Fulda, Germany
 Phone: +49 661 6003-0
 Fax: +49 661 6003-607
 e-mail: mail@jumo.net
 Internet: www.jumo.net

JUMO Instrument Co. Ltd.
 JUMO House
 Temple Bank, Riverway
 Harlow, Essex CM 20 2TT, UK
 Phone: +44 1279 635533
 Fax: +44 1279 635262
 e-mail: sales@jumo.co.uk
 Internet: www.jumo.co.uk

JUMO Process Control, Inc.
 8 Technology Boulevard
 Canastota, NY 13032, USA
 Phone: 315-697-JUMO
 1-800-554-JUMO
 Fax: 315-697-5867
 e-mail: info@jumo.us
 Internet: www.jumo.us



Technical data

	Basic type extension 5172 and 5196	Basic type extension 5272 and 5296	Basic type extension 5460
Housing	black plastic		--
Housing mounting	from the back, with bracket		front
Scale	white, black lettering		
Timer setting	By selector knob on the front window. Minimum setting angle 30°. Very short times can be selected by moving the knob beyond the desired setting and then turning it back again. Timer setting by:		
Time marking	black knob with plastic flange by arrow on flange	black knob with aluminium disc in center by pointer	
Baseplate	housing size 72 x 72 mm: plastic housing size 96 x 96 mm: sheet steel, zinc-plated		sheet steel, zinc-plated
Bezel	plastic		stainless steel, electro-polished, for front mounting
Electrical contact connection rating	faston connector A 6.3 x 0.8 to DIN 46244		
operating voltage of synchronous motor	16 (4) A, 230V AC +10/-15%, 48 – 63Hz, p.f. = 1 (0.6) 10 (2) A, 380V AC +10/-15%, 48 – 63Hz, p.f. = 1 (0.6)		
Limit temperatures	230V AC, 50 Hz		
Nominal position (NL)	Permissible ambient temperature -20 to +80°C unrestricted		
	Switch function 00	Switch function 24	Switch function 25
Scale span °↺	270	300 + 30	300
Deviation (minutes)			
30 min	--	--	± 1.5
60 min	± 0.5	± 2.0	± 3.0

Dimensions

Type: 608901/5172-00

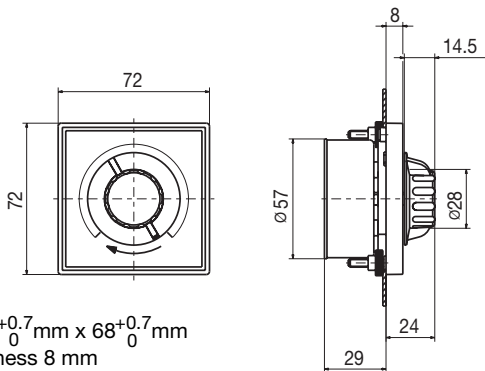

Type: 608901/5196-00

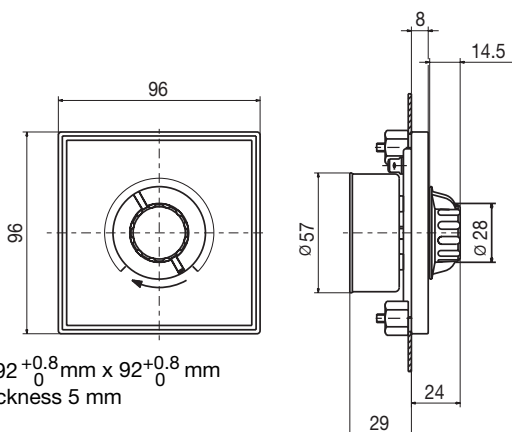

JUMO GmbH & Co. KG
 Delivery address: Mackenrodtstraße 14,
 36039 Fulda, Germany
 Postal address: 36035 Fulda, Germany
 Phone: +49 661 6003-0
 Fax: +49 661 6003-607
 e-mail: mail@jumo.net
 Internet: www.jumo.net

JUMO Instrument Co. Ltd.
 JUMO House
 Temple Bank, Riverway
 Harlow, Essex CM 20 2TT, UK
 Phone: +44 1279 635533
 Fax: +44 1279 635262
 e-mail: sales@jumo.co.uk
 Internet: www.jumo.co.uk

JUMO Process Control, Inc.
 8 Technology Boulevard
 Canastota, NY 13032, USA
 Phone: 315-697-JUMO
 1-800-554-JUMO
 Fax: 315-697-5867
 e-mail: info@jumo.us
 Internet: www.jumo.us



Dimensions

Type: 608901/5172-26

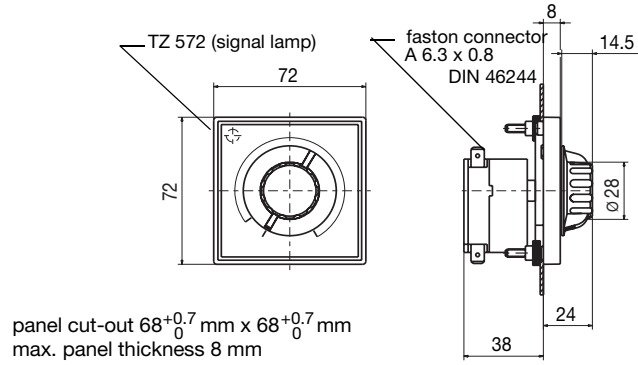

Type: 608901/5196-26

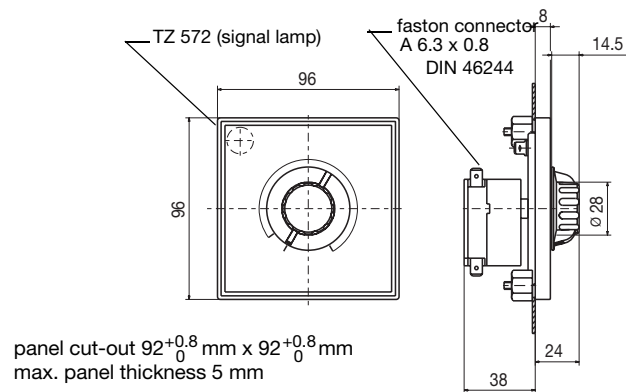

Type: 608901/5172-24
 608901/5172-25

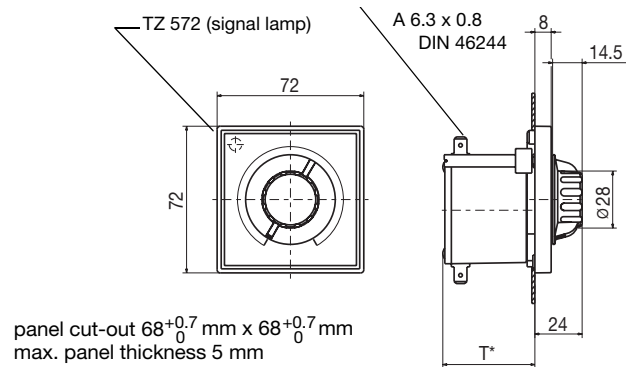

Type: 608901/5196-24
 608901/5196-25

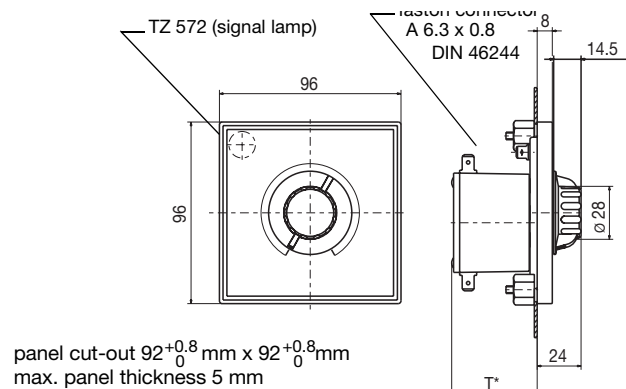

* Switch function	T (mm)
24	56
25	45

JUMO GmbH & Co. KG
 Delivery address: Mackenrodtstraße 14,
 36039 Fulda, Germany
 Postal address: 36035 Fulda, Germany
 Phone: +49 661 6003-0
 Fax: +49 661 6003-607
 e-mail: mail@jumo.net
 Internet: www.jumo.net

JUMO Instrument Co. Ltd.
 JUMO House
 Temple Bank, Riverway
 Harlow, Essex CM 20 2TT, UK
 Phone: +44 1279 635533
 Fax: +44 1279 635262
 e-mail: sales@jumo.co.uk
 Internet: www.jumo.co.uk

JUMO Process Control, Inc.
 8 Technology Boulevard
 Canastota, NY 13032, USA
 Phone: 315-697-JUMO
 1-800-554-JUMO
 Fax: 315-697-5867
 e-mail: info@jumo.us
 Internet: www.jumo.us



Dimensions

Type: 608901/5272-24
 608901/5272-25

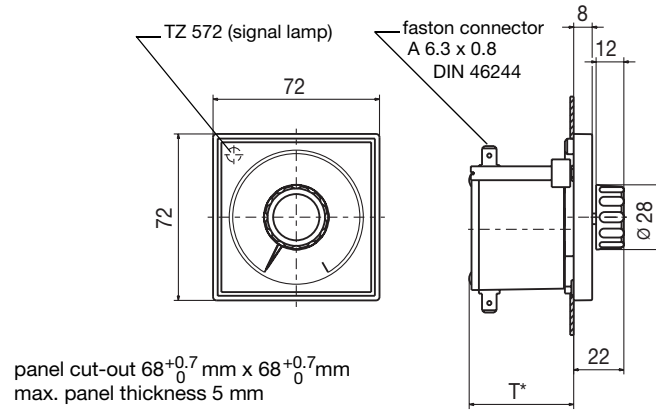

Type: 608901/5296-24
 608901/5296-25

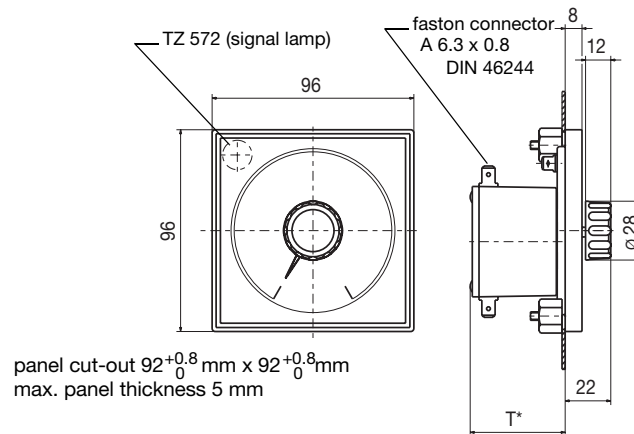

* Switch function	T (mm)
24	56
25	45

Type: 608901/5460-00

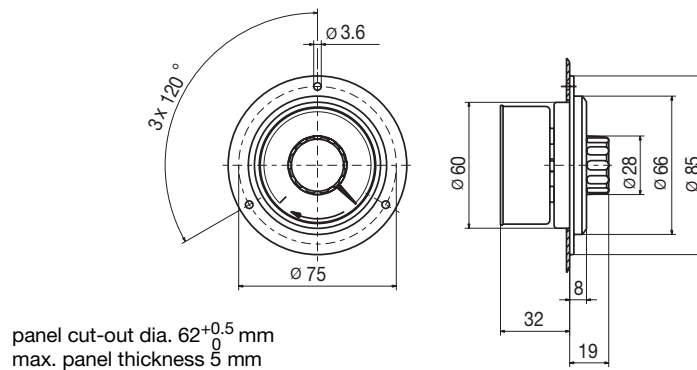

JUMO GmbH & Co. KG
 Delivery address: Mackenrodtstraße 14,
 36039 Fulda, Germany
 Postal address: 36035 Fulda, Germany
 Phone: +49 661 6003-0
 Fax: +49 661 6003-607
 e-mail: mail@jumo.net
 Internet: www.jumo.net

JUMO Instrument Co. Ltd.
 JUMO House
 Temple Bank, Riverway
 Harlow, Essex CM 20 2TT, UK
 Phone: +44 1279 635533
 Fax: +44 1279 635262
 e-mail: sales@jumo.co.uk
 Internet: www.jumo.co.uk

JUMO Process Control, Inc.
 8 Technology Boulevard
 Canastota, NY 13032, USA
 Phone: 315-697-JUMO
 1-800-554-JUMO
 Fax: 315-697-5867
 e-mail: info@jumo.us
 Internet: www.jumo.us



Order details Timers Type 608901

		(1) Basic type			Preis EUR
		608901	timer, mechanical		
		608901	timer, with synchronous motor		
(2) Basic type extension					
X	X	5172	style: 51; housing size: 72 x 72 mm		
X	X	5196	style: 51; housing size: 96 x 96 mm		
	X	5272	style: 52; housing size: 72 x 72 mm		
	X	5296	style: 52; housing size: 96 x 96 mm		
	X	5460	style: 54; housing size: 60 mm dia.		
(3) Switch function					
X		00	acoustic signal		
	X	24	2 changeover contacts and manual signal switch-off	 	
	X	25	2 make (n.o) contacts	 	
	X	26	2 changeover contacts (style 51 only)	 	
(4) Running time					
X		30	30 minutes (switch function 26 only)		
X	X	60	60 minutes		
(5) Extra codes					
X	X	000	no extra code		
X	X	410	metal bezel, black (not on style 54)		
X	X	411	metal bezel		
X	X	572	signal lamp (not on style 54; not with switch function 00)		
X	X	521	black scale, white lettering		
X	X	522	scale to customer specification		
X	X	480	gray knob (style 51 only)		

Order code

(1) / (2) - (3) - (4) / (5) , ...
 608901 / ... - .. - .. / ... , ...

Order example

608901 / 5196 - 25 - 60 / 000¹

¹ List extra codes in sequence, separated by commas.