

JUMO GmbH & Co. KG
 Delivery address: Mackenrodtstraße 14,
 36039 Fulda, Germany
 Postal address: 36035 Fulda, Germany
 Phone: +49 661 6003-0
 Fax: +49 661 6003-607
 e-mail: mail@jumo.net
 Internet: www.jumo.net

JUMO Instrument Co. Ltd.
 JUMO House
 Temple Bank, Riverway
 Harlow, Essex CM 20 2TT, UK
 Phone: +44 1279 635533
 Fax: +44 1279 635262
 e-mail: sales@jumo.co.uk
 Internet: www.jumo.co.uk

JUMO Process Control, Inc.
 8 Technology Boulevard
 Canastota, NY 13032, USA
 Phone: 315-697-JUMO
 1-800-554-JUMO
 Fax: 315-697-5867
 e-mail: info@jumo.us
 Internet: www.jumo.us



MICROSTAT-M

- Electromechanical temperature controller with indication
- Class 1.5 with one microswitch
- IP53 front protection
- Housing sizes: 60 mm, 80 mm and 100 mm dia.
 Bezel sizes: 72 x 72 mm and 96 x 96 mm

Brief description

The MICROSTAT-M is an electromechanical temperature controller with indication for universal use. The instrument has a steel housing and a liquid-filled or gas-filled measuring system.

The temperature-dependent change in volume of a liquid-filled measuring system, or the temperature-dependent change in pressure of a gas-filled system, is converted by a Bourdon tube into a rotary movement of the pointer, without any transmission gearing. The rotary movement of the pointer spindle operates the microswitch through a lever system.



Type 608510/2160

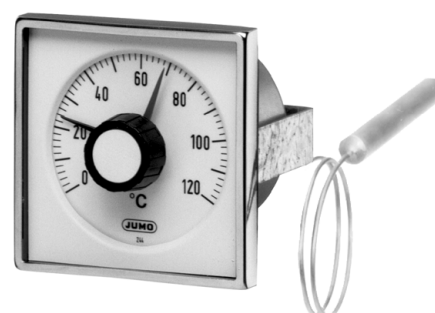

Type 608510/2572

Technical data

Housing or bezel	zinc-plated steel, with metal bezel; housing mounted at the rear by a bracket (not for style 20)		
Protection	front: IP53 to EN 60 529 (IP54 with extra code 489) rear: IP00 to EN 60 529 (IP54 with extra code 426)		
Scale	white, black lettering		
Accuracy class	Class 1.5 similar to EN 13 190		
Measuring system	liquid-filled	gas-filled	
	indication range $\leq 350^{\circ}\text{C}$	indication range $\geq 400^{\circ}\text{C}$	
Time constant $t_{0.632}$	approx. 12 sec, measured in water bath, with a 6 mm dia. copper probe	approx. 2 sec, measured in an oil bath, with a 10 mm dia. stainless steel probe.	
Ambient temperature error effect	in % of indication range (referred to the deviation from the reference value $+23^{\circ}\text{C}$)		
on housing	0.15% of indication range per $^{\circ}\text{C}$ change in ambient temperature	approx. 4 sec, measured in oil bath, with a 10 mm dia. stainless steel probe	
on capillary (per meter)	0.03% of indication range per $^{\circ}\text{C}$ change in ambient temperature	no effect	
	higher ambient temperature – higher temperature indication – lower switching point		
	standard	extra code (TZ) 651	extra code (TZ) 650
Electrical contact	single-pole microswitch with a mechanically operated changeover contact		
Contact type			
Contact rating	230 V AC $\pm 10\%$ -15%, 48 – 63 Hz, p.f. = 1 (0.6)		
	5 (1.5) A	3 (1) A	10 (3) A
Switching differential	approx. 1.5% of indication range		1.5 to 3% of indication range
Switching point accuracy	$\pm 0.5\%$ of indication range span referred to the switch-off point with rising temperature		
Switching reliability	To ensure maximum switching reliability, we recommend a minimum voltage of 24 V and a minimum current of 20 mA.		
	standard	extra code (TZ) 507	
Electrical connection	faston connectors A 6.3 x 0.8 to DIN 46244	screw terminals: for cable up to 1.5 mm ² conductor cross-section	
Setpoint adjustment	by setting device on the window		
Limit temperatures	for transport and storage: -20 to $+70^{\circ}\text{C}$ (for indication range -40 to $+40^{\circ}\text{C}$: up to 50°C ; for indication range -30 to $+50^{\circ}\text{C}$: up to 60°C)		
Nominal position	unrestricted		

JUMO GmbH & Co. KG
 Delivery address: Mackenrodtstraße 14,
 36039 Fulda, Germany
 Postal address: 36035 Fulda, Germany
 Phone: +49 661 6003-0
 Fax: +49 661 6003-607
 e-mail: mail@jumo.net
 Internet: www.jumo.net

JUMO Instrument Co. Ltd.
 JUMO House
 Temple Bank, Riverway
 Harlow, Essex CM 20 2TT, UK
 Phone: +44 1279 635533
 Fax: +44 1279 635262
 e-mail: sales@jumo.co.uk
 Internet: www.jumo.co.uk

JUMO Process Control, Inc.
 8 Technology Boulevard
 Canastota, NY 13032, USA
 Phone: 315-697-JUMO
 1-800-554-JUMO
 Fax: 315-697-5867
 e-mail: info@jumo.us
 Internet: www.jumo.us



Dimensions

Type: 608510/2160

Width of mounting bracket

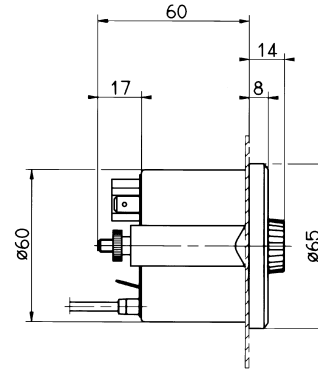
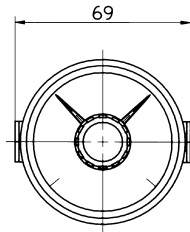

Panel cut-out $\varnothing 62 \begin{smallmatrix} +0.5 \\ 0 \end{smallmatrix}$ mm

Type: 608510/2572

Width of mounting bracket

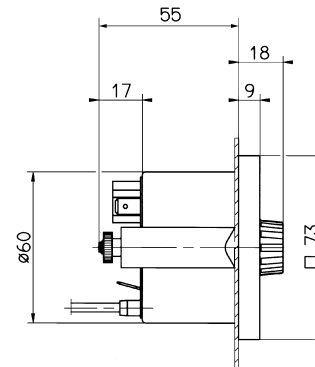
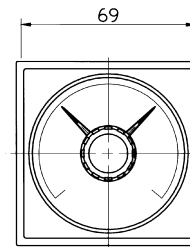

Panel cut-out $\varnothing 62 \begin{smallmatrix} +0.5 \\ 0 \end{smallmatrix}$ mm

Type: 608510/2180

Width of mounting bracket

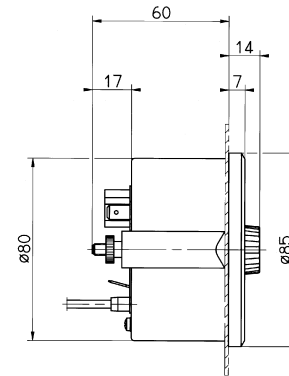
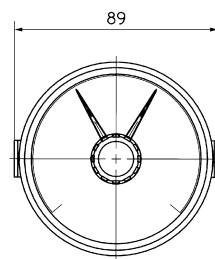

Panel cut-out $\varnothing 82 \begin{smallmatrix} +0.5 \\ 0 \end{smallmatrix}$ mm

Type: 608510/2596

Width of mounting bracket

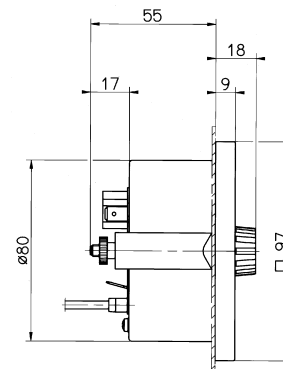
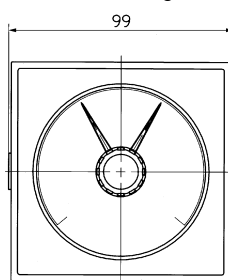

Panel cut-out $\varnothing 82 \begin{smallmatrix} +0.5 \\ 0 \end{smallmatrix}$ mm or $92 \times 92 \begin{smallmatrix} +0.8 \\ 0 \end{smallmatrix}$ mm (TZ 460)

JUMO GmbH & Co. KG
 Delivery address: Mackenrodtstraße 14,
 36039 Fulda, Germany
 Postal address: 36035 Fulda, Germany
 Phone: +49 661 6003-0
 Fax: +49 661 6003-607
 e-mail: mail@jumo.net
 Internet: www.jumo.net

JUMO Instrument Co. Ltd.
 JUMO House
 Temple Bank, Riverway
 Harlow, Essex CM 20 2TT, UK
 Phone: +44 1279 635533
 Fax: +44 1279 635262
 e-mail: sales@jumo.co.uk
 Internet: www.jumo.co.uk

JUMO Process Control, Inc.
 8 Technology Boulevard
 Canastota, NY 13032, USA
 Phone: 315-697-JUMO
 1-800-554-JUMO
 Fax: 315-697-5867
 e-mail: info@jumo.us
 Internet: www.jumo.us



Dimensions

Type: 608510/2110

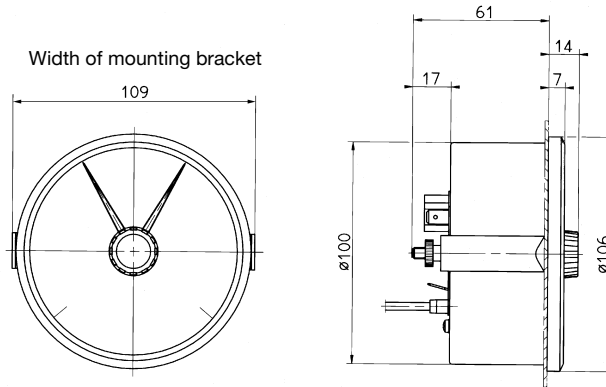

Panel cut-out $\varnothing 102 \begin{matrix} +0.5 \\ 0 \end{matrix}$ mm

Types: 608510/2060
 608510/2080
 608510/2010

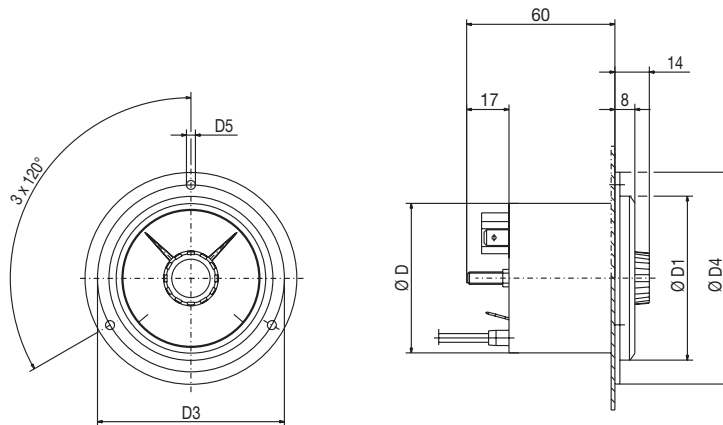

Type	$\varnothing D$	$\varnothing D1$	$\varnothing D3$	$\varnothing D4$	$\varnothing D5$	Panel cut-out $\varnothing \begin{matrix} +0.5 \\ 0 \end{matrix}$ mm
	(mm)					
608510/2060	60	66	75	85	3.6	62
608510/2080	80	86	95	110	4.8	82
608510/2010	100	107	116	132	4.8	102

Extra code 426

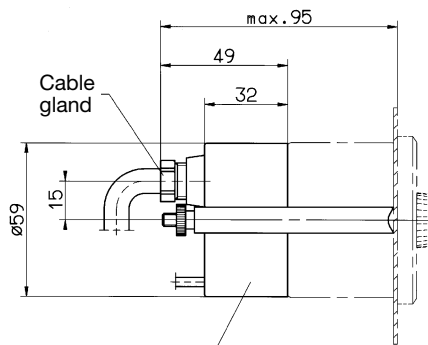

Extra code TZ 426

JUMO GmbH & Co. KG
 Delivery address: Mackenrodtstraße 14,
 36039 Fulda, Germany
 Postal address: 36035 Fulda, Germany
 Phone: +49 661 6003-0
 Fax: +49 661 6003-607
 e-mail: mail@jumo.net
 Internet: www.jumo.net

JUMO Instrument Co. Ltd.
 JUMO House
 Temple Bank, Riverway
 Harlow, Essex CM 20 2TT, UK
 Phone: +44 1279 635533
 Fax: +44 1279 635262
 e-mail: sales@jumo.co.uk
 Internet: www.jumo.co.uk

JUMO Process Control, Inc.
 8 Technology Boulevard
 Canastota, NY 13032, USA
 Phone: 315-697-JUMO
 1-800-554-JUMO
 Fax: 315-697-5867
 e-mail: info@jumo.us
 Internet: www.jumo.us



Order details

MICROSTAT-M Type 608510

Order code	(1) Basic type
608510	Electromechanical temperature controller MICROSTAT-M, Class 2, with one microswitch
(2) Basic type extensions	
2060	Style: 20; housing size: 60 mm dia.
2080	Style: 20; housing size: 80 mm dia.
2010	Style: 20; housing size: 100 mm dia.
2160	Style: 21; housing size: 60 mm dia.
2180	Style: 21; housing size: 80 mm dia.
2110	Style: 21; housing size: 100 mm dia.
2572	Style: 25; housing size: 72 x 72 mm
2596	Style: 25; housing size: 96 x 96 mm
(3) Indication range (AB)	
469	-40 to + 40°C; measuring range -30 to + 30°C, accuracy 1.5°C
566	-30 to + 50°C; measuring range -20 to + 40°C, accuracy 1.5°C
643	-20 to +120°C; measuring range 0 to +100°C, accuracy 3.0°C
807	0 to + 60°C; measuring range +10 to + 50°C, accuracy 1.5°C
810	0 to + 80°C; measuring range +10 to + 70°C, accuracy 1.5°C
814	0 to +100°C; measuring range +10 to + 90°C, accuracy 1.5°C
818	0 to +120°C; measuring range +20 to +100°C, accuracy 3.0°C
826	0 to +160°C; measuring range +20 to +140°C, accuracy 3.0°C
832	0 to +200°C; measuring range +20 to +180°C, accuracy 3.0°C
834	0 to +250°C; measuring range +30 to +220°C, accuracy 4.0°C
926	+50 to +250°C; measuring range +70 to +230°C, accuracy 3.0°C
840	0 to +300°C; measuring range +30 to +270°C, accuracy 6.0°C
927	+50 to +300°C; measuring range +80 to +270°C, accuracy 4.0°C
843	0 to +350°C; measuring range +50 to +300°C, accuracy 6.0°C
932	+50 to +350°C; measuring range +80 to +320°C, accuracy 6.0°C
848	0 to +400°C; measuring range +50 to +350°C, accuracy 6.0°C
851	0 to +450°C; measuring range +50 to +400°C, accuracy 6.0°C
854	0 to +500°C; measuring range +50 to +450°C, accuracy 8.0°C
858	0 to +600°C; measuring range +100 to +500°C, accuracy 10.0°C
(4) Capillary type (FL)¹	
02	FL02 copper capillary with copper braiding, approx. 2.5 mm dia. (up to +300°C top of indication range)
11	FL11 copper capillary with PE sleeve, approx. 3.5 mm dia. (up to +120°C top of indication range)
17	FL17 stainless steel capillary, 1.5 mm dia.
21	FL21 copper capillary, 1.0 mm dia. (up to +300°C top of indication range)
(5) Capillary length¹	
1000	1000 mm
2000	2000 mm
3000	3000 mm
4000	4000 mm
5000	5000 mm
...	special length (specify in plain text: in 1000 mm steps, maximum length: 10000 mm)

JUMO GmbH & Co. KG
 Delivery address: Mackenrodtstraße 14,
 36039 Fulda, Germany
 Postal address: 36035 Fulda, Germany
 Phone: +49 661 6003-0
 Fax: +49 661 6003-607
 e-mail: mail@jumo.net
 Internet: www.jumo.net













JUMO Instrument Co. Ltd.
 JUMO House
 Temple Bank, Riverway
 Harlow, Essex CM 20 2TT, UK
 Phone: +44 1279 635533
 Fax: +44 1279 635262
 e-mail: sales@jumo.co.uk
 Internet: www.jumo.co.uk

JUMO Process Control, Inc.
 8 Technology Boulevard
 Canastota, NY 13032, USA
 Phone: 315-697-JUMO
 1-800-554-JUMO
 Fax: 315-697-5867
 e-mail: info@jumo.us
 Internet: www.jumo.us



Order details
MICROSTAT-M Type 608510

Order code

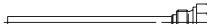
(6) Process connection (PA)¹		
750	TF 01; temperature probe with stepped support tube	
752	TF 11; temperature probe without support tube	
843	TA 02; immersion tube with union nut and loose nipple ²	
161	TA 03; immersion tube with loose union nut	
847	TA 06; sliding clamp fitting on support tube ²	
311	TA 20; immersion tube with loose nipple and shoulder ²	
872	TA 21; immersion tube with loose plug and conical seal	
873	TA 22; immersion tube with loose plug, conical seal and loose nipple ²	
401	TA 23; immersion tube with plug and spring clip	
913	SH 07; screw-in pocket, assembled, with clamping clip and fixing screw ²	
820	SH 09; weld-in pocket, assembled, with clamping clip and fixing screw (not with FL21 - welding shoulder with steel 1.4515)	
876	SH10; screw-in pocket, assembled ²	
871	SH11; screw-in pocket, assembled ²	
(7) Diameter of process connection (PA)¹		
6	6 mm dia.	
8	8 mm dia.	
10	10 mm dia.	
11	11 mm dia.	
12	12 mm dia.	
(8) Thread for process connection (PA)¹		
000	no thread (with TF 01 and TF 11)	
103	G ³ / ₈ thread	
104	G ¹ / ₂ thread	
105	G ³ / ₄ thread	
114	M 10 x 1 thread (with TA 23 and SH 11 only)	

JUMO GmbH & Co. KG
 Delivery address: Mackenrodtstraße 14,
 36039 Fulda, Germany
 Postal address: 36035 Fulda, Germany
 Phone: +49 661 6003-0
 Fax: +49 661 6003-607
 e-mail: mail@jumo.net
 Internet: www.jumo.net

JUMO Instrument Co. Ltd.
 JUMO House
 Temple Bank, Riverway
 Harlow, Essex CM 20 2TT, UK
 Phone: +44 1279 635533
 Fax: +44 1279 635262
 e-mail: sales@jumo.co.uk
 Internet: www.jumo.co.uk

JUMO Process Control, Inc.
 8 Technology Boulevard
 Canastota, NY 13032, USA
 Phone: 315-697-JUMO
 1-800-554-JUMO
 Fax: 315-697-5867
 e-mail: info@jumo.us
 Internet: www.jumo.us



Order details
MICROSTAT-M Type 608510

Order code

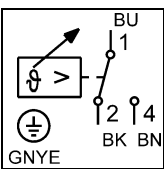
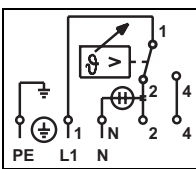
	(9) Material of probe / support tube¹
26	stainless steel (CrNi, 1.4571)
96	copper (Cu) / brass (CuZn) (up to 200°C)
95	stainless steel (CrNi, 1.4571) - probe / brass (CuZn) - support tube (from 250°C)
	(10) Material of process connection (PA)¹
00	none (TF01 and TF11 only)
01	steel (St)
26	stainless steel (CrNi, 1.4571)
46	brass (CuZn)
	(11) Fitting length of process connection (PA)¹ (dimension EL or S)
00	minimum fitting length TF 11 (active probe dimension)
50	50 mm
100	100 mm
150	150 mm
200	200 mm
...	special length (specify in plain text, in 50 mm steps)
	(12) Switching output (SA)
20	SA 20 one contact
	 
	Connection diagram, standard Connection diagram, with indicator light (TZ 572)
	(13) Extra codes (TZ)
000	no extra code
507	Electrical connection by screw terminals for cable up to 1.5 mm ² conductor cross-section
426	Plastic cover to protect the faston connectors or screw terminals against touching and splashing water, IP54 at rear, with cable gland, suitable for 6 – 8 mm cable dia.
650	Microswitch 10 (3) A (230 V AC/DC +10/-15%, 48 – 63 Hz, p.f. = 1 (0.6)) (not with TZ 577)
410	Metal bezel or flange, black
572	Indicator light (only with types: 608510/2572 TZ 460 and 608510/2596 TZ 460)
510	Stop for upper or lower limit of setpoint adjustment, factory-set
460	Housing centered for panel cut-out 68 x 68 mm and 92 x 92 mm (with basic type extensions 2572 and 2596 only)
315	Capillary reinforcement on housing and probe (not with FL21)
477	Setpoint adjustment protected by screw cap. Adjustment with screwdriver.
577	Protection against capillary break (not with TZ 650 and TZ 651)
522	Customized scale
489	Setpoint adjustment by 28 mm dia. setting device, with aluminium front disk; protected to IP54 at the front
651	Microswitch 3 (1) A (230 V AC/DC +10/-15%, 48 – 63 Hz, p.f. = 1 (0.6)) (not with TZ 577)

Special versions on request!

Order code

(1) 608510 / (2) - (3) ... - (4) .. - (5) - (6) ... - (7) .. - (8) ... - (9) .. - (10) .. - (11) ... - (12) .. / (13) ... , ...

Order example

608510 / 2160 - 818 - 21 - 2000 - 752 - 8 - 000 - 96 - 00 - 000 - 20 / 000³

¹ See Data Sheet 60.8730 for description and features.

² Screw-in spigot to DIN 3852 Form A.

³ List extra codes in sequence, separated by commas.