



Impedance converter for combination electrodes

Series 202995 (former designation: 2 AMZ-20)

- independent of mains supply
- retrofitting is possible
- enables longer cable distances
- stabilizes signal

Brief description

The impedance converter converts the high-impedance signal of a pH electrode (up to 1,000 MΩ) into a low-impedance signal (< 1 kΩ). The use of an impedance converter can also be advantageous in conjunction with a metal electrode. The impedance converter is screwed directly onto the electrode head. This largely eliminates interference caused by dirt, moisture or electrical fields from power cables. A conventional coaxial cable is sufficient as a connecting cable between impedance converter and transmitter. Long distances between sensor and transmitter can be covered easily. Thanks to its built-in lithium battery, the impedance converter does not depend on an external power supply.



Block diagram

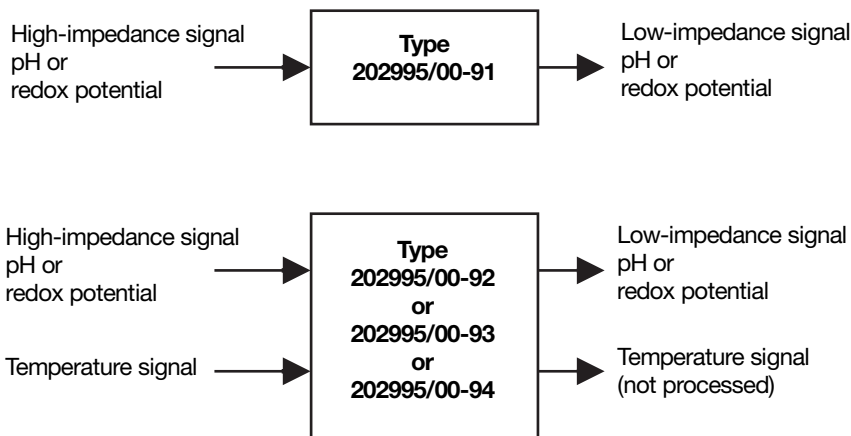

Technical data

Input

Input impedance	$R_e \geq 5 \times 10^{11} \Omega$
Input current	$i_e \leq 2 \text{ pA at } 25^\circ\text{C}$
Input voltage	$U_e \pm 1 \text{ V} \pm 10\%$

Output

Offset voltage	$U_0 \leq 6 \text{ mV (typ.)}$
Temperature drift	$15 \mu\text{V}/^\circ\text{C}$

Permissible ambient temperature
-10 to +60°C

Permissible storage temperature
-10 to +60°C

Internal impedance
 $R_i \leq 5 \Omega$

Amplification (pH or redox potential)
1 : 1

Linearity error
 $\leq 0.5\%$, if the input impedance of the subsequent amplifier is $\geq 20 \text{ M}\Omega$.

Supply

internally from lithium battery (can be replaced), CR-1/3N-P (or equivalent). Service life: at least 5 years (at 25°C). The life expectancy of the battery can be negatively affected by external factors, such as strongly fluctuating temperatures during operation or storage.

Housing

PC (polycarbonate)

Weight

35 g

Electrical connection

Input / output

The assignment of input and output is always identical

Connection

-91 (standard):

N cap

plug connector matches the JUMO electrode caps with cable socket N (see Data Sheet 20.2900) and most of the usual electrode caps (S7, S8).

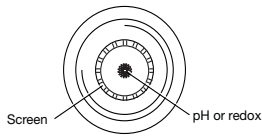

-92:

SMEK cap or SixPlug, terminal assignment "JUMO" for pH or redox combination electrodes with integrated temperature sensor (plan view of the connector for the impedance converter)

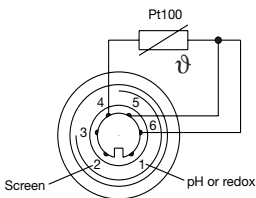

-93:

SMEK cap or SixPlug, terminal assignment "other electrode manufacturers" for pH or redox combination electrodes with integrated temperature sensor (plan view of the connector for the impedance converter)

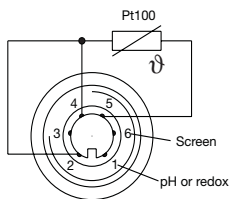

(1) Connection to glass/metal electrode

(2) Connection to reference electrode

-94:

SMEK cap or SixPlug, terminal assignment for multiparameter sensor (pH/redox and temperature signal) e.g. JUMO Multitrode (plan view of the connector for the impedance converter)

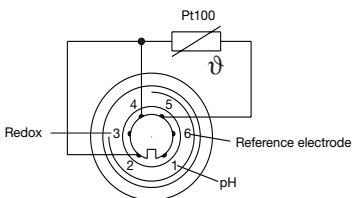

Dimensions

Type 202995/00-91

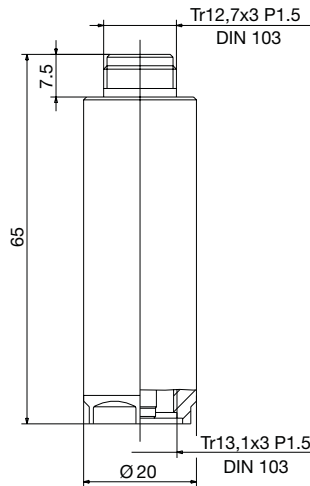

Type 202995/00-92

Type 202995/00-93

Type 202995/00-94

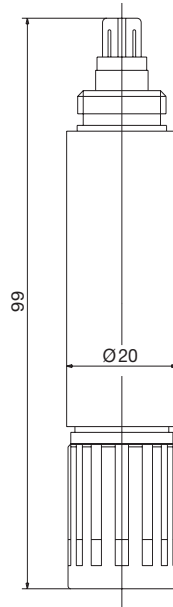

Available from stock

(delivery 3 days after receipt of order)

Impedance converter with N cap, Type 202995/00-91

Sales No.

20/00300455

Not available from stock

(delivery 2 weeks after receipt of order)

Impedance converter with SMEK cap (SixPlug), pin assignment "JUMO"¹, Type 202995/00-92

Sales No.

20/00406964

Impedance converter with SMEK cap (SixPlug), pin assignment "other electrode manufacturers"¹, Type 202995/00-93

Sales No.

20/00406965

¹ Take note of the pin assignment!

Order details

(1) Basic type

202995 Impedance converter

(2) Basic type extension

00 none

(3) Connection

91 N cap, matching the N connector

92 SMEK cap (SixPlug), pin assignment JUMO¹

93 SMEK cap (SixPlug), pin assignment "other electrode manufacturers"¹

94 SMEK cap (SixPlug), for multiparameter sensor (pH, redox, temperature)¹

Order code

(1)	(2)	(3)
202995	/ 00	-

Order example

202995	/ 00	-	91
--------	------	---	----