

JUMO GmbH & Co. KG
Delivery address: Mackenrodtstraße 14,
36039 Fulda, Germany
Postal address: 36035 Fulda, Germany
Phone: +49 661 6003-0
Fax: +49 661 6003-607
e-mail: mail@jumo.net
Internet: www.jumo.net

JUMO Instrument Co. Ltd.
JUMO House
Temple Bank, Riverway
Harlow, Essex CM 20 2TT, UK
Phone: +44 1279 635533
Fax: +44 1279 635262
e-mail: sales@jumo.co.uk
Internet: www.jumo.co.uk

JUMO Process Control, Inc.
8 Technology Boulevard
Canastota, NY 13032, USA
Phone: 315-697-JUMO
1-800-554-JUMO
Fax: 315-697-5867
e-mail: info@jumo.us
Internet: www.jumo.us



JUMO dTRANS O2 01 Two-wire Transmitter for dissolved oxygen (DO)

with optional terminal box or operating unit

Type 202610

Brief description

The JUMO dTRANS O2 01 two-wire transmitter is used for the measurement of dissolved oxygen in aqueous solutions. It provides an electrically isolated 4 – 20 mA output signal corresponding to the oxygen content. The instrument can be configured through a setup program or from a terminal box / operating unit (available as an option). The temperature of the medium can be acquired through a Pt1000 in the two-wire transmitter and further processed (from the standard version and above, also as 4 – 20 mA two-wire signal).

The measurement is made with an electrochemical, membrane-covered sensor. The microprocessor circuit incorporated in the two-wire transmitter takes account of the temperature, atmospheric pressure and salinity (salt content) factors. The sensor is of modular design and is easy to maintain and replace.

Typical areas of application

- Municipal and industrial sewage-treatment plants
- Drinking water monitoring
- Prevention of water pollution
- Fish farming (fresh and salt water)
- Processing plants

Versions and delivery package

Basic version

- Two-wire transmitter
JUMO dTRANS O2 01
- 8 m attached cable
- Terminal box (IP65) with button for calibration

The basic version is designed for direct connection to a PLC or a recording instrument. The calibration function can be initiated locally. The transmitter can be configured through the setup program (available as an option).

The supply to the two-wire transmitter is provided by a separate power supply (optional), e.g. JUMO TN-22, see Data Sheet 95.6024.

The JUMO dTRANS Az 01 (Data Sheet 20.2550), with bezel size 96 x 48mm, is a suitable indicator/controller for the basic version. This instrument is recommended where there is no requirement for a direct connection to a PLC or recording instrument.

The JUMO dTRANS Az 01 can also provide the supply required for the two-wire transmitter.

Standard version

As for the basic version, but with an operating unit (instead of the terminal box) that has a display and additional operating keys. The supply for the two-wire transmitter and the operating section is provided by an (optional) separate power supply, e.g. JUMO TN-22, see Data Sheet 95.6024. An additional power supply (e.g. JUMO TN-22) is required for the optional two-wire transmitter for temperature.

The instrument is operated from the membrane keypad. Operator guidance in plain text ensures that operation is easy to understand. The dTRANS O2 01 is configured via the operating unit.

Maximum version

As for the standard version. In addition, the operating unit has its own power supply for the oxygen and temperature two-wire transmitters, a signal output (4 – 20 mA) for temperature, and two freely programmable relays for alarm functions and limit control. This version features a backlit display.

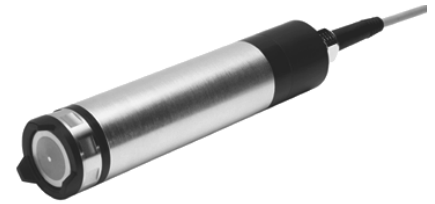

Two-wire transmitter
JUMO dTRANS O2 01



Optional operating unit

Key features

- Measurement of dissolved oxygen (DO) in aqueous solutions
- Safe single-point calibration
- Two-wire transmitter (with basic and standard versions)
- Electrical isolation of measurement signal (DO) and output signal (mA)
- Problem-free linking to an existing installation (e.g. PLC)
- The full (maximum) version provides a stand-alone solution
- Compensation of temperature, atmospheric pressure and salinity
- Further processing of the temperature of the medium possible (separate Pt1000 and two-wire transmitter)
- Setup program provides convenient transmitter configuration/documentation
- Simpler, safer servicing by replacing modules
- Backlit display, i.e. easy to read even in darkness (for the maximum version)
- Comprehensive range of accessories

Accessories available

- Setup software
- PC interface cable
- Replacement sensor modules (set)
- Fittings

Technical data

General

Supply

Basic version Type 202610/80 and Standard version Type 202610/81
19 – 31 V DC; nominal 24 V DC

Maximum version Type 202610/82
110 – 240 V AC +10%/-15%, 48 – 63Hz
or 20 – 30 V AC/DC, 48 – 63Hz

Power drawn: approx. 8 VA

Permissible ambient temperature

-5 to +50°C

Cable length

between oxygen transmitter and indicator/operating unit
8 m

Electrical connection

pluggable screw terminals

Lightning protection

coarse and fine protection

Electromagnetic compatibility (EMC)

to EN 61326

Oxygen transmitter

Range

0 – 2 to 0 – 50 mg/l
(freely programmable)

Measurement units

mg/l or % saturation

Accuracy

±1% of end of range (20 mg/l)

Temperature compensation

0 to +50°C

Atmospheric pressure compensation

direct via atmospheric pressure:
500 – 1500 hPa (mbar) or

indirect via height a.m.s.l.:

0 – 3000 m

Salinity (salt content compensation)

0 – 40 g/kg

Output signal

4 – 20 mA, freely scalable within the range

Response time (at 25°C)

$t_{90} < 180$ sec

Minimum inflow

5 cm/sec

Safe pressure

6 bar max. at 20°C

Pressure variations will affect the output signal!

Protection

IP68 to EN 60529

Housing material

shaft: stainless steel 1.4305

sensor head and

protective basket: PVC

Weight

approx. 700 g

Terminal box and operating unit

Protection

IP65 to EN 60529

Housing material

PC

Weight

approx. 2 kg

Burden

Basic version Type 202610/80

Output dissolved oxygen:

$$\leq \frac{U_B - 10 \text{ V}}{0.02 \text{ A}}$$

Standard version Type 202610/81:

Output dissolved oxygen / temperature

$$\leq \frac{U_B - 17 \text{ V}}{0.02 \text{ A}}$$

Maximum version Type 202610/82

Output dissolved oxygen / temperature:

≤ 500 Ω

Display resolution

0.01 mg/l and 0.1%;

0.1 °C

Temperature measurement

Range

0 – 50°C (fixed)

Accuracy

Basic version

Type 202610/80-500-2000-08-28

Sensor: Pt1000, Class B

Display: n/a

Output signal: n/a

Standard version

Type 202610/81-500-2000-08-28

Sensor: Pt1000, Class B

Display: 0.25% of range

Output signal: n/a

Standard version

Type 202610/81-405-2000-08-28

Display: 0.25% of range

Output signal: 1% of range

Maximum version

Type 202610/82-006-2000-08-23

Display: 0.25% of range

Output signal: 1% of range

Electrical connection

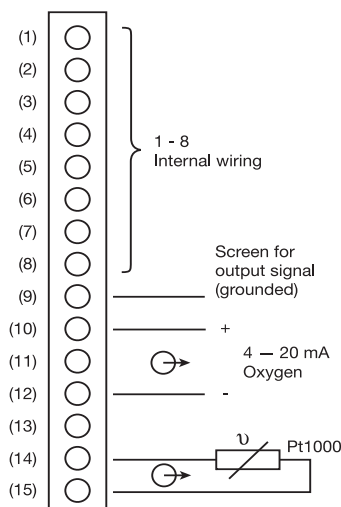

Type 202610/80-500-2000-08-28
Type 202610/81-500-2000-08-28

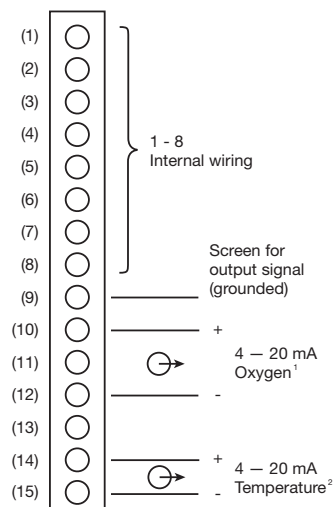

Type 202610/81-405-2000-08-28

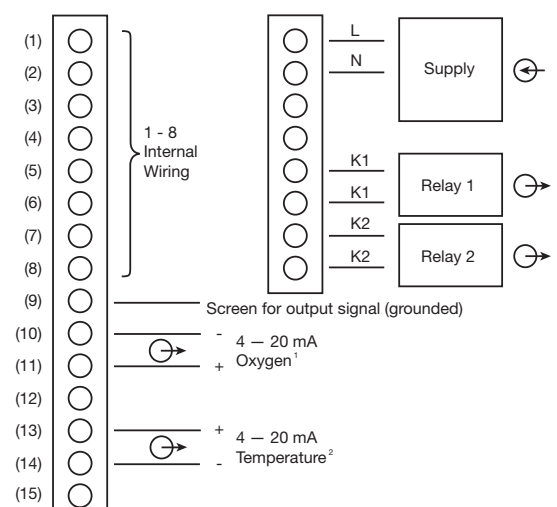

Type 202610/82-006-2000-08-23
Type 202610/82-006-2000-08-25

¹ freely scalable

² fixed setting: 10 to 50°C corresponding to 4 - 20 mA

Dimensions

Oxygen transmitter

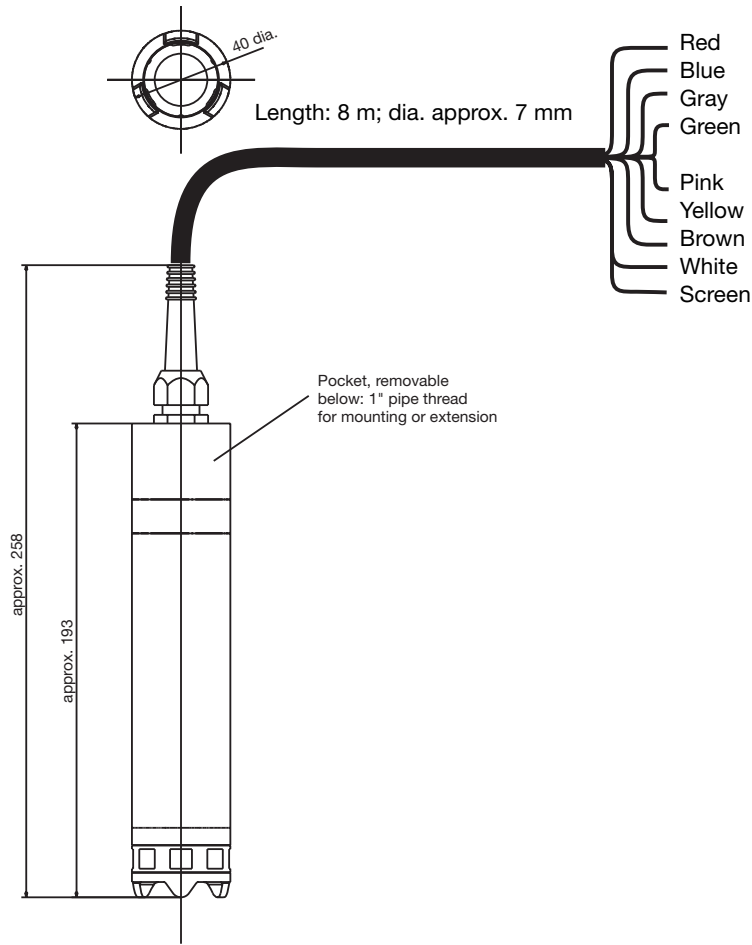

- Red
- Blue
- Gray
- Green
- Pink
- Yellow
- Brown
- White
- Screen

Color	Terminal in box	Signal
Pink	1	RXD
Green	2	GND
Yellow	3	TXD
White	4	b Pt1000
Brown	5	a Pt1000
Red	6	+e / -l
Blue	7	-e / +l
Screen	8	
Gray	11	CAL / NC

Terminal box or operating unit

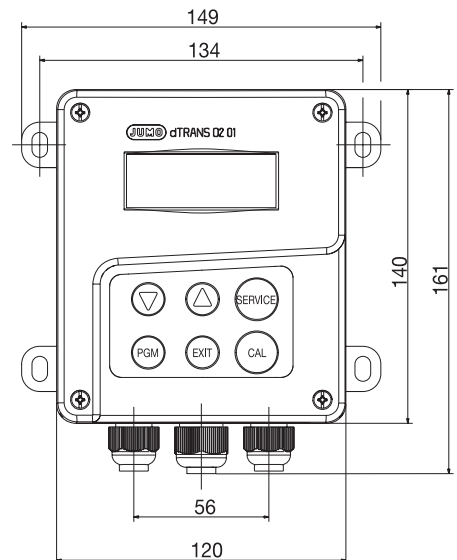
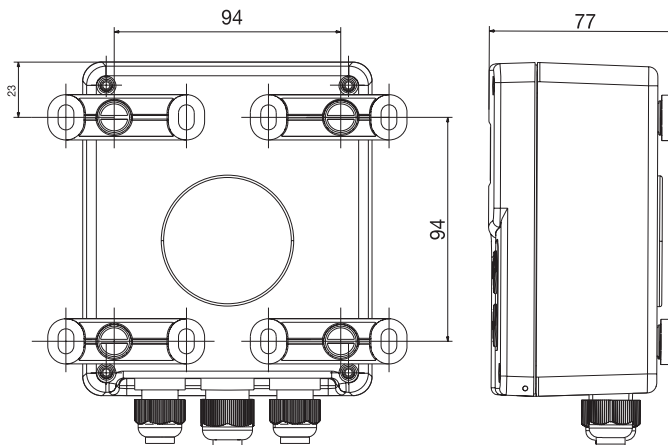
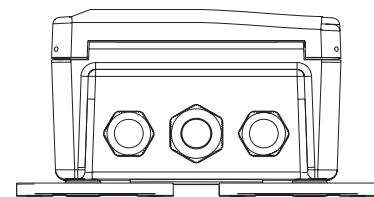
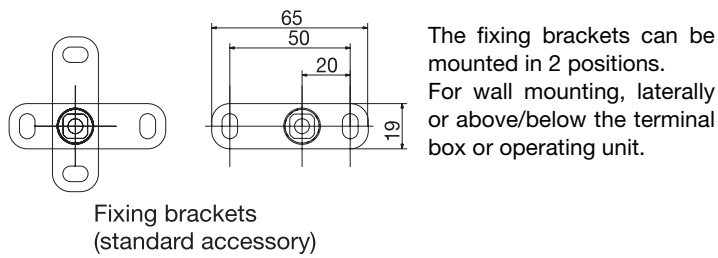

Connection examples

Basic version 202610/80-500-2000-08-28 with terminal box

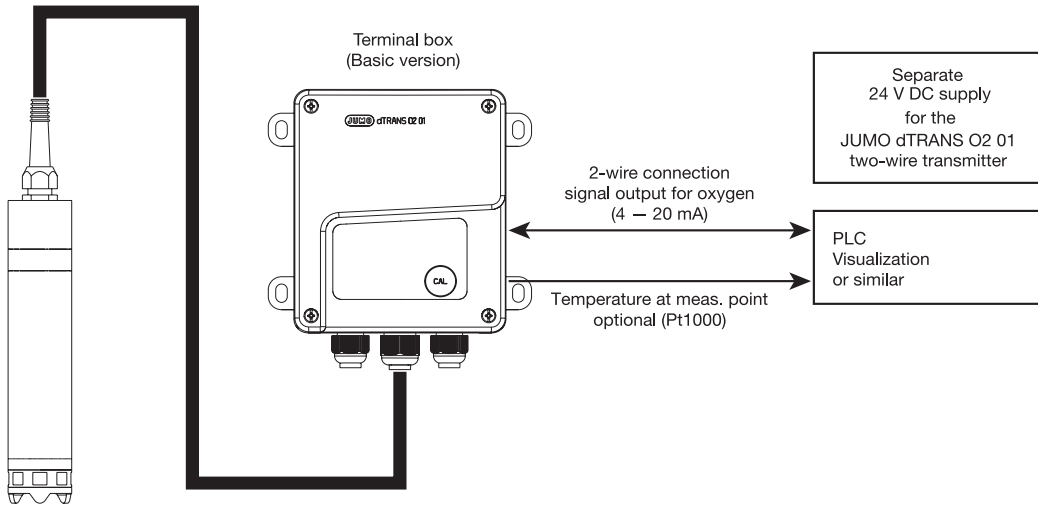

Two-wire transmitter for dissolved oxygen (DO)

Basic version 202610/80-500-2000-08-28 with terminal box and JUMO dTRANS Az 01

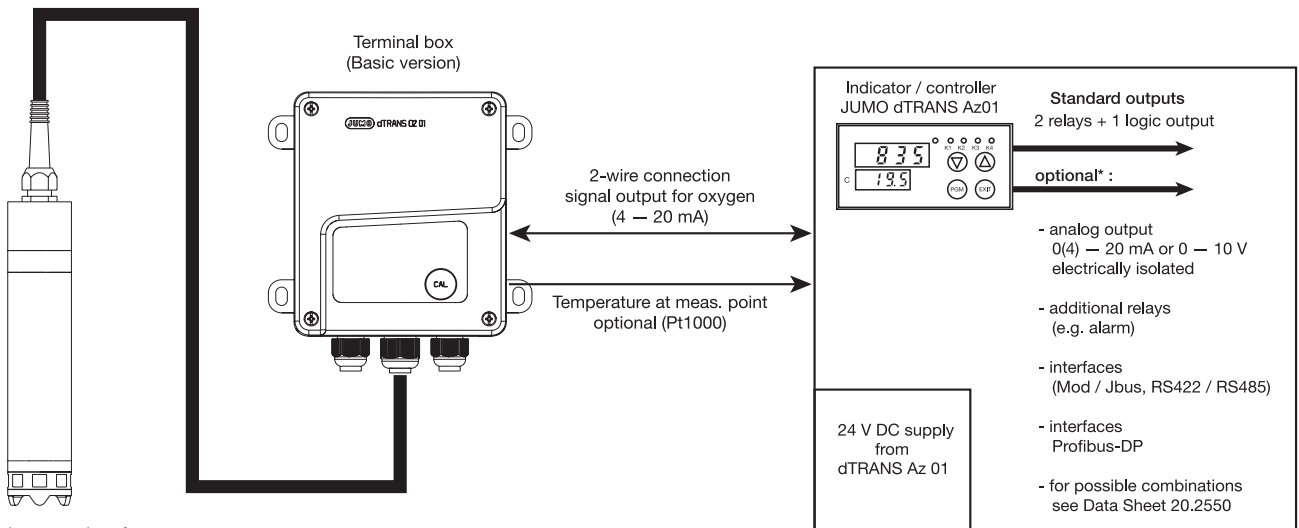

Two-wire transmitter for dissolved oxygen (DO)

Standard version 202610/81-405-2000-08-28 with operating unit

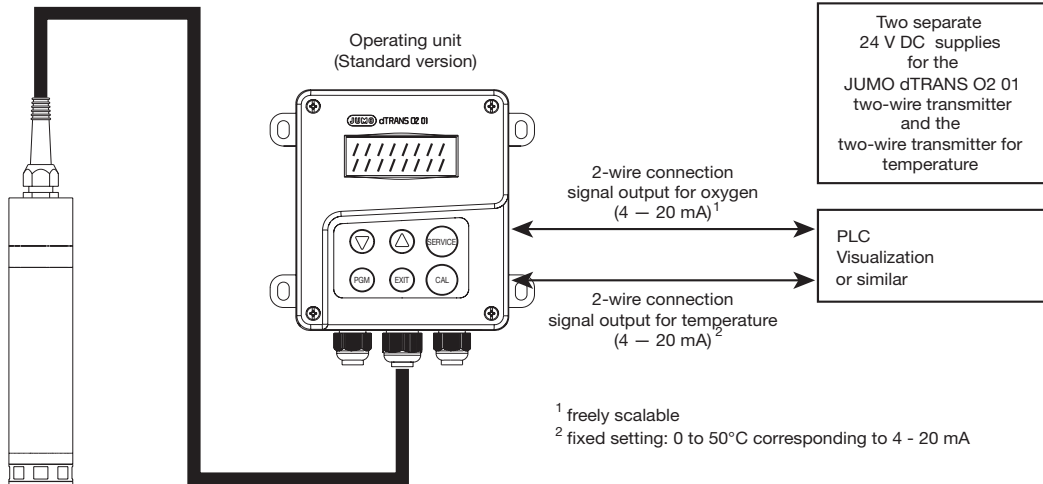

2-wire transmitter for dissolved oxygen (DO)

Maximum version 202610/82-006-2000-08-23 with operating unit

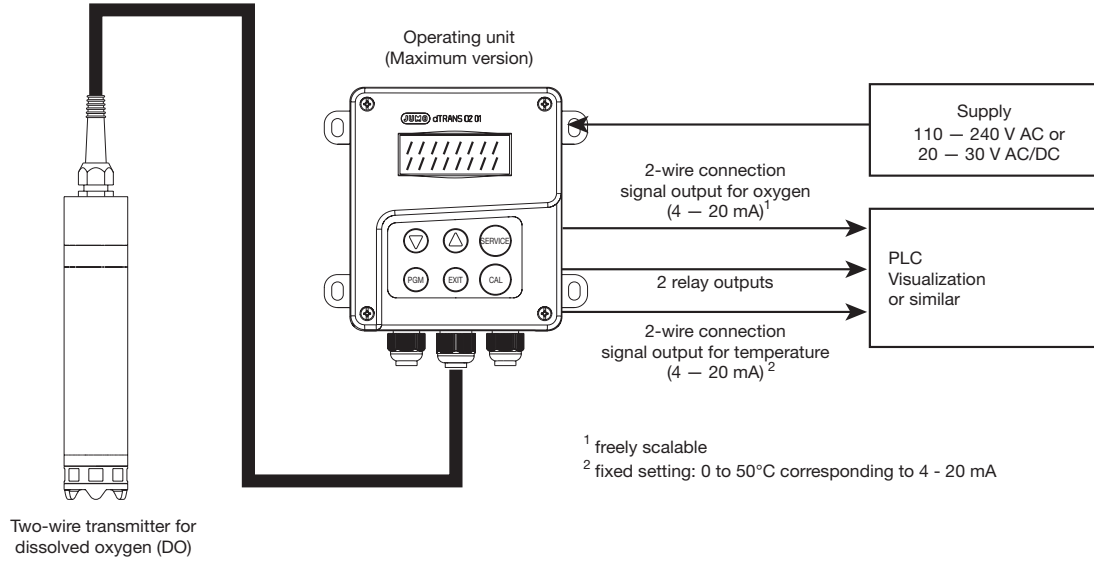

Accessories

Flow-through fittings

Brief description

The dTRANS O2 01 oxygen transmitter can be mounted in flow-through fittings. The fittings are installed directly in the pipeline conveying the medium, or in the bypass. The special construction of the fitting ensures a correct flow into the sensors, and therefore avoids measurement errors.

The following points should be noted when planning the pipework layout:

- The fitting must be readily accessible, to allow regular maintenance and cleaning of the transmitter or the fitting itself.
- Bypass measurements are recommended. Shut-off valves should be provided so that the transmitter can be removed.
- Where systems are subject to temperature or pressure stresses, the fitting and transmitter must meet the requirements.
- The suitability of the materials of the fitting and the transmitter (e.g. chemical compatibility) must be checked by the system designer.

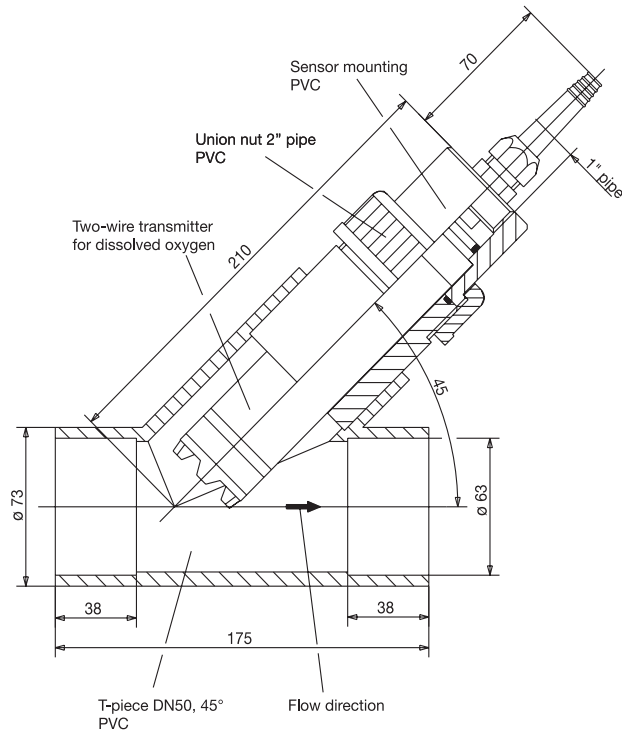

Flow-through fitting, angled seat	
Material	PVC
Permissible temperature	+5 to +50°C
Safe pressure	up to 1 bar
Connection	solvent weld sockets
Process connection	T-piece DN50, 45°
Sales No.	20/00398137

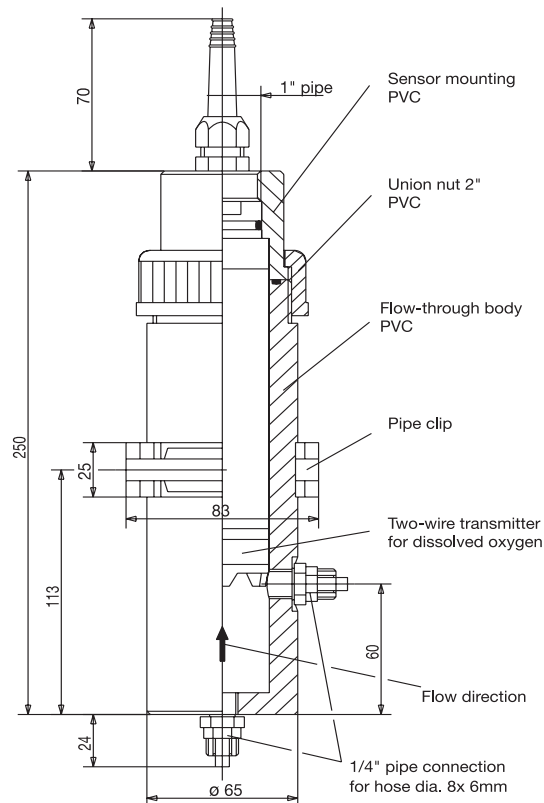

Flow-through fitting, hose connection	
Material	housing PVC pipe clip PP
Permissible temperature	+5 to +50°C
Safe pressure	up to 1 bar
Connection	solvent weld sockets
Process connection	1/4" pipe (for hose 8 x 6 mm dia.)
Sales No.	20/00398142

Immersion fittings

Brief description

The dTRANS O2 01 oxygen transmitter can be mounted in immersion fittings. The fittings are installed in open containers or sluices using the pipe clips supplied. Different immersion depths are facilitated by various immersion lengths.

The following points should be noted at the design stage:

- The fitting must be readily accessible, to allow regular maintenance and cleaning of the transmitter or the fitting itself.
- The suitability of the materials of the fitting and the transmitter (e.g. chemical compatibility) must be checked by the system designer.

Immersion fitting	
Material	immersion tube PVC pipe clip PP
Permissible temperature	+5 to +50°C
Safe pressure	up to 1 bar
Cable gland	Pg11
Protection	IP65 EN 60 529
Immersion length	500 mm
Sales No.	20/00398131
Immersion length	1500 mm
Sales No.	20/00398135

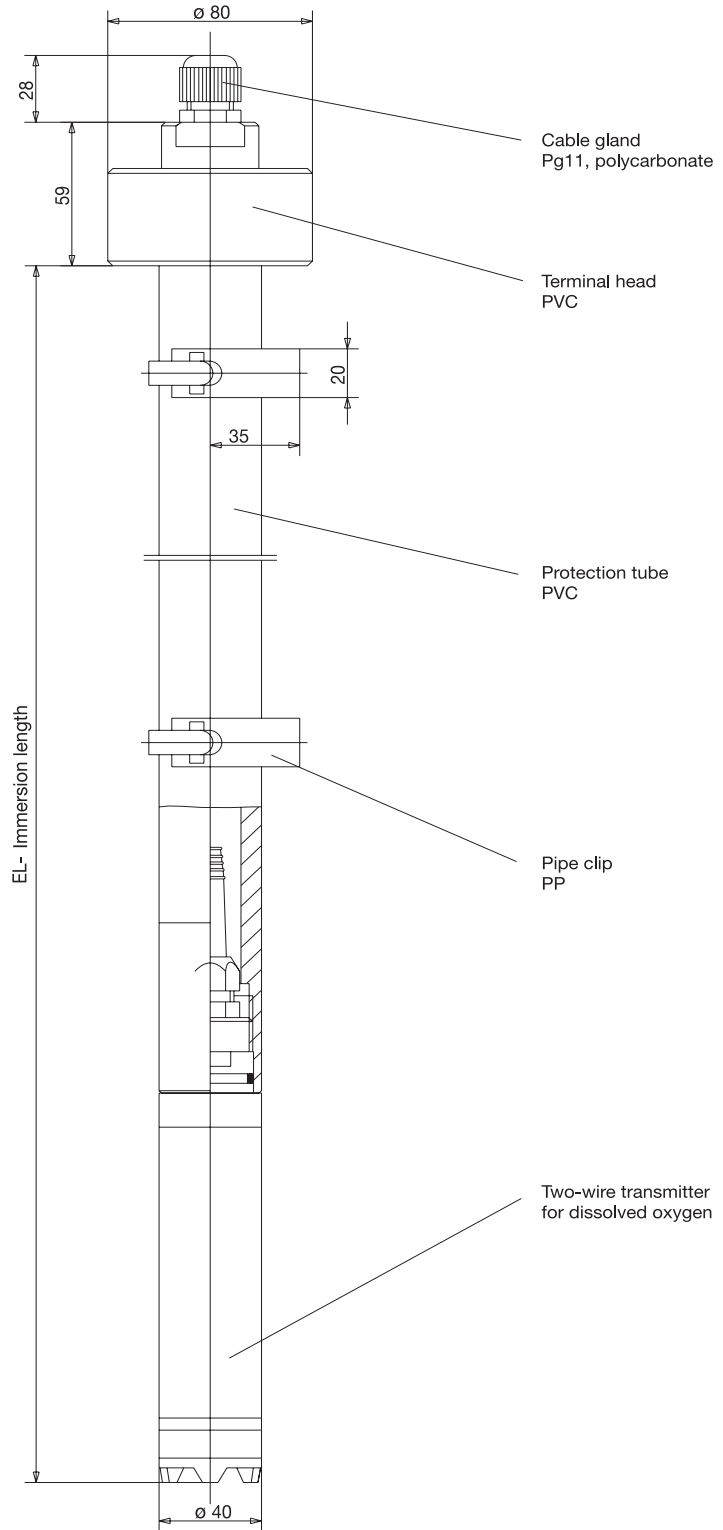

Suspension fittings

Brief description

The dTRANS O2 01 oxygen transmitter can be mounted in suspension fittings. The fittings are used primarily for measurement in open vessels. The fitting can be positioned far from the edge of the vessel, suspended from a chain by the shackle, for example. Different immersion depths are facilitated by various immersion tube lengths.

The following points should be noted at the design stage:

- The fitting must be readily accessible, to allow regular maintenance and cleaning of the transmitter or the fitting itself.
- The fitting (and with it the transmitter) must not strike the side of the vessel as a result of pendular movements.
- The suitability of the materials of the fitting and the transmitter (e.g. chemical compatibility) must be checked by the system designer.

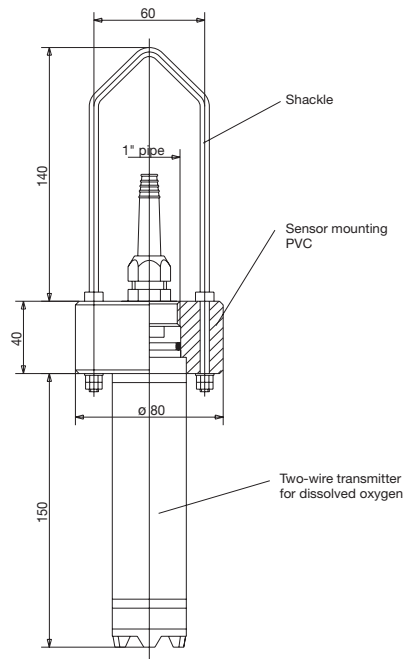

Suspension fitting	
Material	immersion tube PVC shackle stainless steel
Permissible temperature	+5 to +50°C
Safe pressure	up to 1 bar
Cable gland	Pg11
Protection	IP65 EN 60 529
Immersion length	150 mm
Sales No.	20/00398148
Immersion length	500 mm
Sales No.	20/00398143
Immersion length	1500 mm
Sales No.	20/00398144

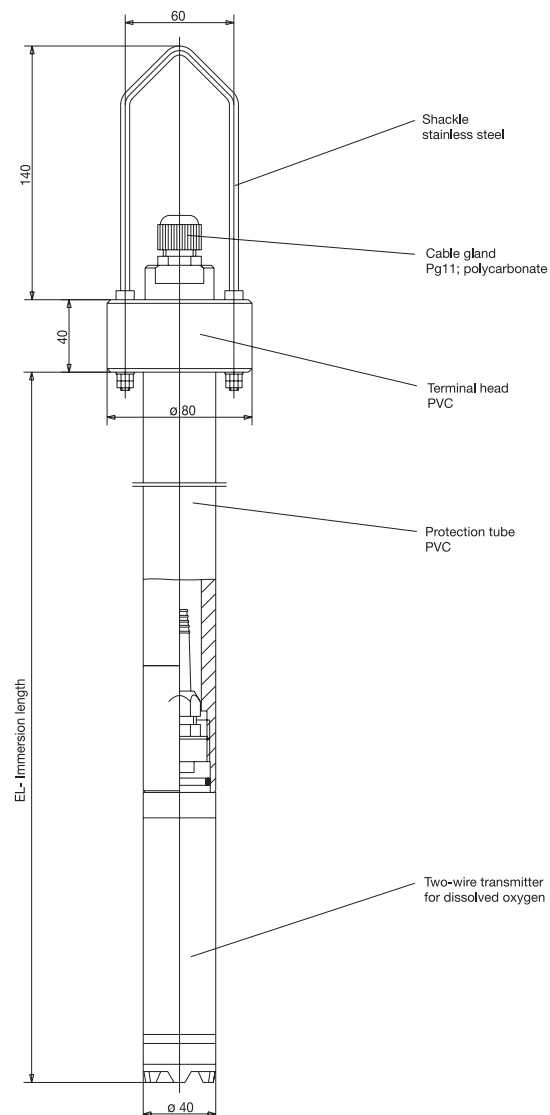

Float fittings

Brief description

Float fittings are used to mount an immersion fitting in which a dTRANS O2 01 oxygen transmitter is installed. The fittings are used primarily for measurement in open vessels or watercourses. Different immersion depths are facilitated by various support tube lengths of the immersion fitting.

The following points should be noted at the design stage:

- The fitting must be readily accessible, to allow regular maintenance and cleaning of the transmitter or the fitting itself.
- Where the depth of water fluctuates, it must be ensured that the fitting (and with it the transmitter) does not strike the base of the vessel or the watercourse when the water level is low.
- The suitability of the materials of the fitting and the transmitter (e.g. chemical compatibility) must be checked by the system designer.

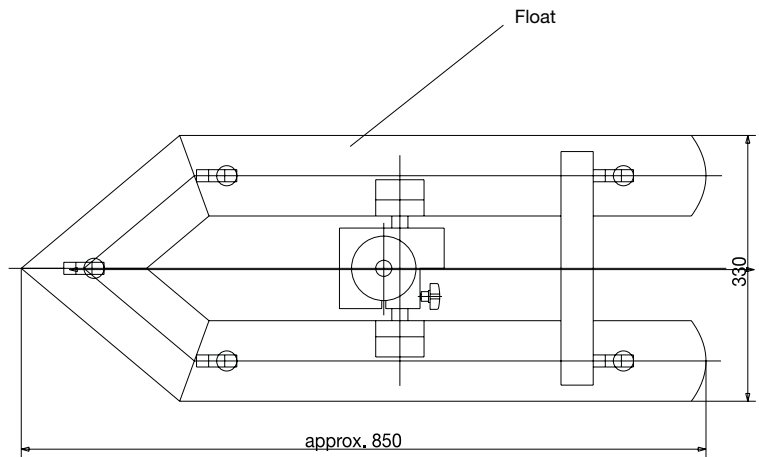
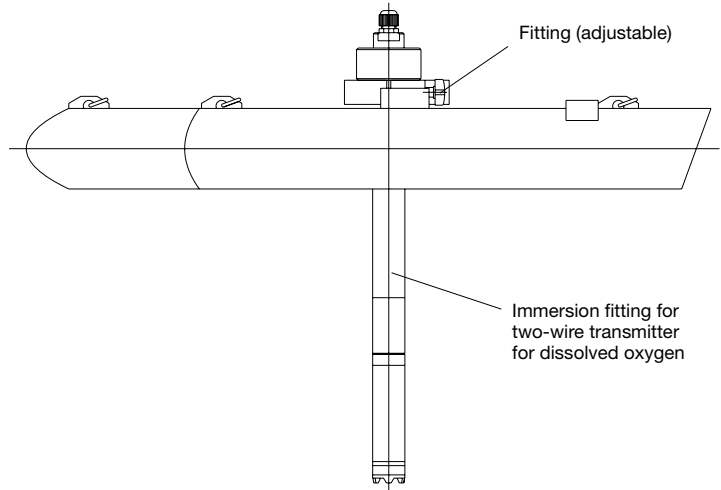

Float fitting	
Material	PVC
Permissible temperature	+5 to +50°C
Fitting mounting	40 mm
Sales No.	20/00397483

Suitable immersion fitting	
Immersion length	500 mm
Sales No.	20/00398131
Immersion length	1500 mm
Sales No.	20/00398135

Support column with pedestal base, arm, chain and weather protection canopy

Brief description

This accessory is intended for installation at the edge of a vessel. The dTRANS O2 01 oxygen transmitter is installed in a suspension fitting. Different immersion depths and distances from the edge of the vessel are facilitated by the arm and the chain.

The weather protection canopy protects the terminal box or operating unit against the effects of the weather.

The following points should be noted at the design stage:

- The fitting must be readily accessible, to allow regular maintenance and cleaning of the transmitter or the fitting itself.
- The fitting (and with it the transmitter) must not strike the side of the vessel as a result of pendular movements.
- The suitability of the materials of the fitting and the transmitter (e.g. chemical compatibility) must be checked by the system designer.

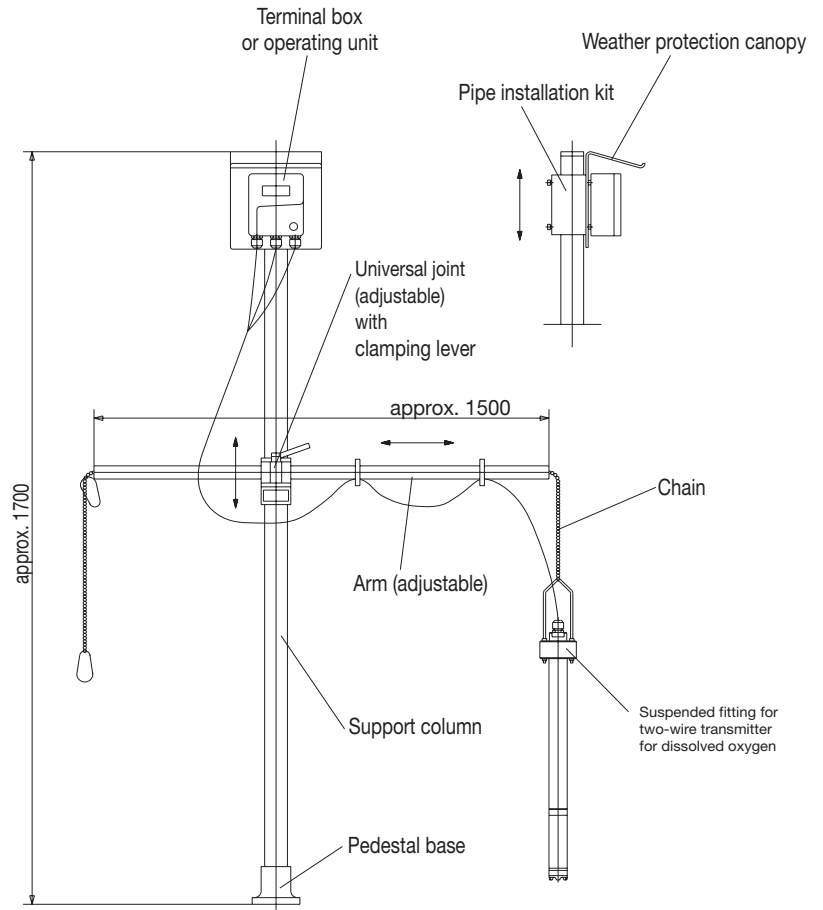

Support column with pedestal base, arm, chain	
Material	
Column	stainless steel
Pedestal base	die-cast aluminum
Arm	stainless steel
Chain	stainless steel
Universal joint	die-cast aluminum
Permissible temperature	-5 to +50°C
Sales No.	20/00398163

Pipe installation kit ¹	
Material	stainless steel
Sales No.	20/00398162

Weather protection canopy ²	
Material	stainless steel
Sales No.	20/00398161

Suspension fitting	
Material	see above
Sales No.	20/00398143 or 20/00398144

¹ Using the pipe installation kit, the terminal box or the operating unit can be attached to a pipe (e.g. support column or railing).

² The pipe installation kit is required for mounting the weather protection canopy

Order details

(1) Basic type
 202610 Two-wire transmitter for dissolved oxygen (DO)

(2) Basic type extensions

	80	Basic version ¹
	81	Standard version ¹
	82	Maximum version ¹
		(3) Output (of additional temperature output)
X	006	4 – 20 mA (internal supply)
X	405	4 – 20 mA (external supply)
X X	500	Resistance output Pt1000
		(4) Range for oxygen
X X X	2000	0 – 20 mg/l (programmable)
		(5) Cable length
X X X	08	8 m
		(6) Supply
	X 23	110 – 240 V AC +10% / -15%, 48 – 63 Hz
	X 25	20 – 53 V AC/DC, 48 – 63 Hz
X X	28	19 – 31 V DC (2-wire transmitter)
		(7) Language
X X	1	German (standard)
X X	2	English
X X	3	French
X X	4	Spanish

X = combination is possible

	(1)	(2)	(3)	(4)	(5)	(6)	(7)
Order code	202610	/ ..	-	2000	-	08	-
Order example	202610	/ 81	-	500	-	2000	-

¹ Special version: if significant contamination is to be expected, the protective basket of the oxygen transmitter can be delivered equipped with a protective membrane. However, this membrane will delay the sensor response.

Note:

The type code is a type designation, not a modular system.

If at all possible, please choose the items listed under “Available ex-stock” or “Not available ex-stock” when ordering.

Any free combination of individual code features must be technically checked by us and released.

Please ask us in case of doubt !

Available ex-stock

Type	Sales No.
202610/80-500-2000-08-28-1 (operator language: German)	20/00391336
202610/81-405-2000-08-28-1 (operator language: German)	20/00391357
202610/82-006-2000-08-23-1 (operator language: German)	20/00391358

Not available ex-stock

Type	Sales No.
202610/82-006-2000-08-25-1 (operator language: German)	20/00393328
202610/82-006-2000-08-23-2 (operator language: English)	20/00406637
202610/82-006-2000-08-28-2 (operator language: English)	20/00409019
202610/82-006-2000-15-23-2 (operator language: English)	20/00427326
202610/80-500-2000-08-28-3 (operator language: French)	20/00439521
202610/81-405-2000-08-28-3 (operator language: French)	20/00439522
202610/82-006-2000-08-23-3 (operator language: French)	20/00439523
202610/81-405-2000-08-28-4 (operator language: Spanish)	20/00437029
202610/82-006-2000-08-23-4 (operator language: Spanish)	20/00436038

Optional accessories available ex-stock

Description	Sales No.
Flow-through fitting, angled seat	20/00398137
Flow-through fitting, hose connection	20/00398142
Immersion fitting, immersion tube length 500 mm	20/00398131
Immersion fitting, immersion tube length 1500 mm	20/00398135
Suspension fitting, immersion tube length 150 mm	20/00398148
Suspension fitting, immersion tube length 500 mm	20/00398143
Suspension fitting, immersion tube length 1500 mm	20/00398144
Float fitting	20/00397483
Support column with pedestal base, arm and chain	20/00398163
Weather protection canopy for terminal box or operating unit ³	20/00398161
Pipe installation kit for terminal box or operating unit ⁴	20/00398162
Set of replacement sensor modules (2 items + Operating Instructions)	20/00393329
Setup program with adapter for dTRANS O2 01	20/00394728
PC interface cable with TTL / RS232 converter	95/00301315

³ The pipe installation kit is necessary for mounting the weather protection canopy.

⁴ The pipe installation kit can be used to fix the terminal box or the operating unit to a pipe (e.g. support column or railing).