

INSTRUCTION MANUAL

SIL 3 - SIL 2 IIB Group Power Supply
for Hazardous Area Equipment
DIN-Rail Model PSD1001C

SIL Applications

For Safety Related System and SIL2, SIL3 Applications according IEC61508 & IEC61511 Standards refer to "Functional Safety Manual" document number ISM0071

Characteristics

General Description: The PSD1001C is a single channel DIN Rail Power Supply to drive measuring, process control equipments in IIB Group Hazardous Area; it provides isolation between input and output. Typical applications is to drive high power devices, transmitters or other equipments with 13.5 V, 100 mA supply capability.

Function: 1 channel I.S. IIB Group power supply to operate Hazardous Area loads providing isolation (input/output).

Signalling LED: Power supply indication (green).

EMC: Fully compliant with CE marking applicable requirements.

Technical Data

Supply: 24 Vdc nom (21.5 to 30 Vdc) reverse polarity protected, ripple within voltage limits ≤ 5 Vpp.

Current consumption @ 24 V: 110 mA with 80 mA nominal load, 130 mA with 100 mA load and 150 mA with short circuit output.

Power dissipation: 1.8 W with 24 V supply voltage and 100 mA nominal load.

Max. power consumption: at 30 V supply voltage and short circuit output, 3.9 W.

Isolation (Test Voltage): I.S. Out/Supply 1.5 KV.

Output: 100 mA at 13.5 V (20.5 V no load, 68.3 Ω series resistance).

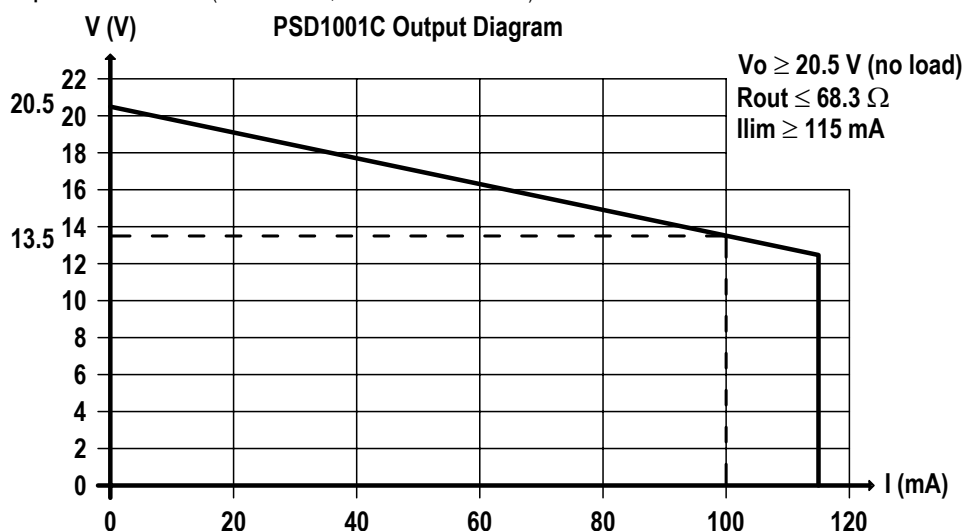

Short circuit current: ≥ 115 mA.

Compatibility:

CE CE mark compliant, conforms to 94/9/EC Atex Directive and to 2004/108/CE EMC Directive.

Environmental conditions: Operating: temperature limits -20 to +60 $^{\circ}$ C, relative humidity max 90 % non condensing, up to 35 $^{\circ}$ C.

Storage: temperature limits -45 to +80 $^{\circ}$ C.

Safety Description:



II (1) G [Ex ia Ga] IIB, II (1) D [Ex ia Da] IIIC, I (M1) [Ex ia Ma] I, II 3G Ex nA II [IIB] T4, [Ex ia Ga] IIB, [Ex ia Da] IIIC, [Ex ia Ma] I associated electrical apparatus.

Uo/Voc = 23.6 V, Io/Isc = 352.8 mA, Po/Po = 1674 mW at terminals 13/15-14/16.

Um = 250 Vrms, -20 $^{\circ}$ C \leq Ta \leq 60 $^{\circ}$ C.

Approvals: DMT 01 ATEX E 042 X conforms to EN60079-0, EN60079-11, EN60079-26, EN61241-0, EN61241-11,

IECEx BVS 07.0027X conforms to IEC60079-0, IEC60079-11, IEC60079-26, IEC61241-0, IEC61241-11, IMQ 09 ATEX 013 X conforms to EN60079-0, EN60079-15,

UL & C-UL E222308 conforms to UL913 (Div.1), UL 60079-0 (General, All Zones), UL60079-11 (Intrinsic Safety "i" Zones 0 & 1), UL60079-15 ("n" Zone 2), UL 1604 (Div.2) for UL and

CSA-C22.2 No.157-92 (Div.1), CSA-E60079-0 (General, All Zones), CSA-E60079-11 (Intrinsic Safety "i" Zones 0 & 1), CSA-C22.2 No. 213-M1987 (Div. 2) and

CSA-E60079-15 ("n" Zone 2) for C-UL, refer to control drawing ISM0145 for complete UL and C-UL safety and installation instructions,

FM & FM-C No. 3024643, 3029921C, conforms to Class 3600, 3610, 3611, 3810 and C22.2 No.142, C22.2 No.157, C22.2 No.213, E60079-0, E60079-11, E60079-15,

Russia according to GOST 12.2.007.0-75, R 51330.0-99, R 51330.10-99 [Exia] IIB X, Ukraine according to GOST 12.2.007.0,22782.0,22782.5 Exia IIB X,

EXIDA Report No. GM04/10-26 R002, SIL 2 / SIL 3 according to IEC 61508, IEC 61511. Please refer to Functional Safety Manual for SIL applications.

DNV and KR Type Approval Certificate for marine applications.

Mounting: T35 DIN Rail according to EN50022.

Weight: about 110 g.

Connection: by polarized plug-in disconnect screw terminal blocks to accommodate terminations up to 2.5 mm².

Location: Safe Area/Non Hazardous Locations or Zone 2, Group IIC T4, Class I, Division 2, Groups A, B, C, D Temperature Code T4 and Class I, Zone 2, Group IIC, IIB, IIA T4 installation.

Protection class: IP 20.

Dimensions: Width 22.5 mm, Depth 99 mm, Height 114.5 mm.

Ordering information:

Model:	PSD1001C
Power Bus enclosure	/B

Front Panel and Features

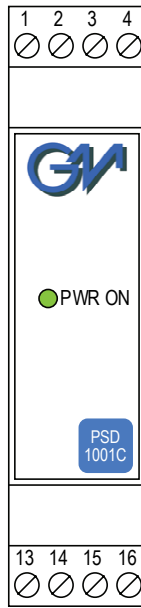

- SIL 3 according to IEC 61508, IEC 61511 in Loop Powered mode for Lifetime = 10 years.
- SIL 2 according to IEC 61508, IEC 61511 in Bus Powered mode for Tproof = 2 / 5 years (10 / 20 % of total SIF).
- PFDavg (1 year) 0.00 E-00, SFF 100 % (Loop Powered mode).
- PFDavg (1 year) 3.64 E-04, SFF 80.12 % (Bus Powered mode).
- Output to Zone 0 (Zone 20), Division 1, installation in Zone 2, Division 2.
- High output capability Power Supply for Hazardous Area equipment.
- Output short circuit proof and current limited.
- Isolation Input/Output.
- EMC Compatibility to EN61000-6-2, EN61000-6-4.
- ATEX, IECEx, UL & C-UL, FM & FM-C, Russian and Ukrainian Certifications.
- Type Approval Certificate DNV and KR for marine applications.
- High Reliability, SMD components.
- Simplified installation using standard DIN Rail and plug-in terminal blocks.
- 250 Vrms (Um) max. voltage allowed to the instruments associated with the barrier.

Terminal block connections

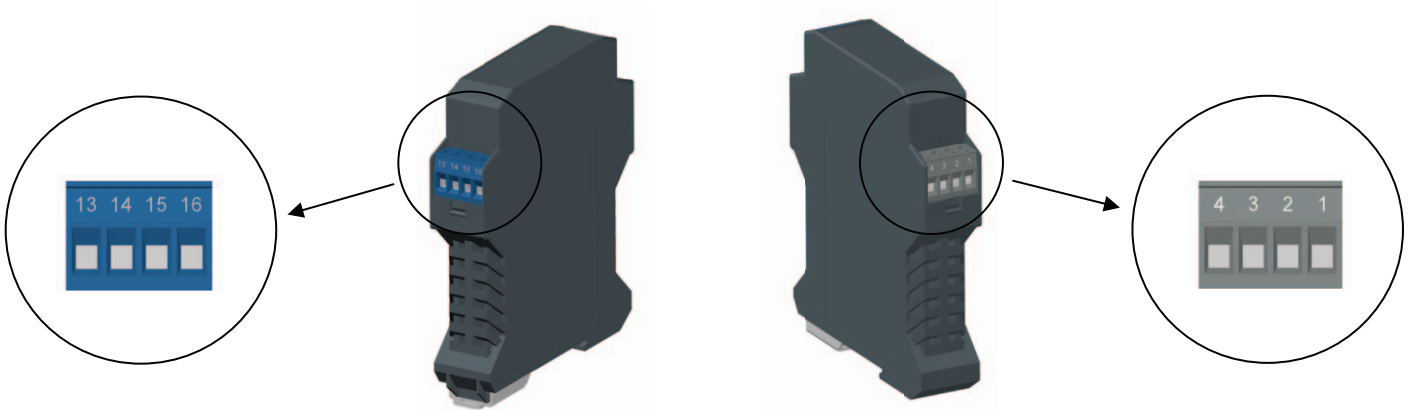

HAZARDOUS AREA

SAFE AREA

- | | |
|-----------|--|
| 13 | + Output Ch 1 for Solenoid Valve or
+ Output Ch 1 for 2 wire Device |
| 14 | - Output Ch 1 for Solenoid Valve or
- Output Ch 1 for 2 wire Device |
| 15 | + Output Ch 1 for Solenoid Valve or
+ Output Ch 1 for 2 wire Device |
| 16 | - Output Ch 1 for Solenoid Valve or
- Output Ch 1 for 2 wire Device |

- | | |
|----------|-----------------------|
| 1 | Not used |
| 2 | Not used |
| 3 | + Power Supply 24 Vdc |
| 4 | - Power Supply 24 Vdc |

Parameters Table

In the system safety analysis, always check the Hazardous Area/Hazardous Locations devices to conform with the related system documentation, if the device is Intrinsically Safe check its suitability for the Hazardous Area/Hazardous Locations and gas group encountered and that its maximum allowable voltage, current, power (U_i/V_{max} , I_i/I_{max} , P_i/P_i) are not exceeded by the safety parameters (U_o/V_{oc} , I_o/I_{sc} , P_o/P_o) of the PSD1001C Associated Apparatus connected to it. Also consider the maximum operating temperature of the field device, check that added connecting cable and field device capacitance and inductance do not exceed the limits (C_o/C_a , L_o/L_a , L_o/R_o) given in the Associated Apparatus parameters for the effective gas group. See parameters on enclosure side and the ones indicated in the table below:

PSD1001C Terminals		PSD1001C Associated Apparatus Parameters		Must be	Hazardous Area/ Hazardous Locations Device Parameters
Ch1	13/15 - 14/16	$U_o / V_{oc} = 23.6 \text{ V}$		\leq	U_i / V_{max}
Ch1	13/15 - 14/16	$I_o / I_{sc} = 352.8 \text{ mA}$		\leq	I_i / I_{max}
Ch1	13/15 - 14/16	$P_o / P_o = 1674 \text{ mW}$		\leq	P_i / P_i
PSD1001C Terminals		PSD1001C Associated Apparatus Parameters		Must be	Hazardous Area/ Hazardous Locations Device + Cable Parameters
Ch1	13/15 - 14/16	$C_o / C_a = 970 \text{ nF}$ $C_o / C_a = 3.5 \text{ } \mu\text{F}$	(IIB-C) (IIA-D)	\geq	$C_i / C_i \text{ device} + C \text{ cable}$
Ch1	13/15 - 14/16	$L_o / L_a = 1.1 \text{ mH}$ $L_o / L_a = 2.2 \text{ mH}$	(IIB-C) (IIA-D)	\geq	$L_i / L_i \text{ device} + L \text{ cable}$
Ch1	13/15 - 14/16	$L_o / R_o = 68.6 \text{ } \mu\text{H}/\Omega$ $L_o / R_o = 137.2 \text{ } \mu\text{H}/\Omega$	(IIB-C) (IIA-D)	\geq	$L_i / R_i \text{ device and}$ $L \text{ cable} / R \text{ cable}$

NOTE for USA and Canada:
 IIB equal to Gas Groups C, D, E, F and G
 IIA equal to Gas Groups D, E, F and G

For installations in which both the C_i and L_i of the Intrinsically Safe apparatus exceed 1 % of the C_o and L_o parameters of the Associated Apparatus (excluding the cable), then 50 % of C_o and L_o parameters are applicable and shall not be exceeded (50 % of the C_o and L_o become the limits which must include the cable such that $C_i \text{ device} + C \text{ cable} \leq 50 \%$ of C_o and $L_i \text{ device} + L \text{ cable} \leq 50 \%$ of L_o).

If the cable parameters are unknown, the following value may be used: Capacitance 60pF per foot (180pF per meter), Inductance 0.20 μ H per foot (0.60 μ H per meter).

The Intrinsic Safety Entity Concept allows the interconnection of Intrinsically Safe devices approved with entity parameters not specifically Examined in combination as a system when the above conditions are respected.

For Division 1 and Zone 0 installations, the configuration of Intrinsically Safe Equipment must be FM approved under Entity Concept (or third party approved);

for Division 2 installations, the configuration of Intrinsically Safe Equipment must be FM approved under non-incendive field wiring or Entity Concept (or third party approved).

Function Diagram

HAZARDOUS AREA ZONE 0 (ZONE 20) GROUP IIB,
 HAZARDOUS LOCATIONS CLASS I, DIVISION 1, GROUPS C, D,
 CLASS II, DIVISION 1, GROUPS E, F, G, CLASS III, DIVISION 1,
 CLASS I, ZONE 0, GROUP IIB

SAFE AREA, ZONE 2 GROUP IIC T4,
 NON HAZARDOUS LOCATIONS, CLASS I, DIVISION 2,
 GROUPS A, B, C, D T-Code T4, CLASS I, ZONE 2, GROUP IIC T4

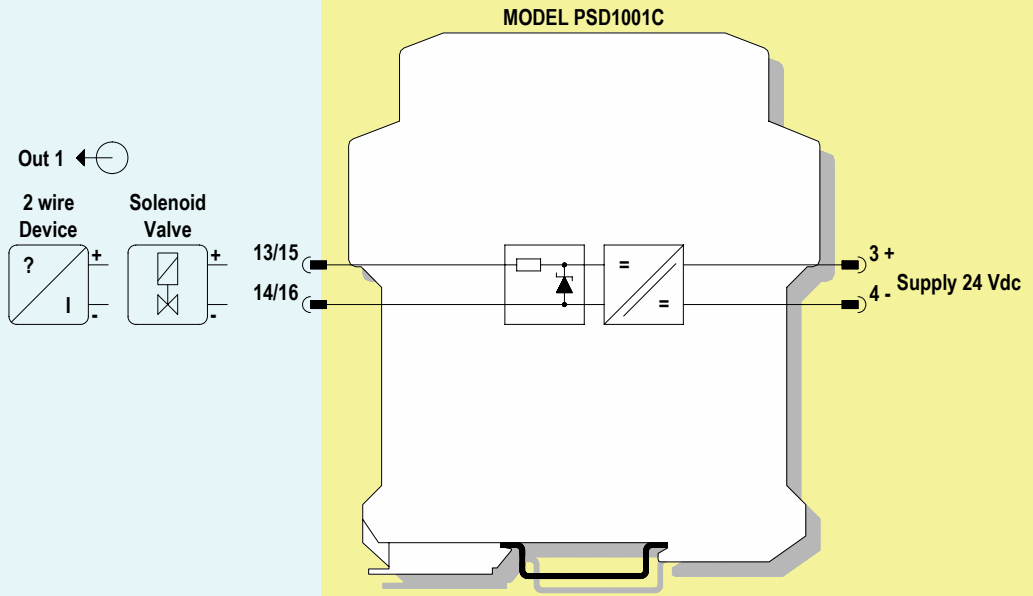

Warning:

PSD1001C is an isolated Intrinsically Safe Associated Apparatus installed into standard EN50022 T35 DIN Rail located in Safe Area/Non Hazardous Locations or Zone 2, Group IIC, Temperature Classification T4, Class I, Division 2, Groups A, B, C, D, Temperature Code T4 and Class I, Zone 2, Group IIC, IIB, IIA Temperature Code T4 Hazardous Area/Hazardous Locations (according to EN/IEC60079-15, FM Class No. 3611, CSA-C22.2 No. 213-M1987, CSA-E60079-15) within the specified operating temperature limits Tamb -20 to +60 °C, and connected to equipment with a maximum limit for AC power supply Um of 250 Vrms.

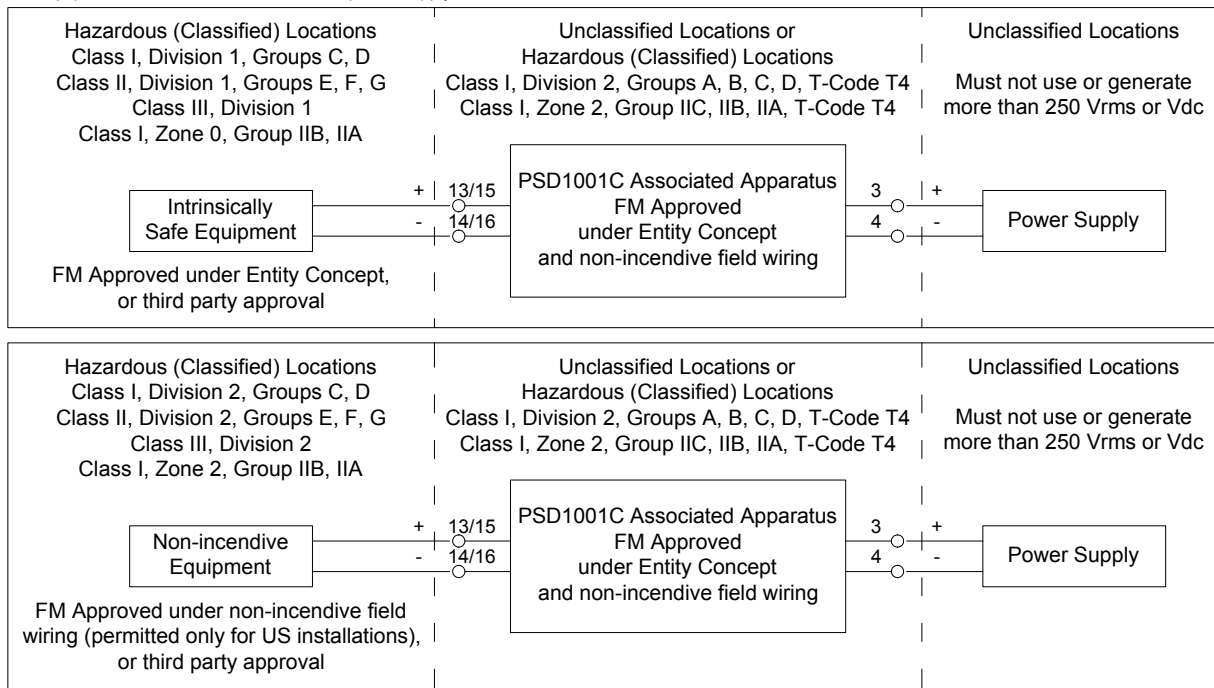

Non-incendive field wiring is not recognized by the Canadian Electrical Code, installation is permitted in the US only.

For installation of the unit in a Class I, Division 2 or Class I, Zone 2 location, the wiring between the control equipment and the PSD1001C associated apparatus shall be accomplished via conduit connections or another acceptable Division 2, Zone 2 wiring method according to the NEC and the CEC.

Not to be connected to control equipment that uses or generates more than 250 Vrms or Vdc with respect to earth ground.

PSD1001C must be installed, operated and maintained only by qualified personnel, in accordance to the relevant national/international installation standards (e.g. IEC/EN60079-14 Electrical apparatus for explosive gas atmospheres - Part 14: Electrical installations in hazardous areas (other than mines), BS 5345 Pt4, VDE 165, ANSI/ISA RP12.06.01 Installation of Intrinsically Safe System for Hazardous (Classified) Locations, National Electrical Code NEC ANSI/NFPA 70 Section 504 and 505, Canadian Electrical Code CEC) following the established installation rules, particular care shall be given to segregation and clear identification of I.S. conductors from non I.S. ones. De-energize power source (turn off power supply voltage) before plug or unplug the terminal blocks when installed in Hazardous Area/Hazardous Locations or unless area is known to be nonhazardous.

Warning: substitution of components may impair Intrinsic Safety and suitability for Division 2, Zone 2.

Explosion Hazard: to prevent ignition of flammable or combustible atmospheres, disconnect power before servicing or unless area is known to be nonhazardous.

Failure to properly installation or use of the equipment may risk to damage the unit or severe personal injury.

The unit cannot be repaired by the end user and must be returned to the manufacturer or his authorized representative. Any unauthorized modification must be avoided.

Operation

The PSD1001C provides an output (see the output diagram on data sheet for details of voltage and current to the load) in Hazardous Area/Hazardous Locations to drive Intrinsically Safe loads, typically transmitter for multiplexer unit or local indication without signal repetition, display unit or other high power devices.

Presence of supply power is displayed by a green signaling LED.

Installation

PSD1001C is a IIB group power supply for field devices housed in a plastic enclosure suitable for installation on T35 DIN Rail according to EN50022.

PSD1001C unit can be mounted with any orientation over the entire ambient temperature range, see section "Installation in Cabinet" and "Installation of Electronic Equipments in Cabinet" Instruction Manual D1000 series for detailed instructions.

Electrical connection of conductors up to 2.5 mm² are accommodated by polarized plug-in removable screw terminal blocks which can be plugged in/out into a powered unit without suffering or causing any damage (**for Zone 2 or Division 2 installations check the area to be nonhazardous before servicing**).

The wiring cables have to be proportionate in base to the current and the length of the cable.

On the section "Function Diagram" and enclosure side a block diagram identifies all connections.

Identify the function and location of each connection terminal using the wiring diagram on the corresponding section, as an example:

Connect 24 Vdc power supply positive at terminal "3" and negative at terminal "4".

Connect positive output at terminal "13" or "15" and negative output at "14" or "16".

Intrinsically Safe conductors must be identified and segregated from non I.S. and wired in accordance to the relevant national/international installation standards (e.g. EN/IEC60079-14 Electrical apparatus for explosive gas atmospheres - Part 14: Electrical installations in hazardous areas (other than mines), BS 5345 Pt4, VDE 165, ANSI/ISA RP12.06.01 Installation of Intrinsically Safe System for Hazardous (Classified) Locations, National Electrical Code NEC ANSI/NFPA 70 Section 504 and 505, Canadian Electrical Code CEC), make sure that conductors are well isolated from each other and do not produce any unintentional connection.

The enclosure provides, according to EN60529, an IP20 minimum degree of mechanical protection (or similar to NEMA Standard 250 type 1) for indoor installation, outdoor installation requires an additional enclosure with higher degree of protection (i.e. IP54 to IP65 or NEMA type 12-13) consistent with the effective operating environment of the specific installation.

Units must be protected against dirt, dust, extreme mechanical (e.g. vibration, impact and shock) and thermal stress, and casual contacts.

If enclosure needs to be cleaned use only a cloth lightly moistened by a mixture of detergent in water.

Electrostatic Hazard: to avoid electrostatic hazard, the enclosure of PSD1001C must be cleaned only with a damp or antistatic cloth.

Any penetration of cleaning liquid must be avoided to prevent damage to the unit. Any unauthorized card modification must be avoided.

According to EN61010, PSD1001C series must be connected to SELV or SELV-E supplies.

Start-up



Before powering the unit check that all wires are properly connected, particularly supply conductors and their polarity, input and output wires, also check that Intrinsically Safe conductors and cable trays are segregated (no direct contacts with other non I.S. conductors) and identified either by color coding, preferably blue, or by marking. Check conductors for exposed wires that could touch each other causing dangerous unwanted shorts. Turn on power, the "power on" green led must be lit and the output must provide output power to the Hazardous Area.

Power Dissipation of PSD1001C Isolators

Section "Technical Data" of PSD1001C isolator specifies the current consumption (maximum current from the nominal power supply, typical 24 Vdc, in normal operation); this data serves to dimension the current rating of the power supply unit. Section "Technical Data" indicates also the maximum power consumption (maximum power required from the power supply in the worst (abnormal) operating conditions like for example supply voltage at 30 Vdc, short circuit on the outputs and on the inputs terminals). The power dissipated **Pd** inside the enclosure for analog signal isolators is: **Pd = Current Consumption (A) * Supply Voltage (V) - Power Dissipated into the input/output loads**. Analog signal isolators have higher dissipation than digital signal isolators. In analog signal isolators each transmitter requires and dissipates 15 V * 0.02 A = 0.3 W. Usually the loads outside the isolator dissipate 1/3 of the total power used. Isolators are not running at the maximum current all at the same time, the average power consumption of a multitude of isolators can be considered to be only 70 % of the value obtained from the section "Technical Data". Considering the 1/3 load power and the 70 % above discussed, the power effectively dissipated internally by the isolators can therefore become 1/2 of the actual power delivered by the power supply. Digital barriers dissipate all the supply power inside the enclosure consequently the total power dissipation into a cabinet, with mixed analog and digital barriers, is determined by the number of channels more than by the number of isolator enclosures. The following tables give advises for the DIN rail orientation (vertical or horizontal) of the barriers mounting, PSD1001C (single channel) isolators, installed on DIN rail, bus or custom board assembly.

A) Cabinet with Natural Ventilation

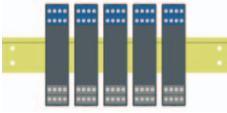
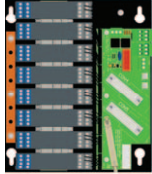
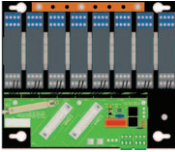

Maximum recommended ambient temperature in °C depending on barrier type and installation method:

Type of Isolator	Single unit Installation	Installation of Multiple units with DIN-rail Bus		Installation on Custom Boards	
	Any orientation	Vertical	Horizontal	Vertical	Horizontal
					
PSD1001C	60°C	Not recommended ⁽¹⁾	Not recommended ⁽¹⁾	Not recommended ⁽¹⁾	Not recommended ⁽¹⁾

⁽¹⁾ Installation is not recommended since it would significantly shorten the units life and increase the probability of failures.

B) Cabinet with Forced Ventilation

Maximum recommended ambient temperature in °C depending on barrier type and installation method:

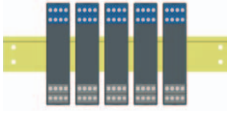
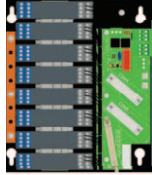
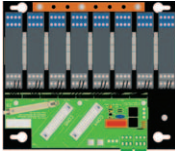
Type of Isolator	Single unit Installation	Installation of Multiple units with DIN-rail Bus		Installation on Custom Boards	
	Any orientation	Vertical	Horizontal	Vertical	Horizontal
					
PSD1001C	60°C	Not recommended ⁽¹⁾	Not recommended ⁽¹⁾	30°C	40°C

⁽¹⁾ Installation is not recommended since it would significantly shorten the units life and increase the probability of failures.