



# INSTRUCTION MANUAL

4 A SIL 3 Relay Output Module for F & G Load,  
with open/short circuit diagnostic  
DIN-Rail and Termination Board, Model D5294S



## Characteristics

**General Description:** The D5294S is a relay module suitable for the switching of safety related circuits, up to SIL 3 level according to IEC 61508 for high risk industries.

It provides isolation between input and output contacts. Line input monitoring, to allow DCS/PLC line monitoring function, permits a wide compatibility towards different DCS/PLC.

Driving line pulse testing, executed by DCS/PLC, is permitted by a dedicated internal circuit, to prevent relay and LED flickering. Relay coil short circuit is detected from module.

D5294S has 2+2 SPST relay contacts connected in series and then in parallel to avoid spurious trip and to increase availability (see function diagram).

High availability SIL 3 Safety Function for F&G load is available at Terminal Blocks 13-14. When the driving signal is low (0 Vdc), the relay is de-energized, contacts at terminals 13-15 and 14-16 are open and load is de-energized. When the driving signal is high (24 Vdc), the relay is energized, contacts at terminals 13-15 and 14-16 are closed, the load is energized. Load is isolated from supply on both polarities: +/AC, -/AC.

**Load and Line Diagnostic:** Line and load short/open circuit detection is provided, with solenoid resistance measurement, even in presence of series connected diodes.

A patent pending proprietary resistance measuring technique performs the load short and open circuit diagnosis in de-energized load status, for DC or AC supply systems.

Load RMS voltage (before and after its energization) and current are measured from module.

Voltage, current and solenoid resistance values are automatically acquired at start up. User configurable limits set the minimum and maximum values of load resistance, supply voltage (DC or AC) and load current consumption. Earth leakage detection on both AC phases is available in de-energized load condition.

An external resistor can be added to reflect diagnostic conditions on the PLC Input. The resistance value can be tailored according to the PLC requirements.

All diagnostic conditions, that detect a fault on line and load, open the fault relay contacts and are also available from a RS485 Modbus output to identify specific fault.

Mounting on standard DIN-Rail, with or without Power Bus, or on customized Termination Boards, in Safe Area or in Zone 2.

## Technical Data

**Supply:** 24 Vdc nom (21.6 to 27.6 Vdc) reverse polarity protected, ripple within voltage limits  $\leq 5$  Vpp, 2 A time lag fuse internally protected.

**Current consumption @ 24 V:** 60 mA typical, with channel de-energized and no fault.

**Power dissipation:** 1.5 W typical.

**Isolation (Test Voltage):** Output/Input 2.5 KV; Output/Supply 2.5 KV; Output/Fault Outputs 2.5 KV; Output/RS485 Modbus 2.5 KV; Input/Supply 500 V; Input/Fault Output 1 500 V;

Input/Fault Output 2.5 KV; Input/RS485 Modbus 500 V; Supply/Fault Output 1 500 V; Supply/Fault Output 2.5 KV; Supply/RS485 Modbus 500 V.

**Input:** 24 Vdc nom (21.6 to 27.6 Vdc) reverse polarity protected, ripple within voltage limits  $\leq 5$  Vpp.

**Line input monitoring:** to allow DCS/PLC line monitoring function (pulse test).

**Current consumption @ 24 V:** 45 mA with relay energized, typical.

**Power dissipation:** 1.1 W with 24 V input voltage, relay energized, typical.

**Output:** voltage free 2+2 SPST relay contact (2 paralleled contacts in series) at terminals 13-15 and 14-16, close when relay energized, open in de-energized condition.

**Contact material:** Ag Alloy (Cd free) or AgSnO<sub>2</sub>.

**Contact rating:** 4 A 250 Vac 1000 VA, 4 A 250 Vdc 120 W (resistive load).

**Contact inrush current:** 6 A at 24 Vdc, 250 Vac.

**Mechanical / Electrical life:**  $5 \cdot 10^6 / 3 \cdot 10^4$  operation, typical.

**Bounce time NO / NC contact:** 3 / 8 ms, typical.

**Frequency response:** 10 Hz maximum.

**Fault detection:** load and line short/open circuit monitoring

**Short output detection:** programmable load resistance (30  $\Omega$  to 5 K $\Omega$  typical).

**Open output detection:** programmable load resistance (30  $\Omega$  to 5 K $\Omega$  typical).

**Fault signalling:** voltage free NE 1 + 1 SPST relay contacts (closed in normal status), output de-energized (contacts opened) in fault condition.

**Fault 1 output rating:** 500 mA 30 Vac 15 VA, 500 mA 50 Vdc 25 W (resistive load).

**Fault 2 output rating:** 3 A 250 Vac 750 VA, 3 A 125 Vdc 120 W (resistive load).

**Response time:** 1 sec typical.

**Modbus Output:** measure data, load and line diagnostic monitoring.

Modbus RTU protocol up to 115.2 Kbit/s with RS-485 connection on terminal blocks and Power Bus connector.

**Terminating impedance:**

100  $\Omega$  DIP-switch selectable, pull-up and pull-down resistor DIP-switch selectable in addition to termination resistor.

**Transmission speed:** 4.8, 9.6, 19.2, 38.4, 57.6, 115.2 Kbit/s.

**Transmission cable length:**  $\leq 1200$  m up to 93.75 Kbit/s,  $\leq 1000$  m up to 115.2 Kbit/s.

**Compatibility:**

 CE mark compliant, conforms to 94/9/EC Atex Directive and to 2004/108/CE EMC Directive.

**Environmental conditions:**

**Operating:** temperature limits - 40 to + 60 °C, relative humidity 95 %, up to 55 °C.

**Storage:** temperature limits - 45 to + 80 °C.

**Safety Description:**



**ATEX:** II 3G Ex nA nC IIC T4 Gc,

**IECEX:** Ex nA nC IIC T4 Gc non-sparking electrical equipment.

-40 °C  $\leq$  Ta  $\leq$  60 °C.

**Approvals:** BVS 10 ATEX E 114 conforms to EN60079-15, IECEx BVS 10.0072 X conforms to IEC60079-15.

Russia according to GOST 12.2.007.0-75, R 51330.0-99, R 51330.14-99 2ExnAnCIIC T4 X.

Ukraine according to GOST 12.2.007.0, 22782.0, 22782.3, 22782.5 2ExslIT4 X.

TUV Certificate No. C-IS-204194-01, SIL 2 / SIL 3 conforms to IEC61508.

**Mounting:** T35 DIN-Rail according to EN50022, with or without Power Bus or on customized Termination Board.

**Weight:** about 170 g.

**Connection:** by polarized plug-in disconnect screw terminal blocks to accommodate terminations up to 2.5 mm<sup>2</sup>.

**Location:** Safe Area/Non Hazardous Locations or Zone 2, Group IIC T4 installation.

**Protection class:** IP 20.

**Dimensions:** Width 22.5 mm, Depth 123 mm, Height 120 mm.

**DC Load breaking capacity:**

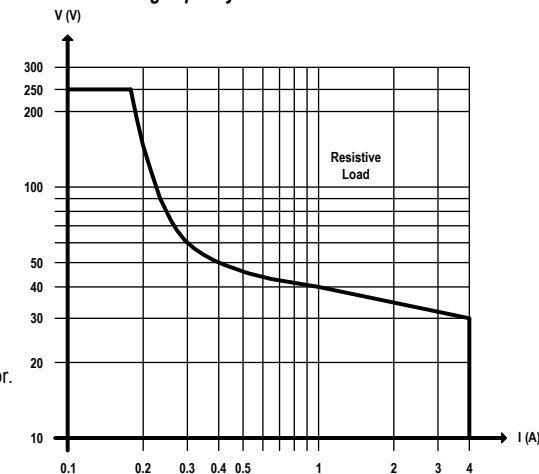

## Programming

The module is fully programmable to set the operation parameters from PC by the GM Pocket Portable Adapter PPC5092 via USB serial line and SWC5090 Configurator software.

Measured values and diagnostic alarms can be read on both serial configuration or Modbus output line.

**Measuring and Set limits:** working voltage and load characteristics to indicate normal working condition. Parameters are:

- Line Voltage value from 10 to 250 Vdc or Vac.

- Load Current for energized condition.

- Load Resistance for de-energized condition.

- Isolation resistance (as Earth Leakage measure) in de-energized load condition.

**Type of Faults:** programmability of which type of faults can deactivate the diagnostic relay output.

Each of the fault condition can be programmed to de-energize the fault relay output. Faults are:

- Relay coil short circuit.

- Line Voltage value out of boundary range.

- Load Current value, in energized condition, out of boundary range.

- Load Resistance value, in de-energized condition, out of boundary range.

- Isolation resistance (as Earth Leakage measure) below the programmed limit.

## Ordering information

**Model:** D5294S

Power Bus and DIN-Rail accessories:

Connector JDFT050

Terminal block male MOR017

Cover and fix MCHP196

Terminal block female MOR022

Operating parameters are programmable from PC by the GM Pocket Portable Adapter PPC5092 via USB serial line and SWC5090 Configurator software.

## Front Panel and Features

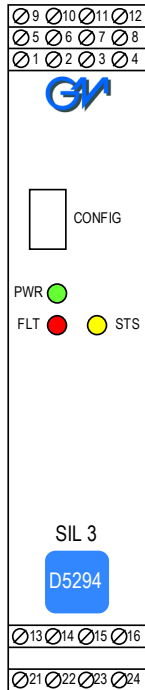

- SIL 3 according to IEC 61508 for Tproof = 7 / 14 yrs (10 / 20 % of total SIF).
- SIL 2 according to IEC 61508 for Tproof = 20 yrs (10 % of total SIF).
- PFDavg (1 year) 1.40 E-05, SFF 99.38 % for F&G Load.
- Installation in Zone 2.
- Line input monitoring.
- Relay coil short circuit detection.
- Line and Load short/open circuit detection.
- Solenoid resistance measurement even in presence of serial connected diodes (proprietary patent pending resistance measuring technique).
- RMS measurement of voltage (before and after load energization) and current supplied to the load via relay contacts.
- Automatic acquisition of voltage, current and solenoid resistance values at start up.
- Earth leakage detection on both ac phases in de-energized load condition.
- 4 A high availability SIL 3 contacts for F&G load.
- 6 A inrush current at 24 Vdc / 250 Vac.
- Input/Output/Supply isolation.
- EMC Compatibility to EN61000-6-2, EN61000-6-4, EN61326-1, EN61326-3-1 for safety system.
- ATEX, IECEX, Russian and Ukrainian Certifications.
- Simplified installation using standard DIN-Rail and plug-in terminal blocks, with or without Power Bus, or customized Termination Boards.

## Terminal block connections

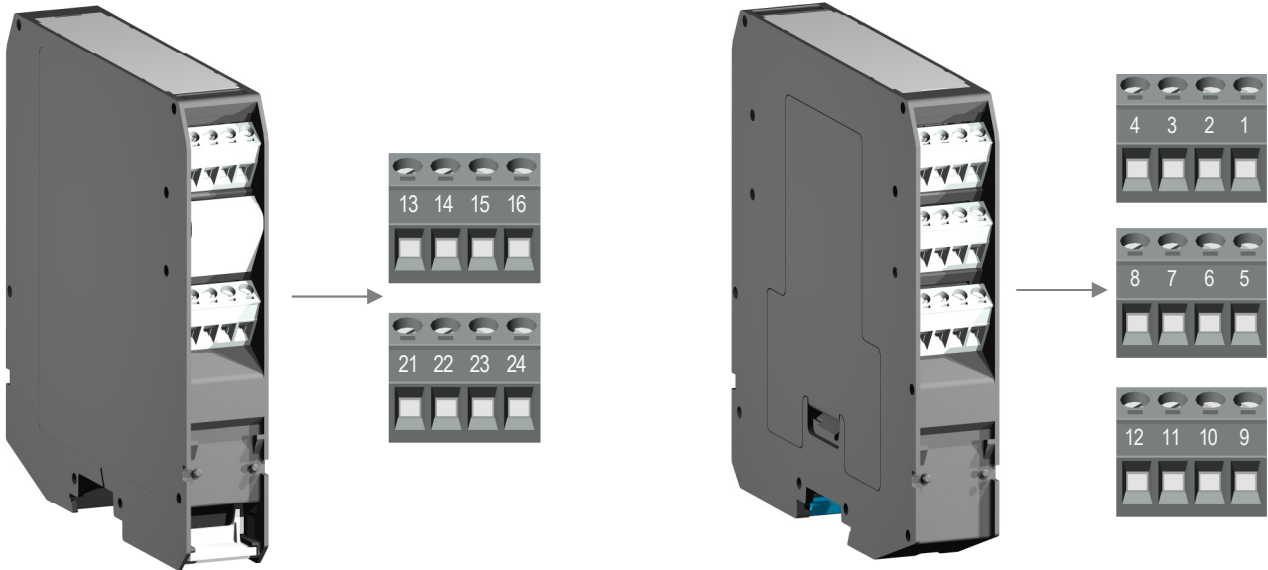

### SAFE AREA

<b>13</b>	(SIL 3) + Output Fire & Gas Load
<b>14</b>	(SIL 3) - Output Fire & Gas Load
<b>15</b>	+ Load Power DC/AC
<b>16</b>	- Load Power DC/AC
<b>21</b>	Earth
<b>22</b>	Not used
<b>23</b>	Not used
<b>24</b>	Not used

<b>1</b>	+ Input
<b>2</b>	- Input
<b>3</b>	Fault Output 1 (30 V, 500 mA) or optional external testing resistor
<b>4</b>	Fault Output 1 (30 V, 500 mA) or optional external testing resistor
<b>5</b>	A- Modbus Input/Output RS485
<b>6</b>	B+ Modbus Input/Output RS485
<b>7</b>	A- Modbus Input/Output RS485 (internally connected to terminal 5)
<b>8</b>	B+ Modbus Input/Output RS485 (internally connected to terminal 6)
<b>9</b>	+ Power Supply 24 Vdc
<b>10</b>	- Power Supply 24 Vdc
<b>11</b>	Fault Output 2 (250 V, 3 A)
<b>12</b>	Fault Output 2 (250 V, 3 A)

## Function Diagram

SAFE AREA, ZONE 2 GROUP IIC T4

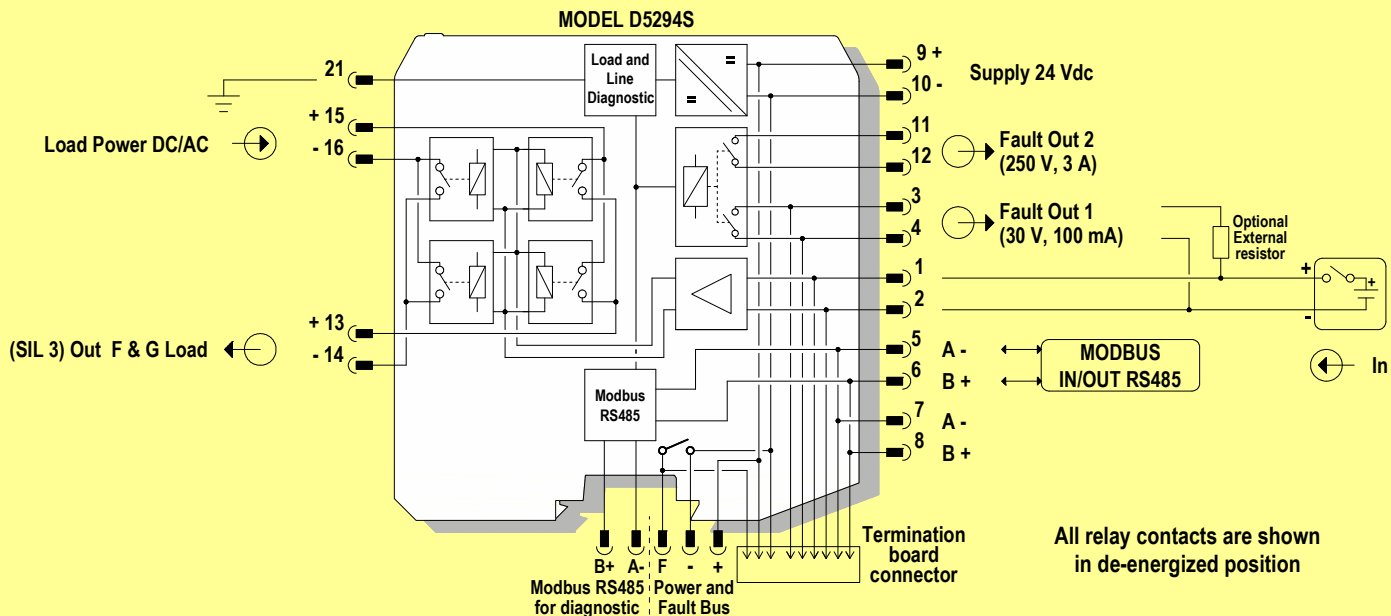

**To prevent relay contacts from damaging, connect an external protection (fuse or similar), chosen according to the relay breaking capacity diagram.**

## Application

### Application for D5294S - SIL 3 F&G Load

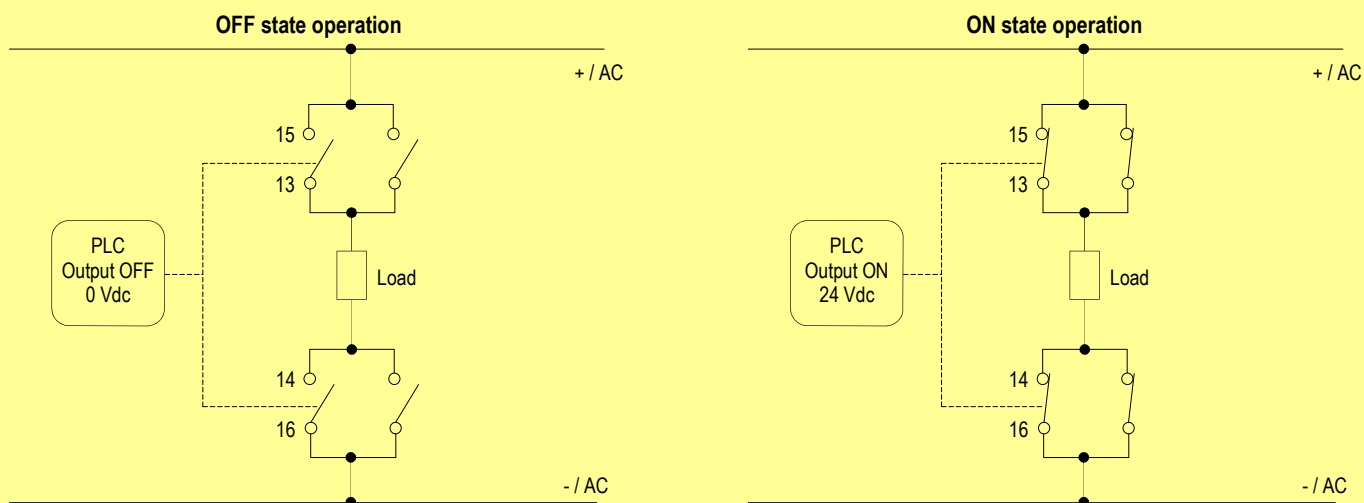

**Contacts 13-15 and 14-16:** in OFF operation the relay is de-energized, contacts are open, load is de-energized.

**Contacts 13-15 and 14-16:** in ON operation the relay is energized, contacts are closed, load is energized.

**To prevent relay contacts from damaging, connect an external protection (fuse or similar), chosen according to the relay breaking capacity diagram.**

## Warning

D5294S is an electrical apparatus installed into standard EN50022 T35 DIN-Rail located in Safe Area or Zone 2, Group IIC, Temperature Classification T4, Hazardous Area (according to EN/IEC60079-15) within the specified operating temperature limits Tamb - 40 to +60 °C.

D5294S must be installed, operated and maintained only by qualified personnel, in accordance to the relevant national/international installation standards (e.g. IEC/EN60079-14 Electrical apparatus for explosive gas atmospheres - Part 14: Electrical installations in hazardous areas (other than mines)), following the established installation rules.

De-energize power source (turn off power supply voltage) before plug or unplug the terminal blocks when installed in Hazardous Area or unless area is known to be nonhazardous.

**Warning: substitution of components may impair suitability for Zone 2.**

**Warning: de-energize main power source (turn off power supply voltage) and disconnect plug-in terminal blocks before opening the enclosure to avoid electrical shock when connected to live hazardous potential.**

**Explosion Hazard: to prevent ignition of flammable or combustible atmospheres, disconnect power before servicing or unless area is known to be nonhazardous.**

Failure to properly installation or use of the equipment may risk to damage the unit or severe personal injury.

The unit cannot be repaired by the end user and must be returned to the manufacturer or his authorized representative.

Any unauthorized modification must be avoided.

## Operation

The single channel 4 A Relay Output D5294S is a relay module suitable for the switching of safety related circuits, up to SIL 3 level according to IEC 61508 for high risk industries. It provides isolation between input and output contacts. D5294S has 2+2 SPST relay contacts connected in series and then in parallel to avoid spurious trip and to increase availability (see function diagram). High availability SIL 3 Safety Function for F&G load is available at Terminal Blocks 13-14. When the driving signal is low (0 Vdc), the relay is de-energized, contacts at terminals 13-15 and 14-16 are open and load is de-energized. When the driving signal is high (24 Vdc), the relay is energized, contacts at terminals 13-15 and 14-16 are closed and the load is energized.

Presence of diagnostic circuit power supply, status of input / output channel (energized or de-energized), as well as any type of fault condition (line and load short/open circuit, relay coil short circuit, etc.) are displayed by related signalling LEDs: green power supply, yellow for status channel and red for fault.

## Installation

D5294S is a relay output module housed in a plastic enclosure suitable for installation on T35 DIN-Rail according to EN50022, with or without Power Bus or on customized Termination Board. D5294S unit can be mounted with any orientation over the entire ambient temperature range.

Electrical connection of conductors up to 2.5 mm<sup>2</sup> are accommodated by polarized plug-in removable screw terminal blocks which can be plugged in/out into a powered unit without suffering or causing any damage (**for Zone 2 installations check the area to be nonhazardous before servicing**).

The wiring cables have to be proportionate in base to the current and the length of the cable.

On the section "Function Diagram" and enclosure side a block diagram identifies all connections.

Identify the function and location of each connection terminal using the wiring diagram on the corresponding section, as an example:

Connect 24 Vdc power supply positive at terminal "9" and negative at terminal "10".

Connect positive input at terminal "1" and negative input at "2".

Connect Fault output 1 (30 V, 500mA) at terminals "3" and "4" and Fault output 2 (250 V, 3A) at terminals "11" and "12".

Connect A- Modbus RS845 for diagnostic at terminal "5" or "7" and B+ at terminal "6" or "8".

Connect positive output Fire & Gas load at terminal "13" and negative at terminal "14".

Connect positive Load Power DC/AC at terminal "15" and negative at terminal "16".

Connect ground at terminal "21".

Installation and wiring must be in accordance to the relevant national or international installation standards (e.g. IEC/EN60079-14 Electrical apparatus for explosive gas atmospheres Part 14: Electrical installations in hazardous areas (other than mines)), make sure that conductors are well isolated from each other and do not produce any unintentional connection.

Connect 2+2 SPST relay contacts checking the load rating to be within the contact maximum rating 4 A 250 Vac 1000 VA, 4 A 250 Vdc 120 W (resistive load).

**To prevent relay contacts from damaging, connect an external protection (fuse or similar), chosen according to the relay breaking capacity diagram on data sheet.**

The enclosure provides, according to EN60529, an IP20 minimum degree of mechanical protection (or similar to NEMA Standard 250 type 1) for indoor installation, outdoor installation requires an additional enclosure with higher degree of protection (i.e. IP54 to IP65 or NEMA type 12-13) consistent with the effective operating environment of the specific installation.

Units must be protected against dirt, dust, extreme mechanical (e.g. vibration, impact and shock) and thermal stress, and casual contacts.

If enclosure needs to be cleaned use only a cloth lightly moistened by a mixture of detergent in water.

**Electrostatic Hazard: to avoid electrostatic hazard, the enclosure of D5294S must be cleaned only with a damp or antistatic cloth.**

Any penetration of cleaning liquid must be avoided to prevent damage to the unit. Any unauthorized card modification must be avoided.

According to EN61010, D5294 must be connected to SELV or SELV-E supplies.

Relay output contact must be connected to load non exceeding category II overvoltage limits.

**Warning: de-energize main power source (turn off power supply voltage) and disconnect plug-in terminal blocks before opening the enclosure to avoid electrical shock when connected to live hazardous potential.**

## Start-up

Before powering the unit check that all wires are properly connected, particularly supply conductors and their polarity, input and output wires. Check conductors for exposed wires that could touch each other causing dangerous unwanted shorts. Turn on power for diagnostic circuit, the "power on" green led must be lit. Enabling input, the channel status yellow led must be lit and load circuit must be energized because 2+2 SPST relay output contacts are closed. Instead, disabling input, the channel status yellow led must be turned off and load circuit must be de-energized because 2+2 SPST relay output contacts are open.

## Configuration

For configuration of T-proof relays testing and termination + pull-down or pull-up resistors of Modbus communication, some DIP Switches are located on component side of pcb. These switches allow the T-proof relays test (SW1 dip-switch: 1-2-3-4 set "ON") and termination + pull-down or pull-up resistors of Modbus communication (SW2 dip-switch: 1-2 set "ON" to enable 100 Ω between A- and B+; 3 set "ON" to enable pull-down resistor; 4 set "ON" to enable pull-up resistor).

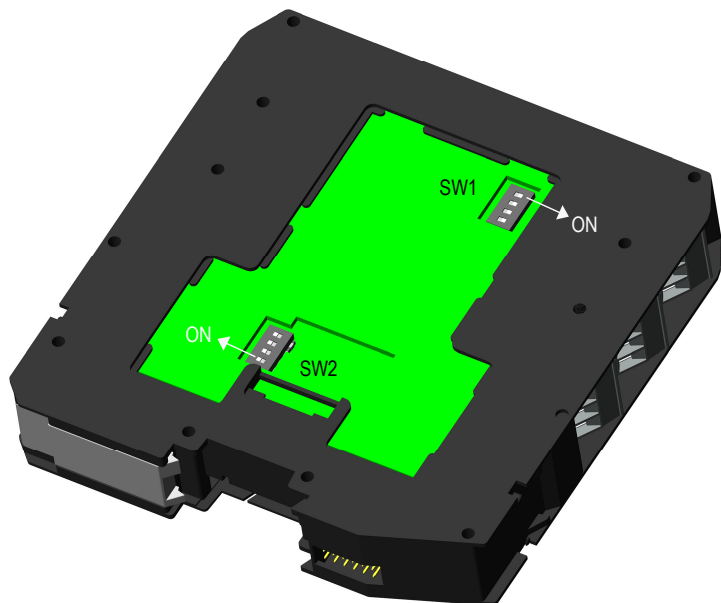

### SW1 Dip switch configuration

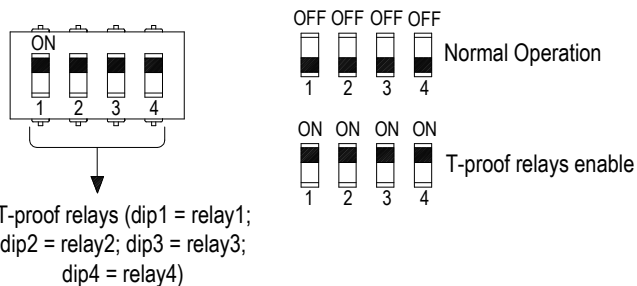

**WARNING:** after T-proof test, dip-switch 1-2-3 must be set to "OFF" position for normal operation.

### SW2 Dip switch configuration

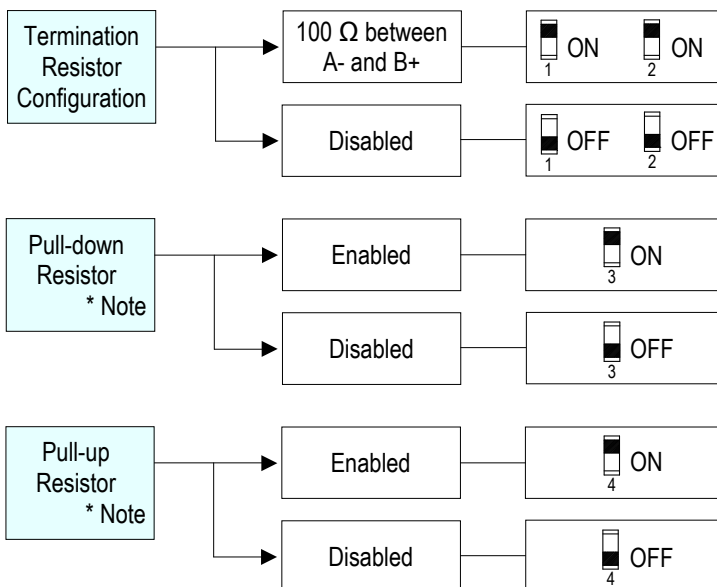
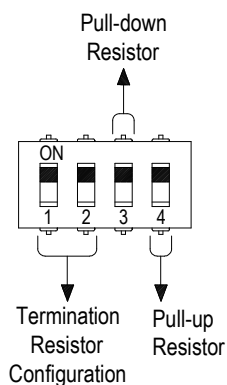

\* Note: termination resistor must be enabled to activate pull-down or pull-up resistor.



## Testing procedure at T-proof

The proof test shall be performed to reveal dangerous faults which are undetected by diagnostic. This means that it is necessary to specify how dangerous undetected faults, which have been noted during the FMEDA, can be detected during proof test. Before of specific Proof test, execute the following general proof test: connect load supply lines to terminal blocks "15" (for +/AC) and "16" (-/AC); connect F&G output load to terminal blocks "13" (as positive terminal) and "14" (as negative terminal); connect DCS/PLC signal to input channel terminal blocks "1" (as positive terminal) and "2" (as negative terminal). Then, verify the input-to-output functionality: output load is energized by supplying the input channel, while shutdown of the input channel de-energizes the load. The channel functionality must be verified for a min to max input voltage change (21.6 to 27.6 Vdc). Instead, the specific Proof test consists of the following steps:

Steps	Action
1	Bypass the safety-related PLC or take other appropriate action to avoid a false trip when removing the unit for test.
2	<p>Disconnect load supply lines to terminal blocks "15" - "16" and the output load to terminal blocks "13" - "14". Then, connect: an ohmmeter (Ohm. A) between terminal blocks "15" - "13" and another one (Ohm. B) between terminal blocks "16" - "14". The use of four relays for this single channel, requires to control any single relay coil by means of internal SW1 DIP-switches (n°1, 2, 3, 4) and to check the ohmic continuity of the contacts, as described in the following procedure:</p> <ol style="list-style-type: none"> <li>Do not supply the input channel (terminals "1"- "2") of the unit under test and verify that ohmmeters Ohm. A and Ohm. B measure absence of ohmic continuity (i.e. both +/AC and -/AC load lines are interrupted because all NO contacts are open: <b>1<sup>st</sup> requisite is verified</b>). For both ohmmeters Ohm. A or Ohm. B, these measures could also be true if only one of two relay contacts in parallel is open and other is blocked (for welding) into open position: this will be verified by testing the channel when input is supplied, as described in the point 3 of this procedure. Instead, the presence of ohmic continuity measured by ohmmeter Ohm. A or Ohm. B, implies that at least one relay contact is blocked (for welding) into closed position: this could be verified disassembling and individually testing each relay.</li> <li>Supply the input channel (terminals "1"- "2") of the unit under test and verify that ohmmeters Ohm. A and Ohm. B measure presence of ohmic continuity (i.e. both +/AC and -/AC load lines are not interrupted because NO contacts are closed: <b>2<sup>nd</sup> requisite is verified</b>). The absence of ohmic continuity measured by ohmmeter Ohm. A or Ohm. B implies that two relay contacts are blocked (for welding) into open position.</li> <li>Supply always the input channel (terminals "1"- "2") of the unit under test in order to verify if a single contact is blocked (for welding) into open position. Considering the measures of ohmmeter Ohm. A, set ON internal SW1 DIP-switches (n°1 or 2) to put in short circuit one relay coil at a time (starting with the 1<sup>st</sup> coil by DIP-switch n°1, then going on with the 2<sup>nd</sup> coil by DIP-switch n°2), verifying that ohmic continuity is always present between terminals "15" - "13". Considering the measures of ohmmeter Ohm. B, set ON internal SW1 DIP-switches (n°3 or 4) to put in short circuit one relay coil at a time (starting with the 3<sup>rd</sup> coil by DIP-switch n°3, then going on with the 4<sup>th</sup> coil by DIP-switch n°4), verifying that ohmic continuity is always present between terminals "16" - "14". In these situations, the absence of ohmic continuity implies that a relay contact (the one with energized coil because the other is de-energized, being its DIP-switch set ON) is blocked (for welding) into open position.</li> </ol>
3	Remove the bypass from the safety-related PLC or restore normal operation inserting the unit.

This test detects almost 100 % of all possible Dangerous Undetected failures in the relay module.

## SIL Applications

### D5294S Relay Output Modules for F&G Load

#### • Safety function

The failure behaviour is described from the following definitions:

- fail-Safe State: is defined as the output load being de-energized;
- fail Safe: failure mode that causes the module to go to the defined fail-safe state without a demand from the process;
- fail Dangerous: failure mode that does not respond to a demand from the process (i.e. being unable to go to the defined fail-safe state), so that the output load remains energized;
- fail "No Effect": failure mode of a component that is part of the safety function but that has no effect on the safety function. For the calculation of the SFF it is considered as a safe undetected failure;
- fail "Not part": failure mode of a component which is not part of the safety function but part of the circuit diagram and is listed for completeness. When calculating the SFF this failure mode is not taken into account. It is also not considered for the total failure rate (safety function) evaluation. Failures of diagnostic circuits belong to this group.

#### • Failure rates table:

Failure category	Failure rates (FIT)
$\lambda_{dd}$ = Total Dangerous Detected failures	0.00
$\lambda_{du}$ = Total Dangerous Undetected failures	3.20
$\lambda_{sd}$ = Total Safe Detected failures	0.00
$\lambda_{su}$ = Total Safe Undetected failures = $\lambda_{su\ int.} + \lambda_{no\ effect}$	512.80
↳ Safe Undetected failures = $\lambda_{su\ int.}$	8.74
↳ "No Effect" failures = $\lambda_{no\ effect}$	504.06
<b><math>\lambda_{tot\ safe}</math> = Total Failure Rate (Safety Function) = <math>\lambda_{dd} + \lambda_{du} + \lambda_{sd} + \lambda_{su}</math></b>	<b>516.00</b>
<b>MTBF (Safety Function) = <math>(1 / \lambda_{tot\ safe}) + MTTR</math> (8 hours)</b>	<b>221 years</b>
$\lambda_{not\ part}$ = "Not Part" failures	740.00
<b><math>\lambda_{tot\ device}</math> = Total Failure Rate (Device) = <math>\lambda_{tot\ safe} + \lambda_{not\ part}</math></b>	<b>1256.00</b>
<b>MTBF (Device) = <math>(1 / \lambda_{tot\ device}) + MTTR</math> (8 hours)</b>	<b>91 years</b>
PFSavg (= Average Probability of Fail Safe) @ 1 year = $1/2 * \lambda_{su\ int.} * 8760\ h$	3.83 E-05
PFDavg (= Average Probability of Failure on Demand) @ 1 year = $1/2 * \lambda_{du} * 8760\ h$	1.40 E-05
Total (Safe + Dangerous) Availability @ 1 year = $100 * (1 - PFSavg - PFDavg)$	99.995 %

#### • Failure rates table according to IEC 61508:

$\lambda_{sd}$	$\lambda_{su}$	$\lambda_{dd}$	$\lambda_{du}$	SFF
0.00 FIT	512.80 FIT	0.00 FIT	3.20 FIT	99.38%

#### • PFDavg vs T[Proof] table, with determination of SIL supposing module contributes 10% of entire safety function:

T[Proof] = 1 year	T[Proof] = 7 years	T[Proof] = 20 years
PFDavg = 1.40 E-05 Valid for SIL 3	PFDavg = 9.81 E-05 Valid for SIL 3	PFDavg = 2.80 E-04 Valid for SIL 2

#### • PFDavg vs T[Proof] table, with determination of SIL supposing module contributes 20% of entire safety function:

T[Proof] = 1 year	T[Proof] = 14 years	T[Proof] = 20 years
PFDavg = 1.40 E-05 Valid for SIL 3	PFDavg = 1.96 E-04 Valid for SIL 3	PFDavg = 2.80 E-04 Valid for SIL 2

The Pocket Portable Adapter type PPC5092 is suitable to connect the module D5294S to a PC via USB serial line, in order to configure and to monitor the operation parameters by means of SWC5090 software. The PPC5092 unit is connected to D5294S by mini USB and to PC by USB port. This adapter is not ATEX, UL or FM approved and is only to be used in Safe Area/Non Hazardous Locations. Do not use PPC5092 in Hazardous Area/Hazardous Locations. The PPC5092 adapter is powered by the PC (no battery power) when its USB port is plugged into the PC. It has a green LED as power-on indication.

SWC5090 Configuration & Monitoring Software

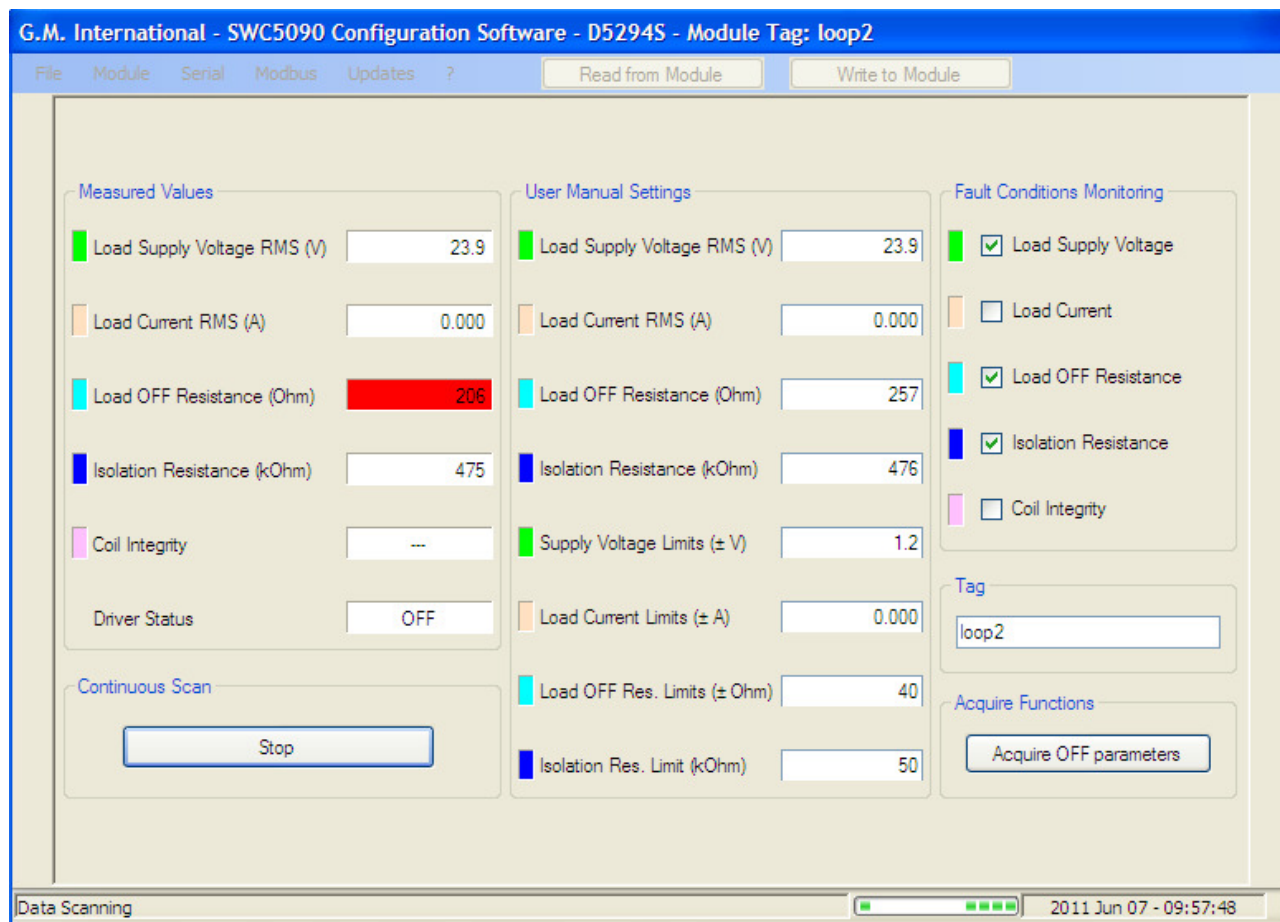

Description of the parameters (refer to ISM0154 instruction manual of “Installation and use of the SWC5090” for more information):

**MEASURED VALUES: Diagnostic parameters measured in the field.**

- Load Supply Voltage RMS (V) RMS voltage in Volt applied to the load or to be applied to the load.
- Load Current RMS (A) RMS current in Ampere that flows through the load.
- Load OFF Resistance (Ohm) Load+Line resistance in Ohm (only in OFF state, saturated in ON state).
- Isolation Resistance (kOhm) Isolation resistance between the load and the earth in kOhm (only in OFF state, saturate in ON state).
- Coil Integrity Reports the coil short circuit (only in ON state).
- Driver Status Indicates whether the load is energized (ON) or de-energized (OFF).

**ACQUIRE FUNCTIONS: Acquisition and saving of the diagnostic field parameters.**

- Acquire Off parameters The currently measured OFF parameters (voltage, load resistance and isolation resistance) are copied to the User Manual Settings (only in OFF state).
- Acquire On parameters The currently measured ON parameters (voltage and current) are copied to the User Manual Settings (only in ON state).

**TAG: Identification of the specific operating loop of D5293S/D5294S module.**

- Tag Loop name.

**CONTINUOUS SCAN: Continuous measurement of the field parameters.**

- Start/Stop Activates/de-activates the measurement of the field diagnostic parameters.

**USER MANUAL SETTINGS: Nominal values and acceptable ranges of the field parameters.**

- Load Supply Voltage RMS (V) Nominal voltage in Volt applied or to be applied to the load.
- Load Current RMS (A) Nominal current in Ampere that flows through the load.
- Load OFF Resistance (Ohm) Nominal Load+Line resistance in Ohm.
- Isolation Resistance (kOhm) Nominal isolation resistance in kOhm.
- Supply Voltage Limits (± V) Acceptable range in Volt below and above the nominal line voltage.
- Load Current Limits (± A) Acceptable range in Ampere below and above the nominal load current.
- Load OFF Res. Limits (± Ohm) Acceptable range in Ohm below and above the nominal line resistance.
- Isolation Res. Limit (kOhm) Acceptable range in kOhm below the nominal isolation resistance.

**FAULT CONDITIONS MONITORING: Conditions that activate the cumulative fault.**

- Load Supply Voltage When checked, the line voltage can activate the cumulative fault.
- Load Current When checked, the load current can activate the cumulative fault.
- Load OFF Resistance When checked, the line resistance can activate the cumulative fault.
- Isolation Resistance When checked, the earth isolation can activate the cumulative fault.
- Coil Integrity When checked, the short circuit of the coils can activate the cumulative fault.



Param. Address	Description	Notes
0	G.M. Factory Code	Identification Data
1	Instrument Code	
2	Option Code	
3	Hardware Release	
4	Software Release	
5 to 15	Reserved	
16	Modbus Address	Communication Data
17	Modbus Baudrate	
18	Modbus Format	
19	Modbus Error Counter	
20 to 31	Reserved	
32 to 47	Reserved	System Control
48 to 63	Reserved	Common Parameters
64	Measured Load Voltage	Input Data
65	Measured Load Current	
66	Measured Load Resistance	
67	Measured Isolation Resistance	
68	Driver Status	
69	Coil Status	
70	Resistance Time Constant	
71 to 79	Reserved	
80 to 95	Reserved	Output Data
96	Load Voltage Nominal	Input Configuration
97	Load Current Nominal	
98	Load Resistance Nominal	
99	Isolation Resistance Nominal	
100	Load Voltage Limits	
101	Load Current Limits	
102	Load Resistance Limits	
103	Isolation Resistance Limits	
104 to 111	Reserved	
112 to 127	Reserved	
128 to 143	Reserved	
144 to 159	Reserved	
160 to 175	Reserved	Output Configuration
176 to 191	Reserved	
192 to 207	Reserved	
208 to 223	Reserved	
224	Fault Status Mask	Alarm Control
225	Raw Fault Status	
226	Masked Fault Status	
227	Masked Fault Status without ON/OFF	
228 to 239	Reserved	
240 to 255	Reserved	
256 to 271	Reserved	
272 to 287	Reserved	
288 to 303	Reserved	
304 to 319	Reserved	
320	Resistance Time Constant Set	Input Calibration
321 to 335	Reserved	
336 to 351	Reserved	
352 to 367	Reserved	
368 to 383	Reserved	
384 to 399	Reserved	Output Calibration
400 to 415	Reserved	
416 to 431	Reserved	
432 to 447	Reserved	
448 to 463	Reserved	Tags
464	EEPROM Write	Command
465 to 479	Reserved	
480 to 495	Reserved	
496 to 499	Reserved	Debug
500	Head Communication Errors	
501	Modbus Communication Errors	
502 to 515	Reserved	

Supported ModBus Baudrates	
Index	Baudrate
0	4800
1	9600
2	19200
3	38400
4	57600
5	115200

Supported ModBus Formats	
Index	Format
0	8 data bit, no parity, 1 stop bit
1	8 data bit, even parity, 1 stop bit
2	8 data bit, odd parity, 1 stop bit

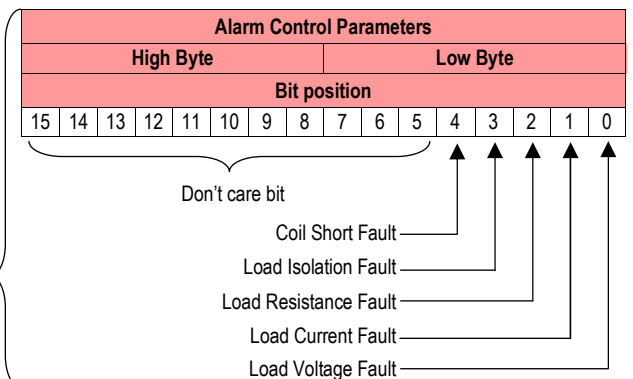

Fault Status Mask: activated fault conditions monitoring  
 Masked Fault Status without ON/OFF= Raw Fault Status & Fault Status Mask  
 Masked Fault Status with ON = Raw Fault Status & Fault Status Mask & "10011"  
 Masked Fault Status with OFF = Raw Fault Status & Fault Status Mask & "01101"  
 With: & = bitwise AND operation