



# INSTRUCTION MANUAL

10 A SIL 3 Relay Output Module for NE Load  
and 115 Vac coil voltage, DIN-Rail  
Model D5290S-080



## Characteristics

**General Description:** The D5290S-080 is a relay module suitable for the switching of safety related circuits, up to SIL 3 level according to IEC 61508 for high risk industries. It provides isolation between input channel and output contacts. The input channel requires 115 Vac voltage signal to drive the relay coils.

D5290S-080 provides two NO contacts for normally energized load and a NC contact for service purpose, in order to switch the NE load on both supply lines. See the following pages for Functional Safety applications with related SIL value.

Mounting on standard DIN-Rail in Safe Area.

## Technical Data

**Input:** 115 Vac nom (95 to 130 Vac).

**Current consumption @ 115 Vac:** 25 mA with relay energized, typical.

**Power dissipation:** 2.5 W with 115 Vac input voltage, relay energized, typical.

**Isolation (Test Voltage):** Input / All Outputs: 2.5 KV ; Out 1 / Out 2: 500 V.

**Output:** 1 voltage free SPDT relay contact identified with outputs: Out 1 (NO contact) terminals 13-21 and Service Load Out (NC contact) terminals 13-15; 1 voltage free SPST relay contact identified with output Out 2 (NO contact) terminals 14-22.

Terminals 13-21 (Out 1) and 14-22 (Out 2) are open when relay is de-energized, closed in energized relay condition.

Service load output (not SIL) at terminals 13-15 is normally close when relay is de-energized, open in energized relay condition.

**Contact material:** Ag Alloy (Cd free).

**Contact rating:** 10 A 250 Vac 2500 VA, 10 A 250 Vdc 300 W (resistive load).

**DC Load breaking capacity:**

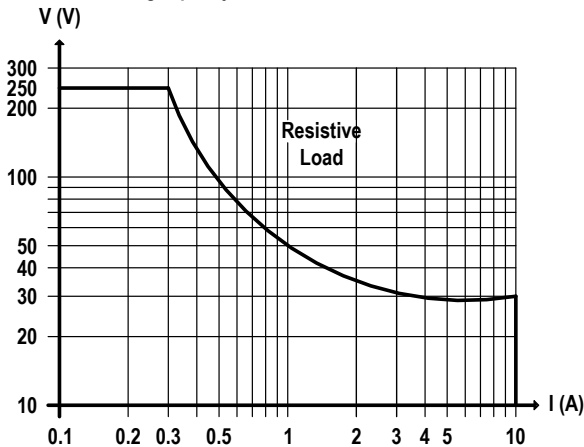

**Mechanical / Electrical life:**  $5 * 10^6 / 5 * 10^4$  operation, typical.

**Bounce time NO / NC contact:** 4 / 10 ms, typical.

**Frequency response:** 10 Hz maximum.

**Compatibility:**



CE mark compliant, conforms to 94/9/EC Atex Directive and to 2004/108/CE EMC Directive.

**Environmental conditions:**

**Operating:** temperature limits - 40 to + 60 °C, relative humidity 95 %, up to 55 °C.

**Storage:** temperature limits - 45 to + 80 °C.

**Approvals:**



TUV Certificate No. C-IS-204194-01, SIL 2 / SIL 3 conforms to IEC61508.

**Mounting:**

T35 DIN-Rail according to EN50022.

**Weight:** about 145 g.

**Connection:** by polarized plug-in disconnect screw terminal blocks to accommodate terminations up to 2.5 mm<sup>2</sup>.

**Location:** Safe Area installation.

**Protection class:** IP 20.

**Dimensions:** Width 22.5 mm, Depth 123 mm, Height 120 mm.

## Ordering Information

Model: D5290S-080

DIN-Rail accessories: Cover and fix MCHP196

## Front Panel and Features



- SIL 3 according to IEC 61508 for 10 years life time (10 % or more of total SIF).
- PFDavg (1 year) 7.01 E-06, SFF 99.37 % for NE Load.
- 10 A SIL 3 contact for NE load and contact for service purpose.
- Input/Output isolation.
- EMC Compatibility to EN61000-6-2, EN61000-6-4, EN61326-1, EN61326-3-1 for safety system.
- Simplified installation using standard DIN-Rail.

## Terminal block connections

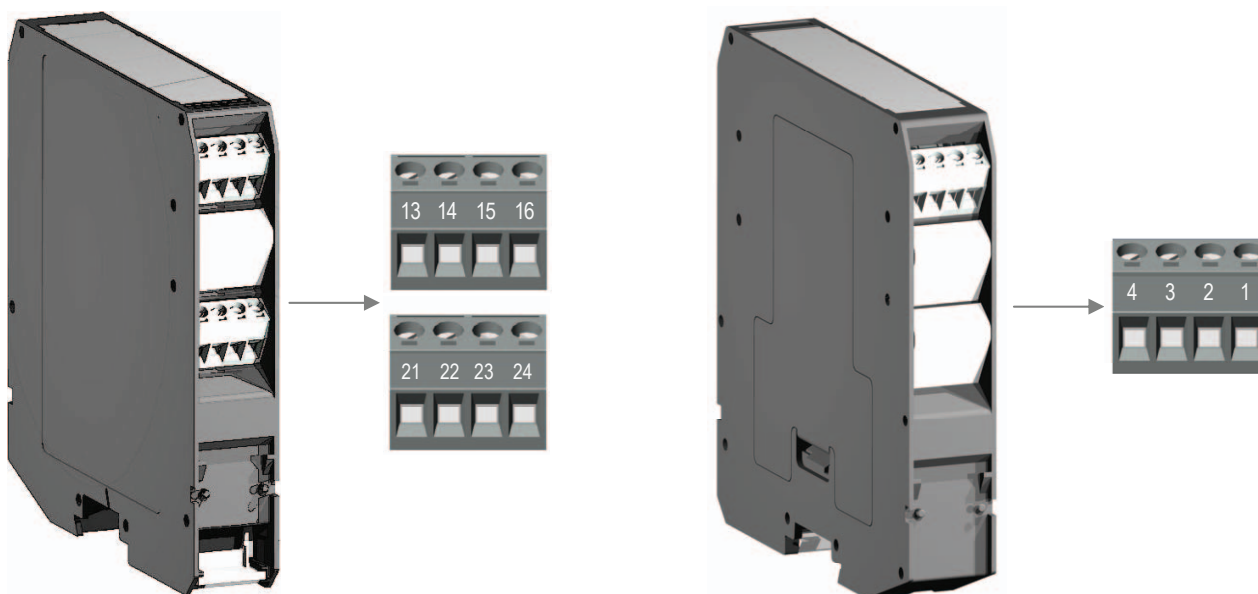

## SAFE AREA

<b>13</b>	CM1 Common pole of: Normally Open contact (Out 1) and Normally Closed contact (Service Load (Not SIL) out)	<b>1 or 3</b>	115 Vac Input signal line
<b>14</b>	NO1 pole of Normally Open contact (Out 2)	<b>2 or 4</b>	115 Vac Input signal line
<b>15</b>	NC1 pole of Normally Closed contact (Service Load (Not SIL) out)		
<b>16</b>	Not used		
<b>21</b>	NO2 pole of Normally Open contact (Out 1)		
<b>22</b>	NO3 pole of Normally Open contact (Out 2)		
<b>23</b>	Not used		
<b>24</b>	Not used		

SAFE AREA

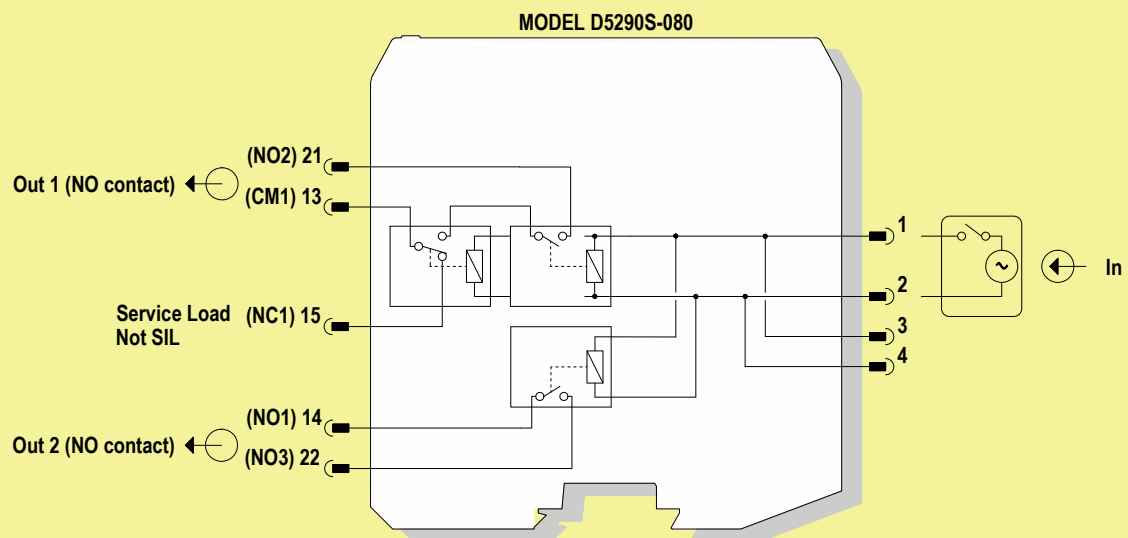

See the following pages for Functional Safety applications with related SIL value.

Relay contact shown in de-energized position.  
Terminals 13-21 and 14-22 are open; terminal 13-15 is closed.

To prevent relay contacts from damaging, connect an external protection (fuse or similar),  
chosen according to the relay breaking capacity diagram.

**Application D5290S-080 - SIL 3 Load Normally Energized Condition (NE) and Normally Energized Relay, with interruption of both load supply lines**

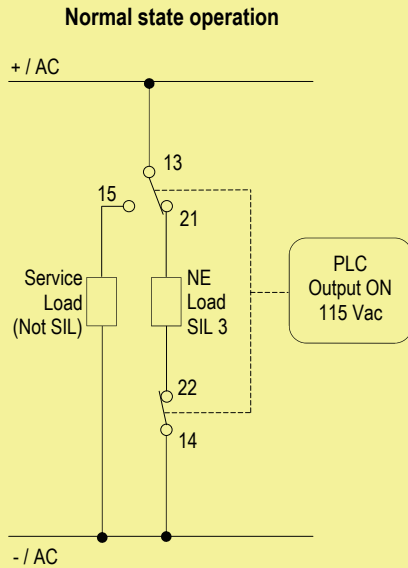

**Contacts 13-21 and 14-22:** in normal operation relays are energized, contacts are closed, NE load is energized.  
**Contact 13-15:** in normal operation relay is energized, contact is open, service load for NE load is de-energized.

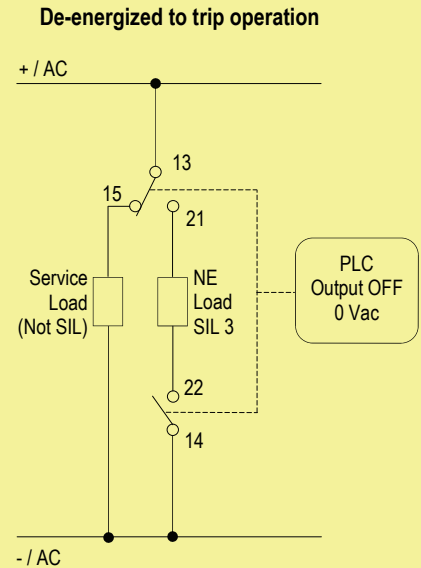

**Contacts 13-21 and 14-22:** the SIL 3 Safety Function is met when the relays are de-energized, contacts are open, NE load is de-energized.  
**Contact 13-15:** in safe state the relay is de-energized, contact is closed, service load for NE load is energized.

**Application D5290S-080 - SIL 3 Load Normally Energized Condition (NE) and Normally Energized Relay, with interruption of only one load supply line**

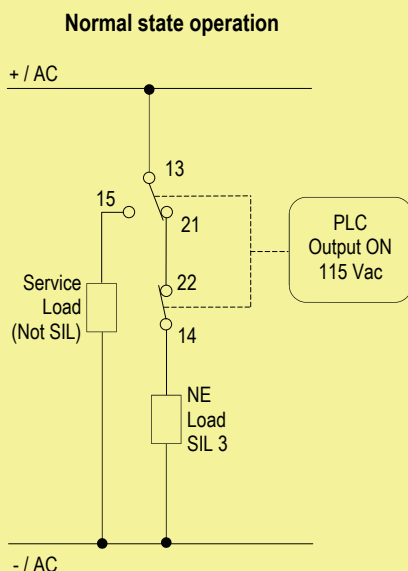

**Contacts 13-21 and 14-22:** in normal operation relays are energized, contacts are closed, NE load is energized.  
**Contact 13-15:** in normal operation relay is energized, contact is open, service load for NE load is de-energized.

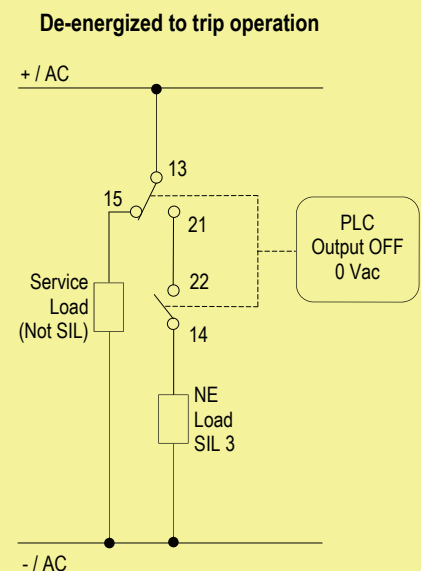

**Contacts 13-21 and 14-22:** the SIL 3 Safety Function is met when the relays are de-energized, contacts are open, NE load is de-energized.  
**Contact 13-15:** in safe state the relay is de-energized, contact is closed, service load for NE load is energized.

**To prevent relay contacts from damaging, connect an external protection (fuse or similar), chosen according to the relay breaking capacity diagram.**

## Warning

D5290S-080 is an electrical apparatus installed into standard EN50022 T35 DIN-Rail located in Safe Area within the specified operating temperature limits Tamb - 40 to +60 °C. D5290S-080 must be installed, operated and maintained only by qualified personnel, in accordance to the relevant national/international installation standards, following the established installation rules.

**Warning: de-energize main power source (turn off power supply voltage) and disconnect plug-in terminal blocks before opening the enclosure to avoid electrical shock when connected to live hazardous potential.**

Failure to properly installation or use of the equipment may risk to damage the unit or severe personal injury.

The unit cannot be repaired by the end user and must be returned to the manufacturer or his authorized representative.

Any unauthorized modification must be avoided.

## Operation

D5290S-080 relay module is suitable for the switching of safety related circuits, providing isolation between the input and output contacts.

D5290S-080 provides two NO contacts for normally energized load and a NC contact for service purpose, in order to switch the NE load on both supply lines.

See the previous pages for Functional Safety applications with related SIL value.

A "RELAY STATUS" yellow led lights when input is powered, showing that relay is energized.

## Installation

D5290S-080 is a relay output module housed in a plastic enclosure suitable for installation on T35 DIN-Rail according to EN50022.

D5290S-080 unit can be mounted with any orientation over the entire ambient temperature range.

Electrical connection of conductors up to 2.5 mm<sup>2</sup> are accommodated by polarized plug-in removable screw terminal blocks which can be plugged in/out into a powered unit without suffering or causing any damage.

The wiring cables have to be proportionate in base to the current and the length of the cable.

On the section "Function Diagram" and enclosure side a block diagram identifies all connections.

Identify the function and location of each connection terminal using the wiring diagram on the corresponding section, as an example (interruption of both NE load supply lines):

Connect 115 Vac signal lines at input terminals "1" and "2" (input terminals "3" and "4" are provided for daisy chain connection to the next module).

Connect positive or AC load supply line to CM1 Common pole (terminal "13" (for SIL 3 NE load and Not SIL Service Load)).

Connect SIL 3 Normally Energized (NE) Load at terminal "21" and "22".

Connect negative or AC load supply line at terminal "14" (for SIL 3 NE load).

Connect Not SIL Service Load at terminal "15" and to negative or AC load supply line.

Installation and wiring must be in accordance to the relevant national or international installation standards, make sure that conductors are well isolated from each other and do not produce any unintentional connection.

Connect SPST relay contacts checking the load rating to be within the contact maximum rating (10 A 250 Vac 2500 VA, 10 A 250 Vdc 300 W resistive load).

**To prevent relay contacts from damaging, connect an external protection (fuse or similar), chosen according to the relay breaking capacity diagram on data sheet.**

The enclosure provides, according to EN60529, an IP20 minimum degree of mechanical protection (or similar to NEMA Standard 250 type 1) for indoor installation, outdoor installation requires an additional enclosure with higher degree of protection (i.e. IP54 to IP65 or NEMA type 12-13) consistent with the effective operating environment of the specific installation.

Units must be protected against dirt, dust, extreme mechanical (e.g. vibration, impact and shock) and thermal stress, and casual contacts.

If enclosure needs to be cleaned use only a cloth lightly moistened by a mixture of detergent in water.

Any penetration of cleaning liquid must be avoided to prevent damage to the unit. Any unauthorized card modification must be avoided.

Relay output contact must be connected to load non exceeding category II overvoltage limits.

**Warning: de-energize main power source (turn off power supply voltage) and disconnect plug-in terminal blocks before opening the enclosure to avoid electrical shock when connected to live hazardous potential.**

## Start-up

Before powering the inputs of unit check that all wires are properly connected. Check conductors for exposed wires that could touch each other causing dangerous unwanted shorts.

Enabling input, the "RELAY STATUS" yellow led must be lit and load circuit must be energized because relay output contacts (Out 1 and Out 2) are closed. Indeed, disabling input, the "RELAY STATUS" yellow led must be turned off and load circuit must be de-energized because relay output contacts (Out 1 and Out 2) are open.

**D5290S-080 Relay Output Module for NE load and 115 Vac coil voltage**

• **Safety function**

The failure behaviour is described from the following definitions:

- fail-Safe State: is defined as the output load being de-energized;
- fail Safe: failure mode that causes the module to go to the defined fail-safe state without a demand from the process;
- fail Dangerous: failure mode that does not respond to a demand from the process (i.e. being unable to go to the defined fail-safe state), so that the output load remains energized;
- fail "No Effect": failure mode of a component that is part of the safety function but that has no effect on the safety function.  
For the calculation of the SFF it is considered a safe undetected failure;
- fail "Not part": failure mode of a component which is not part of the safety function but part of the circuit diagram and is listed for completeness.  
When calculating the SFF this failure mode is not taken into account. It is also not considered for the total failure rate (safety function) evaluation.

• Failure rates table:

Failure category	Failure rates (FIT)
$\lambda_{dd}$ = Total Dangerous Detected failures	0.00
$\lambda_{du}$ = Total Dangerous Undetected failures	1.60
$\lambda_{sd}$ = Total Safe Detected failures	0.00
$\lambda_{su}$ = Total Safe Undetected failures	251.20
↳ Safe Undetected failures	239.36
↳ "No Effect" failures	11.84
<b><math>\lambda_{tot\ safe}</math> = Total Failure Rate (Safety Function) = <math>\lambda_{dd} + \lambda_{du} + \lambda_{sd} + \lambda_{su}</math></b>	<b>252.80</b>
$\lambda_{notpart}$ = "Not Part" failures	0.00
<b><math>\lambda_{tot\ device}</math> = Total Failure Rate (Device) = <math>\lambda_{tot\ safe} + \lambda_{not\ part}</math></b>	<b>252.80</b>
<b>MTBF (single channel) = <math>(1 / \lambda_{tot\ device}) + MTTR</math> (8 hours)</b>	<b>451 years</b>
$MTTF_S$ (Total Safe) = $1 / (\lambda_{sd} + \lambda_{su})$	454 years
$MTTF_D$ (Dangerous) = $1 / \lambda_{du}$	71347 years

• Failure rates table according to IEC 61508:

$\lambda_{sd}$	$\lambda_{su}$	$\lambda_{dd}$	$\lambda_{du}$	SFF
0.00 FIT	251.20 FIT	0.00 FIT	1.60 FIT	99.37%

• PFDavg vs Time table, with determination of SIL supposing module contributes 10% or more of entire safety function:

T = 1 year	T = 10 years (as life time)
PFDavg = 7.01 E-06 Valid for SIL 3	PFDavg = 7.01 E-05 Valid for SIL 3