



INSTRUCTION MANUAL

SIL 3 Switch/Proximity Interface
DIN-Rail and Termination Board
Models D5034S, D5034D



Characteristics

General Description: The single and dual channel Switch/Proximity Detector Interface, D5034S and D5034D is a high integrity repeater, designed to interface contacts or proximity detectors (EN60947-5-6, NAMUR) located in Hazardous Area and is suitable for applications requiring SIL 3 level (according to IEC 61508) in safety related systems for high risk industries. Field loop integrity and status (line plus contact or proximator) are continuously and directly monitored, in transparent mode, into the PLC, ESD, DCS using their existing input line, without requiring an additional channel for line fault detection.

PLC / DCS can detect the following conditions:

0.5 to 1.3 mA Input open condition
2.0 to 6.0 mA Input close condition
0 to 0.4 mA Input fault condition (Line break)
6.5 to 8.0 mA Input fault condition (Short circuit)

These are automatically detected for proximity switches inputs.

For contact inputs is necessary to install end of line resistors close to the contacts.

Mounting on standard DIN-Rail, with or without Power Bus, or on customized Termination Boards, in Safe Area or in Zone 2.

Technical Data

Supply: 24 Vdc nom (18 to 30 Vdc) reverse polarity protected, ripple within voltage limits ≤ 5 Vpp, 2 A time lag fuse internally protected.

Current consumption @ 24 V: 30 mA for 2 channels D5034D, 15 mA for 1 channel D5034S with short circuit input, typical.

Power dissipation: 0.72 W for 2 channels D5034D, 0.36 W for 1 channel D5034S with 24 V supply voltage and short circuit input, typical.

Isolation (Test Voltage): I.S. In/Out 2.5 KV; I.S. In/Supply 2.5 KV; I.S. In/I.S. In 500 V; Out/Supply 500 V; Out/Out 500 V.

Input: Current levels: ≥ 0.1 mA to ≤ 8.0 mA

Input equivalent source: 8 V 1 K Ω typical (8 V no load, 8 mA short circuit).

Output: 0.1 to 8.0 mA in sink mode, V max. 30 V, current limited at ≈ 8 mA, repeats input current level.

Response time: 1 ms (0 to 100 % step change).

Output ripple: ≤ 20 mVrms.

Power dissipation: 0.4 W for 2 channels D5034D, 0.2 W for 1 channel D5034S short circuit input/output and 24 Vdc loop voltage, typical.

Performance: Ref. Conditions 24 V supply, 23 ± 1 °C ambient temperature.

Calibration accuracy: $\leq \pm 0.25$ % of full scale.

Linearity error: $\leq \pm 0.25$ % of full scale.

Supply voltage influence: $\leq \pm 0.05$ % of full scale for a min to max supply change.

Load influence: $\leq \pm 0.05$ % of full scale for a 0 to 100 % load resistance change.

Temperature influence: $\leq \pm 0.03$ % of full scale on zero and span for a 1 °C change.

Compatibility:



CE mark compliant, conforms to 94/9/EC Atex Directive and to 2004/108/CE EMC Directive.

Environmental conditions:

Operating: temperature limits - 40 to + 70 °C, relative humidity 95 %, up to 55 °C.

Storage: temperature limits - 45 to + 80 °C.

Safety Description:



ATEX: II 3(1) G Ex nA [ja Ga] IIC T4 Gc, II (1) D [Ex ia Da] IIIC, I (M1) [Ex ia Ma] I

IECEx: Ex nA [ja Ga] IIC T4 Gc, [Ex ia Da] IIIC, [Ex ia Ma] I, associated apparatus and non-sparking electrical equipment.

Uo/Voc = 10.5 V, Io/Isc = 15 mA, Po/Po = 39 mW at terminals 7-8, 9-10.

Um = 250 Vrms, -40 °C \leq Ta \leq 70 °C.

Approvals: BVS 10 ATEX E 113 X conforms to EN60079-0, EN60079-11, EN60079-15, EN60079-26, EN61241-11, EN50303,

IECEx BVS 10.0072 X conforms to IEC60079-0, IEC60079-11, IEC60079-15, IEC60079-26, IEC1241-11.

Russia according to GOST 12.2.007.0-75, R 51330.0-99, R 51330.10-99, R 51330.14-99 2ExnA[ja]IIC T4 X.

Ukraine according to GOST 12.2.007.0, 22782.0, 22782.3, 22782.5 2Exs[ja]IIC T4 X.

TUV Certificate No. C-IS-204194-01, SIL 2 / SIL 3 conforms to IEC61508.

Mounting: T35 DIN-Rail according to EN50022, with or without Power Bus or on customized Termination Board.

Weight: about 145 g D5034D, 120 g D5034S.

Connection: by polarized plug-in disconnect screw terminal blocks to accommodate terminations up to 2.5 mm².

Location: Safe Area/Non Hazardous Locations or Zone 2, Group IIC T4 installation.

Protection class: IP 20.

Dimensions: Width 12.5 mm, Depth 123 mm, Height 120 mm.

Ordering Information

Model:	D5034	
1 channel		S
2 channels		D

Power Bus and DIN-Rail accessories:
 Connector JDFT049 Cover and fix MCHP196
 Terminal block male MOR017 Terminal block female MOR022

Front Panel and Features



- SIL 3 according to IEC 61508 for Tproof = 1 / 2 yrs (10 / 20 % of total SIF).
- SIL 2 according to IEC 61508 for Tproof = 10 / 20 yrs (10 / 20 % of total SIF).
- PFDavg (1 year) 8.43 E-05, SFF 93.88 %.
- 2 fully independent channels.
- Input from Zone 0 (Zone 20), installation in Zone 2.
- Transparent mode operation.
- Field open and short circuit detection available to the PLC/DCS card.
- Input and Output short circuit proof
- High Accuracy.
- Three port isolation, Input/Output/Supply.
- EMC Compatibility to EN61000-6-2, EN61000-6-4, EN61326-1, EN61326-3-1 for safety system.
- ATEX, IECEx, Russian and Ukrainian Certifications.
- High Density, two channels per unit.
- Simplified installation using standard DIN-Rail and plug-in terminal blocks, with or without Power Bus, or customized Termination Boards.
- 250 Vrms (Um) max. voltage allowed to the instruments associated with the barrier.

Terminal block connections

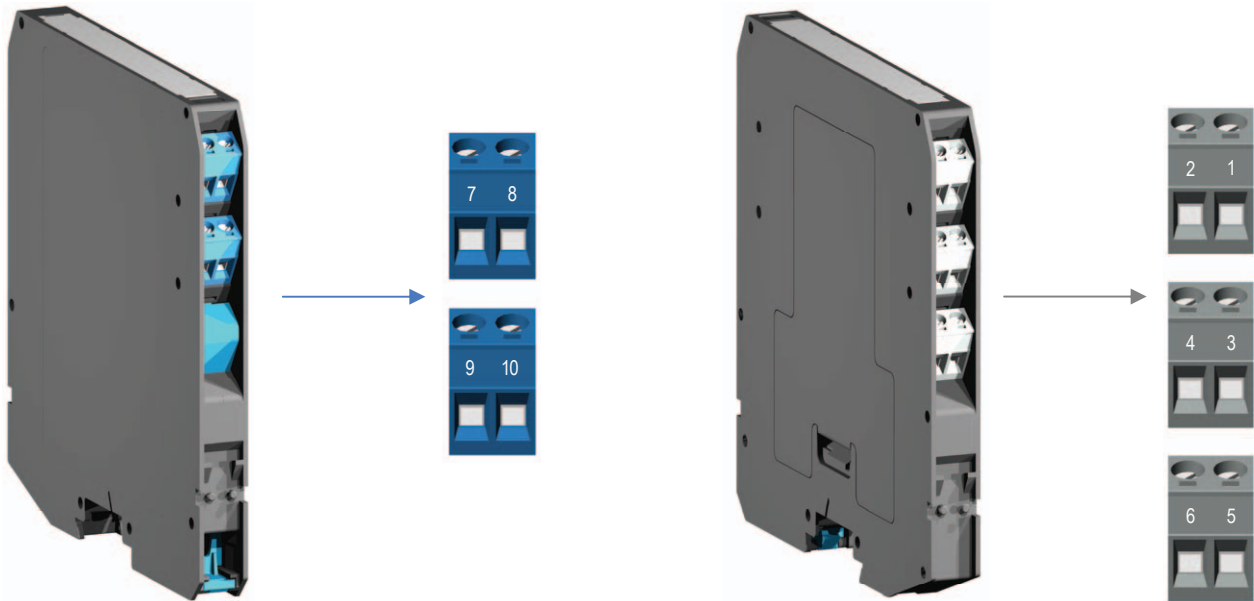

HAZARDOUS AREA

7	+ Input Ch 1 for Proximity or Voltage free Contact
8	- Input Ch 1 for Proximity or Voltage free Contact
9	+ Input Ch 2 for Proximity or Voltage free Contact
10	- Input Ch 2 for Proximity or Voltage free Contact

SAFE AREA

1	+ Output Ch 1
2	- Output Ch 1
3	+ Output Ch 2
4	- Output Ch 2
5	+ Power Supply 24 Vdc
6	- Power Supply 24 Vdc

Parameters Table

In the system safety analysis, always check the Hazardous Area/Hazardous Locations devices to conform with the related system documentation, if the device is Intrinsically Safe check its suitability for the Hazardous Area/Hazardous Locations and group encountered and that its maximum allowable voltage, current, power (U_i/V_{max} , I_i/I_{max} , P_i/P_i) are not exceeded by the safety parameters (U_o/V_{oc} , I_o/I_{sc} , P_o/P_o) of the D5034 series Associated Apparatus connected to it. Also consider the maximum operating temperature of the field device, Check that added connecting cable and field device capacitance and inductance do not exceed the limits (C_o/C_a , L_o/L_a , L_o/R_o) given in the Associated Apparatus parameters for the effective group. See parameters indicated in the table below:

D5034 Terminals		D5034 Associated Apparatus Parameters		Must be	Hazardous Area/ Hazardous Locations Device Parameters
Ch1	7 - 8	$U_o / V_{oc} = 10.5 \text{ V}$		\leq	U_i / V_{max}
Ch2	9 - 10				
Ch1	7 - 8	$I_o / I_{sc} = 15 \text{ mA}$		\leq	I_i / I_{max}
Ch2	9 - 10				
Ch1	7 - 8	$P_o / P_o = 39 \text{ mW}$		\leq	P_i / P_i
Ch2	9 - 10				
D5034 Terminals		D5034 Associated Apparatus Parameters Cenelec (US)		Must be	Hazardous Area/ Hazardous Locations Device + Cable Parameters
Ch1	7 - 8	$C_o / C_a = 2.41 \mu\text{F}$	IIC (A, B)	\geq	$C_i / C_i \text{ device} + \text{C cable}$
Ch2	9 - 10	$C_o / C_a = 16.80 \mu\text{F}$	IIB (C)		
		$C_o / C_a = 75.00 \mu\text{F}$	IIA (D)		
		$C_o / C_a = 66.00 \mu\text{F}$	I		
		$C_o / C_a = 16.80 \mu\text{F}$	iaD (E, F, G)		
Ch1	7 - 8	$L_o / L_a = 163.2 \text{ mH}$	IIC (A, B)	\geq	$L_i / L_i \text{ device} + \text{L cable}$
Ch2	9 - 10	$L_o / L_a = 652.8 \text{ mH}$	IIB (C)		
		$L_o / L_a = 1305.6 \text{ mH}$	IIA (D)		
		$L_o / L_a = 2142.0 \text{ mH}$	I		
		$L_o / L_a = 652.8 \text{ mH}$	iaD (E, F, G)		
Ch1	7 - 8	$L_o / R_o = 918.2 \mu\text{H}/\Omega$	IIC (A, B)	\geq	$L_i / R_i \text{ device and}$ $L \text{ cable} / R \text{ cable}$
Ch2	9 - 10	$L_o / R_o = 3672.9 \mu\text{H}/\Omega$	IIB (C)		
		$L_o / R_o = 7345.8 \mu\text{H}/\Omega$	IIA (D)		
		$L_o / R_o = 12051.8 \mu\text{H}/\Omega$	I		
		$L_o / R_o = 3672.9 \mu\text{H}/\Omega$	iaD (E, F, G)		

For installations in which both the C_i and L_i of the Intrinsically Safe apparatus exceed 1 % of the C_o and L_o parameters of the Associated Apparatus (excluding the cable), then 50 % of C_o and L_o parameters are applicable and shall not be exceeded (50 % of the C_o and L_o become the limits which must include the cable such that $C_i \text{ device} + \text{C cable} \leq 50 \% \text{ of } C_o$ and $L_i \text{ device} + \text{L cable} \leq 50 \% \text{ of } L_o$).

If the cable parameters are unknown, the following value may be used: Capacitance 180pF per meter (60pF per foot), Inductance 0.60μH per meter (0.20μH per foot).

Function Diagram

HAZARDOUS AREA ZONE 0 (ZONE 20) GROUP IIC

SAFE AREA, ZONE 2 GROUP IIC T4

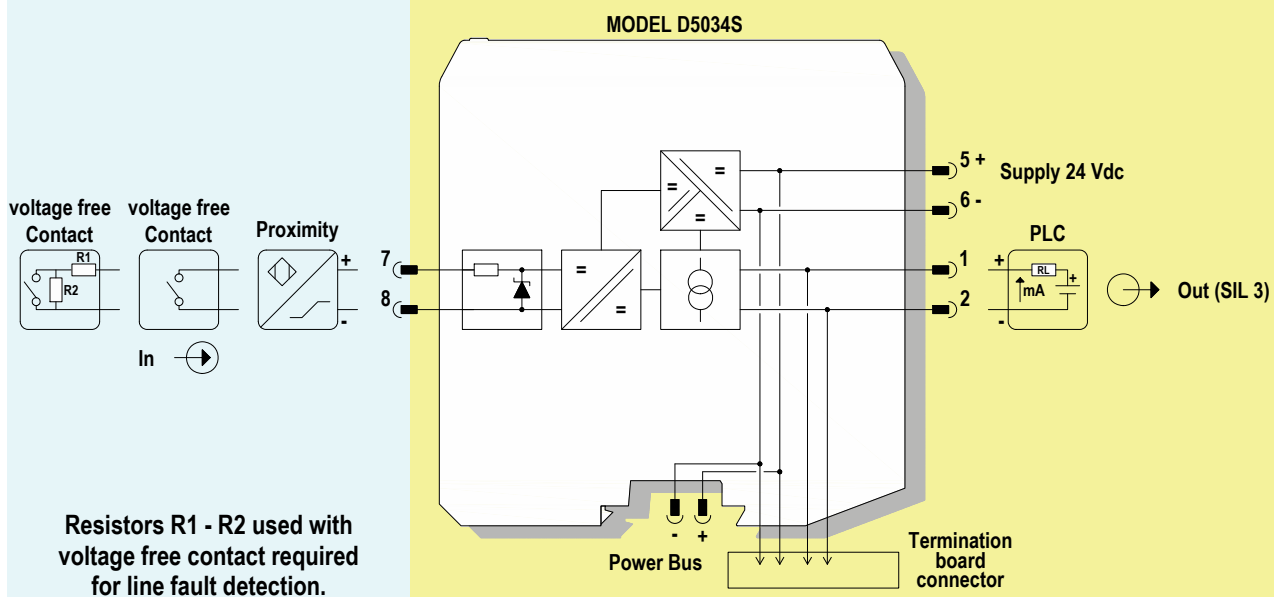
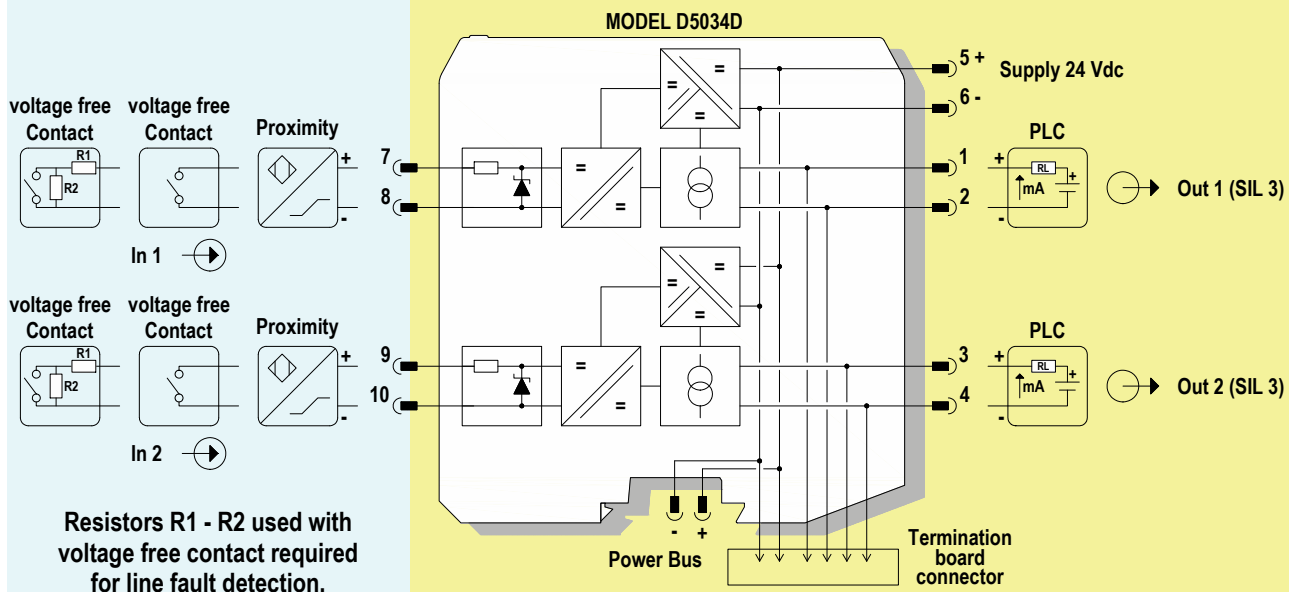

Warning

D5034 series are isolated Intrinsically Safe Associated Apparatus installed into standard EN50022 T35 DIN-Rail located in Safe Area or Zone 2, Group IIC, Temperature T4, Hazardous Area (according to EN/IEC60079-15) within the specified operating temperature limits Tamb -40 to +70 °C, and connected to equipment with a maximum limit for AC power supply Um of 250 Vrms.

Not to be connected to control equipment that uses or generates more than 250 Vrms or Vdc with respect to earth ground.

D5034 series must be installed, operated and maintained only by qualified personnel, in accordance to the relevant national/international installation standards (e.g. IEC/EN60079-14 Electrical apparatus for explosive gas atmospheres - Part 14: Electrical installations in hazardous areas (other than mines)), following the established installation rules, particular care shall be given to segregation and clear identification of I.S. conductors from non I.S. ones.

De-energize power source (turn off power supply voltage) before plug or unplug the terminal blocks when installed in Hazardous Area or unless area is known to be nonhazardous.

Warning: substitution of components may impair Intrinsic Safety and suitability for Zone 2.

Explosion Hazard: to prevent ignition of flammable or combustible atmospheres, disconnect power before servicing or unless area is known to be nonhazardous.

Failure to properly installation or use of the equipment may risk to damage the unit or severe personal injury.

The unit cannot be repaired by the end user and must be returned to the manufacturer or his authorized representative.

Any unauthorized modification must be avoided.

Operation

The single and dual channel Switch/Proximity Interface, D5034S and D5034D is a high integrity repeater, designed to interface contacts or proximity detectors (EN60947-5-6, NAMUR) located in Hazardous Area and is suitable for applications requiring SIL 3 level (according to IEC 61508) in safety related systems for high risk industries.

Field loop integrity and status (line plus contact or proximitor) are continuously and directly monitored, in transparent mode, into the PLC, ESD, DCS using their existing input line, without requiring an additional channel for line fault detection.

PLC / DCS can detect the following conditions:

0.5 to 1.3 mA	Input open condition
2.0 to 6.0 mA	Input close condition
0 to 0.4 mA	Input fault condition (Line break)
6.5 to 8.0 mA	Input fault condition (Short circuit)

These are automatically detected for proximity switches inputs. A "POWER ON" green led for each channel lits when input power is present.

Note: use of voltage free electrical contacts with fault detection enabled (control equipment) requires, near the switch at the end of the line a R1=1 K Ω typical (470 Ω to 2 K Ω range) resistor in series and a R2=10 k Ω typical (5 K Ω to 15 K Ω range) resistor in parallel to the contacts in order to allow the fault detection circuit to distinguish between a condition of contact close/open and a line open/short circuit fault.

Installation

D5034 series are Switch/Proximity Detector Interface housed in a plastic enclosure suitable for installation on T35 DIN-Rail according to EN50022, with or without Power Bus or on customized Termination Board.

D5034 unit can be mounted with any orientation over the entire ambient temperature range.

Electrical connection of conductors up to 2.5 mm² are accommodated by polarized plug-in removable screw terminal blocks which can be plugged in/out into a powered unit without suffering or causing any damage (**for Zone 2 installations check the area to be nonhazardous before servicing**).

The wiring cables have to be proportionate in base to the current and the length of the cable.

On the section "Function Diagram" and enclosure side a block diagram identifies all connections.

Identify the number of channels of the specific card (e.g. D5034S is a single channel model and D5034D is a dual channel model), the function and location of each connection terminal using the wiring diagram on the corresponding section, as an example:

Connect 24 Vdc power supply positive at terminal "5" and negative at terminal "6".

For Model D5034S connect positive output of channel 1 at terminal "1" and negative output at "2".

For Model D5034D in addition to channel 1 connections above, connect positive output of channel 2 at terminal "3" and negative output at "4".

For Model D5034S, in case of Proximity or Voltage free Contact, connect the wires at terminal "7" for positive and "8" for negative.

For Model D5034D in addition to channel 1 connections above, connect terminal "9" for positive and "10" for negative on channel 2.

Intrinsically Safe conductors must be identified and segregated from non I.S. and wired in accordance to the relevant national/international installation standards (e.g. EN/IEC60079-14 Electrical apparatus for explosive gas atmospheres - Part 14: Electrical installations in hazardous areas (other than mines)), make sure that conductors are well isolated from each other and do not produce any unintentional connection.

The enclosure provides, according to EN60529, an IP20 minimum degree of mechanical protection (or similar to NEMA Standard 250 type 1) for indoor installation, outdoor installation requires an additional enclosure with higher degree of protection (i.e. IP54 to IP65 or NEMA type 12-13) consistent with the effective operating environment of the specific installation.

Units must be protected against dirt, dust, extreme mechanical (e.g. vibration, impact and shock) and thermal stress, and casual contacts.

If enclosure needs to be cleaned use only a cloth lightly moistened by a mixture of detergent in water.

Electrostatic Hazard: to avoid electrostatic hazard, the enclosure of D5034 must be cleaned only with a damp or antistatic cloth.

Any penetration of cleaning liquid must be avoided to prevent damage to the unit. Any unauthorized card modification must be avoided.

According to EN61010, D5034 series must be connected to SELV or SELV-E supplies.

End of Line Resistor for Contact

Use of voltage free electrical contacts with fault detection enabled (control equipment) requires, near the switch at the end of the line a 1 K Ω typical (470 Ω to 2 K Ω range) series connected resistor and a 10 K Ω typical (5 K Ω to 15 K Ω range) parallel connected resistor in order to allow the fault detection circuit to distinguish between a condition of contact close/open and a line open/short circuit fault.

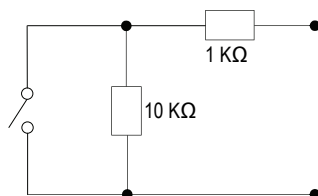

Start-up

Before powering the unit check that all wires are properly connected, particularly supply conductors and their polarity, input and output wires, also check that Intrinsically Safe conductors and cable trays are segregated (no direct contacts with other non I.S. conductors) and identified either by color coding, preferably blue, or by marking. Check conductors for exposed wires that could touch each other causing dangerous unwanted shorts. Turn on power, the "power on" green leds must be lit output condition must be in accordance with condition of the corresponding input line. If possible close and open input lines one at time checking the corresponding reflected current output to be correct.

Testing procedure at T-proof

The proof test shall be performed to reveal dangerous faults which are undetected by diagnostic. This means that it is necessary to specify how dangerous undetected faults, which have been noted during the FMEDA, can be detected during proof test.

Note for switch input: to detect a broken wire, or a short circuit condition, in the input connections it is necessary to mount, close to the switches, the end of line resistors: R1=1 K Ω typical (470 Ω to 2 K Ω range) resistor in series and R2=10 k Ω typical (5 K Ω to 15 K Ω range) resistor in parallel to the contacts.

The **Proof test 1** consists of the following steps:

Steps	Action
1	Bypass the safety-related PLC or take other appropriate action to avoid a false trip.
2	Vary the state condition of the input sensors /contacts or the proximity switches connected in the field in order to go to short circuit condition and verify that the output current of the repeater reaches high current value (> 7 mA). This test for compliance voltage problems such as a low loop power supply voltage or increased wiring resistance.
3	Vary the state condition of the input sensors / contacts or the proximity switches connected in the field in order to go to open connection condition (equivalent to line breakage) and verify that the output current of the repeater reaches low current value (< 0.35 mA). This tests for possible quiescent current related failures.
4	Restore the loop to full operation.
5	Remove the bypass from the safety-related PLC or restore normal operation.

This test will detect approximately 30 % of possible Dangerous Undetected failures in the repeater.

The **Proof test 2** consists of the following steps:

Steps	Action
1	Bypass the safety-related PLC or take other appropriate action to avoid a false trip.
2	Perform step 2 and 3 of the Proof Test 1 .
3	Connect an ammeter in series to the input sensors / contacts or the proximity switches in order to measure the input sensor current. Then vary the state condition of the input sensors / contacts (from open to close condition and vice versa) or the proximity switches (from ON to OFF condition and vice versa), and verify that the output current of repeater is in accordance with the input sensor current, within the specified accuracy. This requires that the input sensors / contacts or the proximity switches have already been tested without the repeater and they work correctly according to their performance.
4	Restore the loop to full operation.
5	Remove the bypass from the safety-related PLC or restore normal operation.

This test will detect approximately 99 % of possible Dangerous Undetected failures in the repeater.

D5034S and D5034D Switch/Proximity Detector Interface

• Safety function

The failure behaviour is described from the following definitions:

- fail-Safe State: is defined as the output going to fail low or high;
- fail Safe: failure mode that causes the module to go to the defined fail-safe state without a demand from the process;
- fail Dangerous: failure mode that does not respond to a demand from the process (i.e. being unable to go to the defined fail-safe state) or deviates the output current by more than 5 % (0.4 mA) of 8 mA full scale;
- fail High: failure mode that causes the output signal to go above 7 mA (short circuit of input);
- fail Low: failure mode that causes the output signal to go below 0.35 mA (input line breakage);
- fail "No Effect": failure mode of a component that is part of the safety function but that has no effect on the safety function or deviates the output current by not more than 5 % (0.4 mA) of 8 mA full scale. For the calculation of the SFF it is considered a safe undetected failure;
- fail "Not part": failure mode of a component which is not part of the safety function but part of the circuit diagram and is listed for completeness.
When calculating the SFF this failure mode is not taken into account. It is also not considered for the total failure rate (safety function) evaluation;
- fail "Not considered": failure mode not associated to the previous categories and divided in the 50 % safe failures and 50 % dangerous undetected failures;

Assuming that the application program in the safety logic solver is configured to detected under-range (Low) and over-range (High) failures and does not automatically trip on these failures, these failures have been classified as dangerous detected (DD) failures. The following PFDavg values have been calculated for different T[Proof] test intervals using the Markov model for 1oo1D architecture system, considering that the safety logic solver can convert the fail dangerous detected to the selected fail-safe state.

- The 2 channels of D5034D module could be used to increase the hardware fault tolerance, needed for a higher SIL of a certain Safety Function, as they are completely independent each other, not containing common components. In fact, the analysis results got for D5034S (single channel) are also valid for each channel of D5034D (double channel).

• Failure rates table:

Failure category	Failure rates (FIT)
$\lambda_{dd} = \text{Total Dangerous Detected failures} = \lambda_{dd \text{ int.}} + \lambda_{high} + \lambda_{low}$	136.80
↳ $\lambda_{dd \text{ int.}} = \text{Dangerous Detected failures (detected by diagnostics)}$	24.17
↳ $\lambda_{high} = \text{High failures (detected by the logic solver)}$	27.42
↳ $\lambda_{low} = \text{Low failures (detected by the logic solver)}$	85.21
$\lambda_{du} = \text{Total Dangerous Undetected failures} = \lambda_{du \text{ int.}} + 50\% * \lambda_{not \text{ considered}}$	19.25
↳ $\lambda_{du \text{ int.}} = \text{Dangerous Undetected failures}$	19.21
↳ $50\% * \lambda_{not \text{ considered}} = \text{"Not considered" or "undefined" failures}$	0.04
$\lambda_{sd} = \text{Total Safe Detected failures}$	0.00
$\lambda_{su} = \text{Total Safe Undetected failures} = \lambda_{no \text{ effect}} + 50\% * \lambda_{not \text{ considered}}$	158.76
↳ $\lambda_{no \text{ effect}} = \text{"No Effect" failures}$	158.72
↳ $50\% * \lambda_{not \text{ considered}} = \text{"Not considered" or "undefined" failures}$	0.04
$\lambda_{tot \text{ safe}} = \text{Total Failure Rate (Safety Function)} = \lambda_{dd} + \lambda_{du} + \lambda_{sd} + \lambda_{su}$	314.81
$\lambda_{not \text{ part}} = \text{"Not Part" failures}$	4.40
$\lambda_{tot \text{ device}} = \text{Total Failure Rate (Device)} = \lambda_{tot \text{ safe}} + \lambda_{not \text{ part}}$	319.21
MTBF (single channel) = $(1 / \lambda_{tot \text{ device}}) + \text{MTTR (8 hours)}$	357 years
$\text{MTTF}_S \text{ (Total Safe)} = 1 / (\lambda_{sd} + \lambda_{su})$	719 years
$\text{MTTF}_D \text{ (Dangerous)} = 1 / \lambda_{du}$	5930 years

• Failure rates table according to IEC 61508:

λ_{sd}	λ_{su}	λ_{dd}	λ_{du}	SFF	DC _s	DC _d
0.0 FIT	158.76 FIT	136.80 FIT	19.25 FIT	93.88%	0%	87.66%

• PFDavg vs T[Proof] table, with determination of SIL supposing module contributes 10% of entire safety function:

T[Proof] = 1 year	T[Proof] = 10 years
PFDavg = 8.43 E-05 Valid for SIL 3	PFDavg = 8.43 E-04 Valid for SIL 2

• PFDavg vs T[Proof] table, with determination of SIL supposing module contributes 20% of entire safety function:

T[Proof] = 2 years	T[Proof] = 20 years
PFDavg = 1.69 E-04 Valid for SIL 3	PFDavg = 1.69 E-03 Valid for SIL 2