



# INSTRUCTION MANUAL

SIL 3 Switch/Proximity Detector Repeater  
Relay Output, DIN Rail,  
Models D5030S, D5030D



## Characteristics

**General Description:** The single and dual channel Switch/Proximity Detector Repeater, D5030S and D5030D module is a unit suitable for applications requiring SIL 3 level (according to IEC 61508) in safety related systems for high risk industries.  
 The unit can be configured for switch or proximity detector (EN60947-5-6, NAMUR), NO or NC and for NE or ND SPST (D5030D) or SPDT (D5030S) relay output contact. Each channel enables a Safe Area load to be controlled by a switch, or a proximity detector, located in Hazardous Area.  
 Fault detection circuit (DIP switch configurable) is available for both proximity sensor and switch equipped with end of line resistors.  
 In case of fault, when enabled it de-energizes the corresponding output relay and turns the fault LED on; when disabled the corresponding output relay repeats the input line open or closed status as configured.

D5030D is programmable via dip switches as single input and two independent outputs. Out 2 can be programmed for output duplicating Out 1 or Fault detection Out. In case of duplication, relay actuation can be independently configured for each output.  
 In case of fault output, relay actuation can be programmed as normally energized or normally de-energized.

Mounting on standard DIN-Rail, with or without Power Bus, in Safe Area or in Zone 2.

## Technical Data

**Supply:** 24 Vdc nom (18 to 30 Vdc) reverse polarity protected, ripple within voltage limits  $\leq 5$  Vpp, 2 A time lag fuse internally protected.

**Current consumption @ 24 V:** 35 mA for 2 channels D5030D, 18 mA for 1 channel D5030S with short circuit input and relay energized, typical.

**Power dissipation:** 0.85 W for 2 channels D5030D, 0.45 W for 1 channel D5030S with 24 V supply voltage, short circuit input and relay energized, typical.

**Isolation (Test Voltage):** I.S. In/Out 2.5 KV; I.S. In/Supply 2.5 KV; I.S. In/ I.S In 500 V; Out/Supply 2.5 KV; Out/Out 2.5 KV.

**Input switching current levels:** ON  $\geq 2.1$  mA (1.9 to 6.2 mA range), OFF  $\leq 1.2$  mA (0.4 to 1.3 mA range), switch current  $\approx 1.65$  mA  $\pm 0.2$  mA hysteresis.

**Fault current levels:** open fault  $\leq 0.2$  mA, short fault  $\geq 6.8$  mA (when enabled both faults de-energize channel relay with single channel unit D5030S or de-energize channel relay with D5030D used as dual channel unit or actuate the fault relay out with D5030D used as fault signaling unit).

**Input equivalent source:** 8 V 1 K $\Omega$  typical (8 V no load, 8 mA short circuit).

**Output:** voltage free SPST (D5030D) or SPDT (D5030S) relay contact.

**Contact material:** Ag Alloy (Cd free).

**Contact rating:** 4 A 250 Vac 1000 VA, 4 A 250 Vdc 120 W (resistive load), limit current to 100 mA maximum for SIL 3 applications.

**DC Load breaking capacity:**

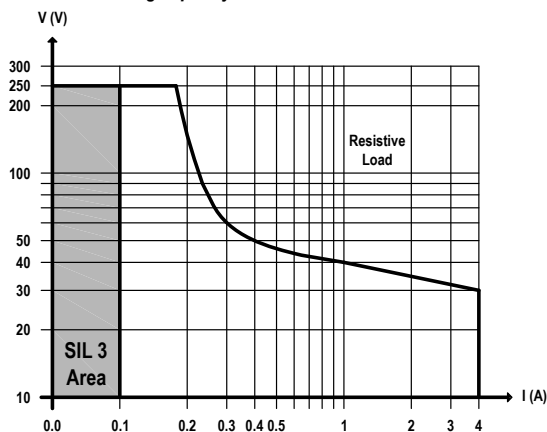

**Mechanical / Electrical life:**  $5 * 10^6 / 3 * 10^4$  operation, typical.

**Operate / Release time:** 8 / 4 ms typical.

**Bounce time NO / NC contact:** 3 / 8 ms typical.

**Frequency response:** 10 Hz maximum.

**Compatibility:**

**CE** CE mark compliant, conforms to 94/9/EC Atex Directive and to 2004/108/CE EMC Directive.

**Environmental conditions:**

**Operating:** temperature limits  $-40$  to  $+70$  °C, relative humidity 95 %, up to 55 °C.

**Storage:** temperature limits  $-45$  to  $+80$  °C.

**Safety Description:**



**ATEX:** II 3(1) G Ex nA nC [ia Ga] IIC T4 Gc, II (1) D [Ex ia Da] IIIC, I (M1) [Ex ia Ma] I

**IECEx:** Ex nA nC [ia Ga] IIC T4 Gc, [Ex ia Da] IIIC, [Ex ia Ma] I, associated apparatus and non-sparking electrical equipment.

Uo/Voc = 10.5 V, Io/Isc = 22 mA, Po/Po = 56 mW at terminals 7-8, 9-10.

Um = 250 Vrms,  $-40$  °C  $\leq$  Ta  $\leq 70$  °C.

**Approvals:** BVS 10 ATEX E 113 X conforms to EN60079-0, EN60079-11, EN60079-15, EN60079-26, EN61241-11, EN50303,

IECEx BVS 10.0072 X conforms to IEC60079-0, IEC60079-11, IEC60079-15, IEC60079-26, IEC1241-11.

Russia according to GOST 12.2.007.0-75, R 51330.0-99, R 51330.10-99, R 51330.14-99 2ExnAnC[ia]IIC T4 X.

Ukraine according to GOST 12.2.007.0, 22782.0, 22782.3, 22782.5 2Exs[ia]IIC T4 X.

TUV Certificate No. C-IS-204194-01, SIL 2 / SIL 3 conforms to IEC61508.

**Mounting:** T35 DIN-Rail according to EN50022, with or without Power Bus.

**Weight:** about 145 g D5030D, 120 g D5030S.

**Connection:** by polarized plug-in disconnect screw terminal blocks to accommodate terminations up to 2.5 mm<sup>2</sup>.

**Location:** Safe Area/Non Hazardous Locations or Zone 2, Group IIC T4 installation.

**Protection class:** IP 20.

**Dimensions:** Width 12.5 mm, Depth 123 mm, Height 120 mm.

## Ordering Information

Model:	D5030	
1 channel		S
2 channels		D

Power Bus and DIN-Rail accessories:  
 Connector JDFT049 Cover and fix MCHP196  
 Terminal block male MOR017 Terminal block female MOR022

## Front Panel and Features

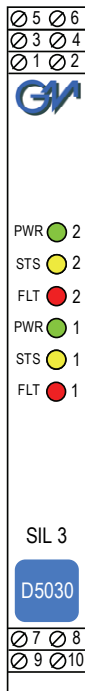

- SIL 3 according to IEC 61508 for T<sub>proof</sub> = 2 / 4 years (10 / 20 % of total SIF), considering 100 mA max contact current.
- SIL 2 according to IEC 61508 for T<sub>proof</sub> = 5 / 10 years (10 / 20 % of total SIF), considering 4 A max contact current.
- PFDavg (1 year) 4.87 E-05, SFF 96.49 %, considering 100 mA max contact current.
- PFDavg (1 year) 1.71 E-04, SFF 89.88 %, considering 4 A max contact current.
- 2 fully independent channels.
- Input from Zone 0 (Zone 20), installation in Zone 2.
- NO/NC switch/proximity Detector Input, NE/ND relay actuation mode.
- Field open and short circuit detection.
- Three port isolation, Input/Output/Supply.
- EMC Compatibility to EN61000-6-2, EN61000-6-4, EN61326-1, EN61326-3-1 for safety system.
- In-field programmability by DIP Switch.
- ATEX, IECEx, Russian and Ukrainian Certifications.
- High Density, two channels per unit.
- Simplified installation using standard DIN-Rail and plug-in terminal blocks, with or without Power Bus.
- 250 Vrms (Um) max. voltage allowed to the instruments associated with the barrier.

## Terminal block connections

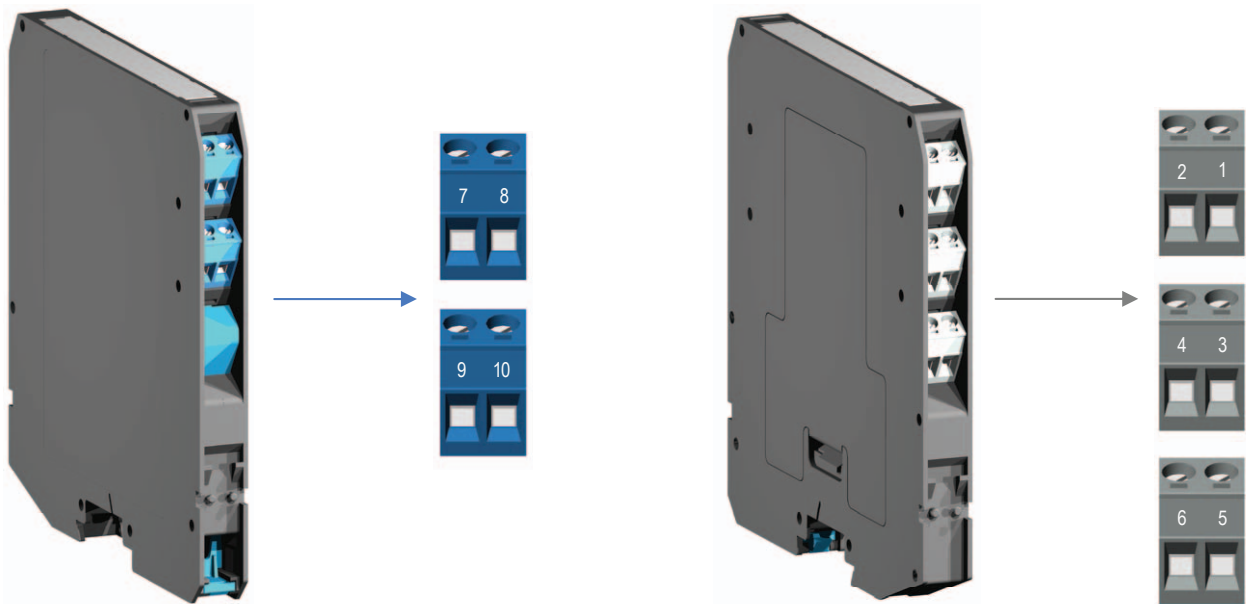

### HAZARDOUS AREA

- |           |  |
|-----------|--|
| <b>7</b>  | + Input Ch 1 for Proximity or Voltage free Contact |
| <b>8</b>  | - Input Ch 1 for Proximity or Voltage free Contact |
| <b>9</b>  | + Input Ch 2 for Proximity or Voltage free Contact |
| <b>10</b> | - Input Ch 2 for Proximity or Voltage free Contact |

### SAFE AREA

- |          |                       |
|----------|-----------------------|
| <b>1</b> | Output Ch 1           |
| <b>2</b> | Output Ch 1           |
| <b>3</b> | Output Ch 2           |
| <b>4</b> | Output Ch 2           |
| <b>5</b> | + Power Supply 24 Vdc |
| <b>6</b> | - Power Supply 24 Vdc |

## Parameters Table

In the system safety analysis, always check the Hazardous Area/Hazardous Locations devices to conform with the related system documentation, if the device is Intrinsically Safe check its suitability for the Hazardous Area/Hazardous Locations and group encountered and that its maximum allowable voltage, current, power ( $U_i/V_{max}$ ,  $I_i/I_{max}$ ,  $P_i/P_i$ ) are not exceeded by the safety parameters ( $U_o/V_{oc}$ ,  $I_o/I_{sc}$ ,  $P_o/P_o$ ) of the D5030 series Associated Apparatus connected to it. Also consider the maximum operating temperature of the field device, check that added connecting cable and field device capacitance and inductance do not exceed the limits ( $C_o/C_a$ ,  $L_o/L_a$ ,  $L_o/R_o$ ) given in the Associated Apparatus parameters for the effective group. See parameters indicated in the table below:

D5030 Terminals		D5030 Associated Apparatus Parameters		Must be	Hazardous Area/ Hazardous Locations Device Parameters
Ch1	7 - 8	$U_o / V_{oc} = 10.5 \text{ V}$		$\leq$	$U_i / V_{max}$
Ch2	9 - 10				
Ch1	7 - 8	$I_o / I_{sc} = 22 \text{ mA}$		$\leq$	$I_i / I_{max}$
Ch2	9 - 10				
Ch1	7 - 8	$P_o / P_o = 56 \text{ mW}$		$\leq$	$P_i / P_i$
Ch2	9 - 10				
D5030 Terminals		D5030 Associated Apparatus Parameters Cenelec (US)		Must be	Hazardous Area/ Hazardous Locations Device + Cable Parameters
Ch1	7 - 8	$C_o / C_a = 2.41 \mu\text{F}$	IIC (A, B)	$\geq$	$C_i / C_i \text{ device} + C \text{ cable}$
Ch2	9 - 10	$C_o / C_a = 16.80 \mu\text{F}$	IIB (C)		
		$C_o / C_a = 75.00 \mu\text{F}$	IIA (D)		
		$C_o / C_a = 66.00 \mu\text{F}$	I		
		$C_o / C_a = 16.80 \mu\text{F}$	iaD (E, F, G)		
Ch1	7 - 8	$L_o / L_a = 78.3 \text{ mH}$	IIC (A, B)	$\geq$	$L_i / L_i \text{ device} + L \text{ cable}$
Ch2	9 - 10	$L_o / L_a = 313.4 \text{ mH}$	IIB (C)		
		$L_o / L_a = 626.9 \text{ mH}$	IIA (D)		
		$L_o / L_a = 1028.6 \text{ mH}$	I		
		$L_o / L_a = 313.4 \text{ mH}$	iaD (E, F, G)		
Ch1	7 - 8	$L_o / R_o = 635.9 \mu\text{H}/\Omega$	IIC (A, B)	$\geq$	$L_i / R_i \text{ device and}$ $L \text{ cable} / R \text{ cable}$
Ch2	9 - 10	$L_o / R_o = 2543.9 \mu\text{H}/\Omega$	IIB (C)		
		$L_o / R_o = 5087.9 \mu\text{H}/\Omega$	IIA (D)		
		$L_o / R_o = 8347.4 \mu\text{H}/\Omega$	I		
		$L_o / R_o = 2543.9 \mu\text{H}/\Omega$	iaD (E, F, G)		

For installations in which both the  $C_i$  and  $L_i$  of the Intrinsically Safe apparatus exceed 1 % of the  $C_o$  and  $L_o$  parameters of the Associated Apparatus (excluding the cable), then 50 % of  $C_o$  and  $L_o$  parameters are applicable and shall not be exceeded (50 % of the  $C_o$  and  $L_o$  become the limits which must include the cable such that  $C_i \text{ device} + C \text{ cable} \leq 50 \% \text{ of } C_o$  and  $L_i \text{ device} + L \text{ cable} \leq 50 \% \text{ of } L_o$ ).

If the cable parameters are unknown, the following value may be used: Capacitance 180pF per meter (60pF per foot), Inductance 0.60μH per meter (0.20μH per foot).

## Function Diagram

HAZARDOUS AREA ZONE 0 (ZONE 20) GROUP IIC

SAFE AREA, ZONE 2 GROUP IIC T4

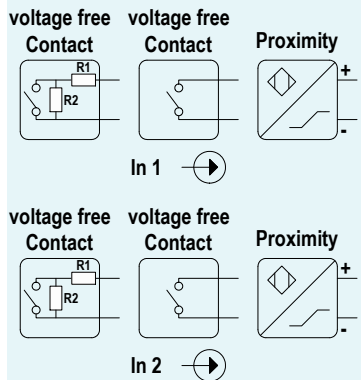

Resistors R1 - R2 used with voltage free contact required for line fault detection.

Terminals 9-10 must be shorted to set module as Duplicator or Fault Out

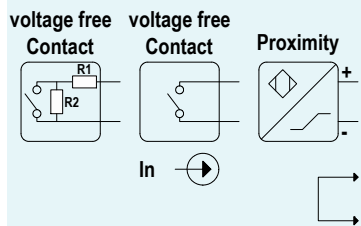

Resistors R1 - R2 used with voltage free contact required for line fault detection.

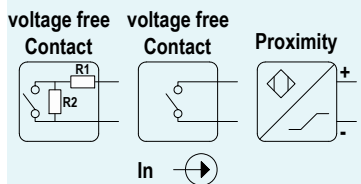

Resistors R1 - R2 used with voltage free contact required for line fault detection.

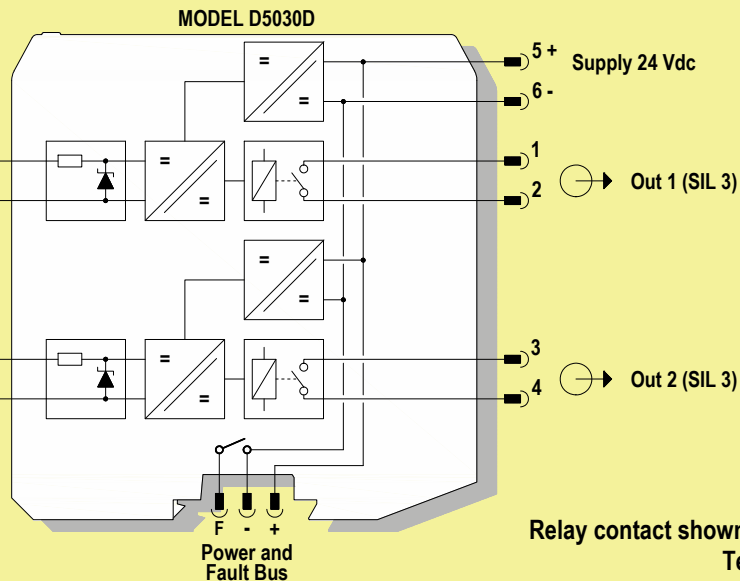

Relay contact shown in de-energized position. Terminals 1-2 and 3-4 open.

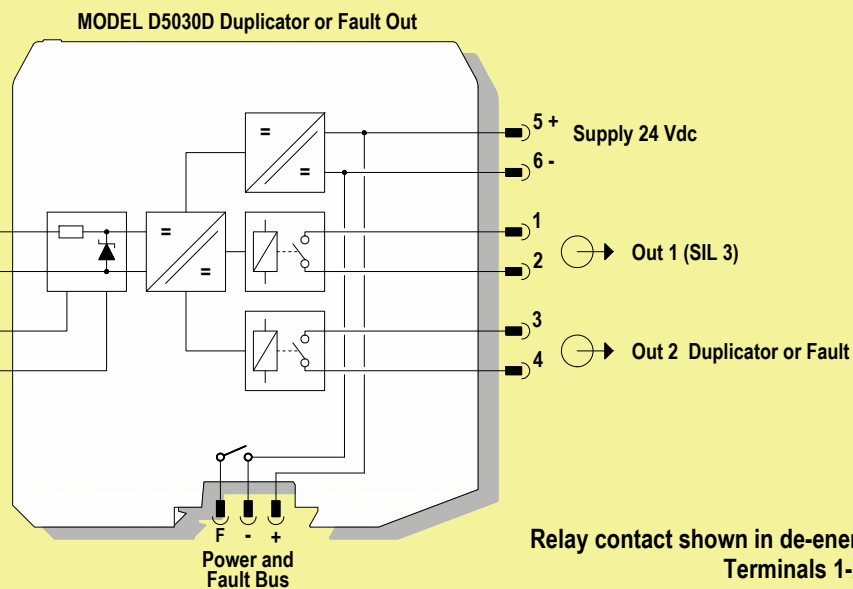

Relay contact shown in de-energized position. Terminals 1-2 and 3-4 open.

Internal Dip switches programmable

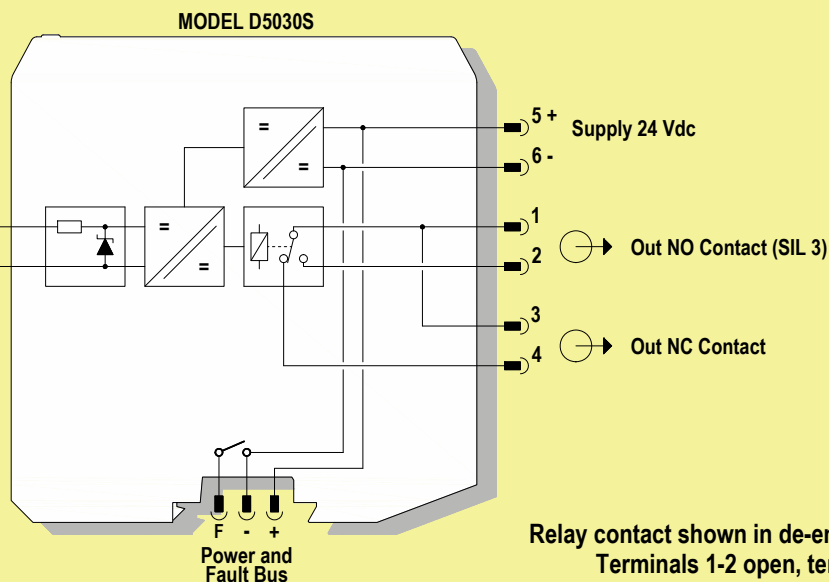

Relay contact shown in de-energized position. Terminals 1-2 open, terminals 3-4 close.

## Warning

D5030 series are isolated Intrinsically Safe Associated Apparatus installed into standard EN50022 T35 DIN-Rail located in Safe Area or Zone 2, Group IIC, Temperature T4, Hazardous Area (according to EN/IEC60079-15) within the specified operating temperature limits Tamb -40 to +70 °C, and connected to equipment with a maximum limit for AC power supply Um of 250 Vrms.

Not to be connected to control equipment that uses or generates more than 250 Vrms or Vdc with respect to earth ground.

D5030 series must be installed, operated and maintained only by qualified personnel, in accordance to the relevant national/international installation standards (e.g. IEC/EN60079-14 Electrical apparatus for explosive gas atmospheres - Part 14: Electrical installations in hazardous areas (other than mines)), following the established installation rules, particular care shall be given to segregation and clear identification of I.S. conductors from non I.S. ones.

De-energize power source (turn off power supply voltage) before plug or unplug the terminal blocks when installed in Hazardous Area or unless area is known to be nonhazardous.

**Warning: substitution of components may impair Intrinsic Safety and suitability for Zone 2.**

**Explosion Hazard: to prevent ignition of flammable or combustible atmospheres, disconnect power before servicing or unless area is known to be nonhazardous.**

Failure to properly installation or use of the equipment may risk to damage the unit or severe personal injury.

The unit cannot be repaired by the end user and must be returned to the manufacturer or his authorized representative.

Any unauthorized modification must be avoided.

## Operation

D5030 module is a unit suitable for applications requiring SIL 3 level (according to IEC 61508) in safety related systems for high risk industries.

The unit can be configured for switch or proximity detector (EN60947-5-6, NAMUR), NO or NC and for NE or ND SPST (D5030D) or SPDT (D5030S) relay output contact.

Each channel enables a Safe Area load to be controlled by a switch, or a proximity detector, located in Hazardous Area.

Fault detection circuit (DIP switch configurable) is available for both proximity sensor and switch equipped with end of line resistors. In case of fault, when enabled it de-energizes the corresponding output relay and turns the fault LED on; when disabled the corresponding output relay repeats the input line open or closed status as configured.

D5030D is programmable via dip switches as single input and two independent outputs. Out 2 can be programmed for output duplicating Out 1 or Fault detection Out.

In case of duplication, relay actuation can be independently configured for each output.

In case of fault output, relay actuation can be programmed as normally energized or normally de-energized.

Presence of supply power and status of output (energized or de-energized), as well as integrity or fault condition of sensor and connecting line are displayed by signaling LEDs (green for power, yellow for status and red for fault condition).

**Note:** use of voltage free electrical contacts with fault detection enabled (control equipment) requires, near the switch at the end of the line a R1=1 K $\Omega$  typical (470  $\Omega$  to 2 K $\Omega$  range) resistor in series and a R2=10 k $\Omega$  typical (5 K $\Omega$  to 15 K $\Omega$  range) resistor in parallel to the contacts in order to allow the fault detection circuit to distinguish between a condition of contact close/open and a line open/short circuit fault.

## Installation

D5030 series are Switch/Proximity Detector Interface housed in a plastic enclosure suitable for installation on T35 DIN-Rail according to EN50022, with or without Power Bus.

D5030 unit can be mounted with any orientation over the entire ambient temperature range.

Electrical connection of conductors up to 2.5 mm<sup>2</sup> are accommodated by polarized plug-in removable screw terminal blocks which can be plugged in/out into a powered unit without suffering or causing any damage (**for Zone 2 installations check the area to be nonhazardous before servicing**).

The wiring cables have to be proportionate in base to the current and the length of the cable.

On the section "Function Diagram" and enclosure side a block diagram identifies all connections.

Identify the number of channels of the specific card (e.g. D5030S is a single channel model and D5030D is a dual channel model), the function and location of each connection terminal using the wiring diagram on the corresponding section, as an example:

Connect 24 Vdc power supply positive at terminal "5" and negative at terminal "6".

For Model D5030S connect output of channel 1 at terminals "1" and "2".

For Model D5030D in addition to channel 1 connections above, connect output of channel 2 at terminals "3" and "4".

For Model D5030S, in case of Proximity or Voltage free Contact, connect the wires at terminal "7" for positive and "8" for negative.

For Model D5030D in addition to channel 1 connections above, connect terminal "9" for positive and "10" for negative on channel 2.

Intrinsically Safe conductors must be identified and segregated from non I.S. and wired in accordance to the relevant national/international installation standards (e.g. EN/IEC60079-14 Electrical apparatus for explosive gas atmospheres - Part 14: Electrical installations in hazardous areas (other than mines)), make sure that conductors are well isolated from each other and do not produce any unintentional connection.

Connect SPDT (D5030S) or SPST (D5030D) relay contacts checking the load rating to be within the contact maximum rating (4 A 250 Vac 1000 VA, 4 A 250 Vdc 120 W resistive load, limit current to 100 mA maximum for SIL 3 applications).

**If necessary, to prevent relay contacts from damaging, an external protection (fuse or similar) should be connected. A suitable protection must be chosen according to the relay breaking capacity diagram on data sheet.**

The enclosure provides, according to EN60529, an IP20 minimum degree of mechanical protection (or similar to NEMA Standard 250 type 1) for indoor installation, outdoor installation requires an additional enclosure with higher degree of protection (i.e. IP54 to IP65 or NEMA type 12-13) consistent with the effective operating environment of the specific installation.

Units must be protected against dirt, dust, extreme mechanical (e.g. vibration, impact and shock) and thermal stress, and casual contacts.

If enclosure needs to be cleaned use only a cloth lightly moistened by a mixture of detergent in water.

**Electrostatic Hazard: to avoid electrostatic hazard, the enclosure of D5030 must be cleaned only with a damp or antistatic cloth.**

Any penetration of cleaning liquid must be avoided to prevent damage to the unit. Any unauthorized card modification must be avoided.

According to EN61010, D5030 series must be connected to SELV or SELV-E supplies.

Relay output contact must be connected to load non exceeding category II overvoltage limits.

**Warning: de-energize main power source (turn off power supply voltage) and disconnect plug-in terminal blocks before opening the enclosure to avoid electrical shock when connected to live hazardous potential.**

## Start-up

Before powering the unit check that all wires are properly connected, particularly supply conductors and their polarity, input and output wires, also check that Intrinsically Safe conductors and cable trays are segregated (no direct contacts with other non I.S. conductors) and identified either by color coding, preferably blue, or by marking. Check conductors for exposed wires that could touch each other causing dangerous unwanted shorts. Turn on power, the "power on" green led must be lit, status and fault led on each channel must be in accordance with condition of the corresponding input line. If possible close and open input lines one at time checking the corresponding status and fault leds condition as well as output to be correct.

### D5030D used as double channel

A configuration DIP switch is located on component side of pcb. This switch allows the configuration of input/output relationship, fault detection functions and operating mode.

**WARNING:** dip-switch 6-7-8 must be set to "OFF" position.

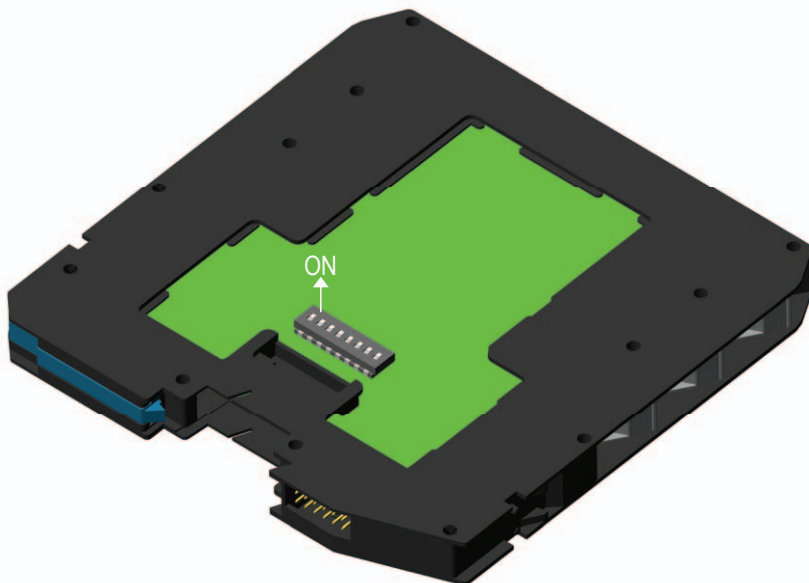

Dip switch configuration

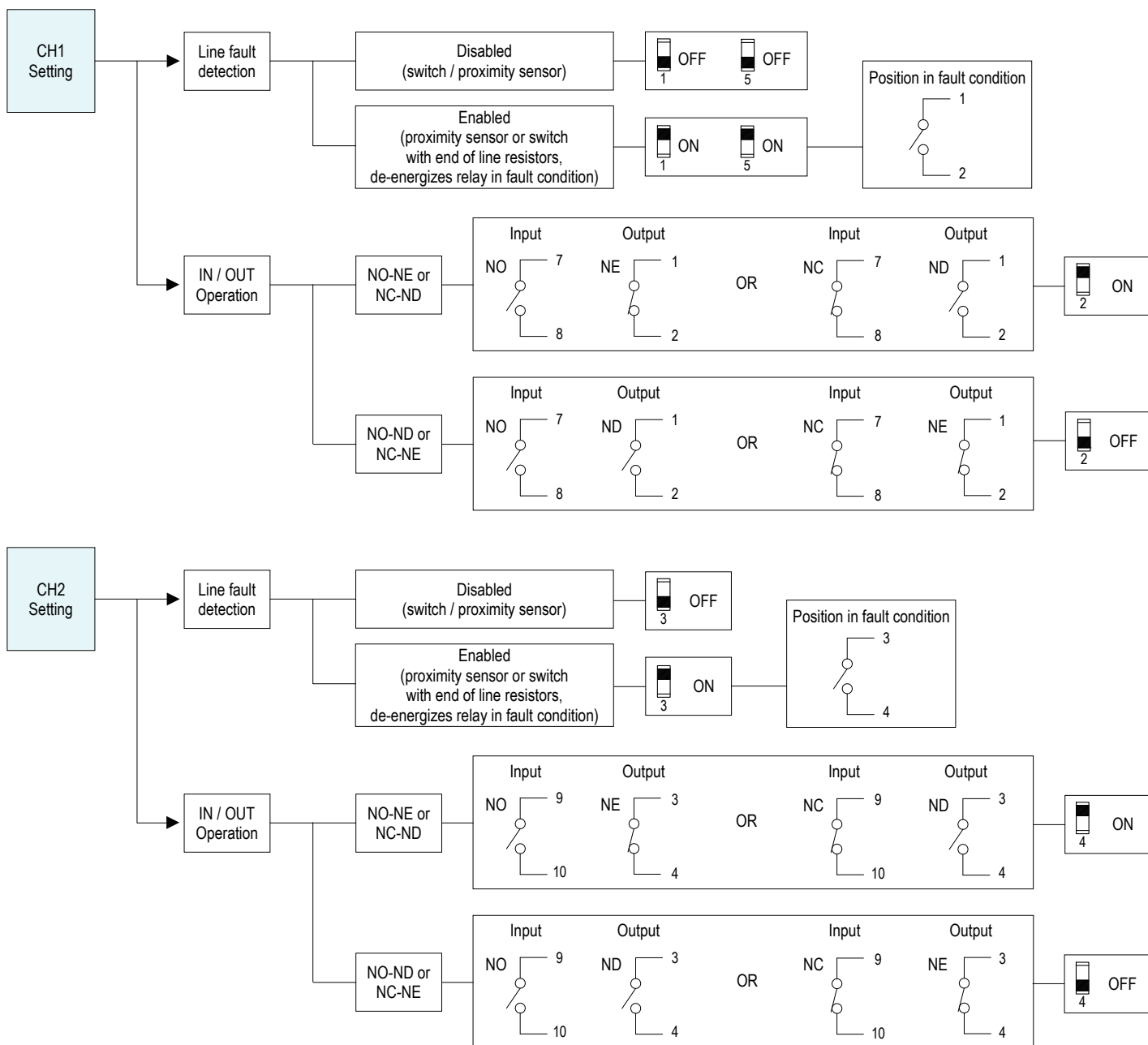
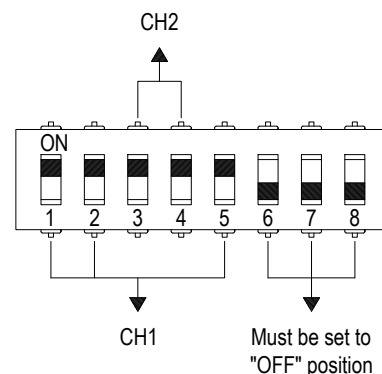

### D5030D used as duplicator or fault output

A configuration DIP switch is located on component side of pcb. This switch allows the configuration of input/output relationship, fault detection functions and operating mode.

**WARNING: Terminals 9-10 must be shorted to set module as Duplicator or Fault Out.**

Dip-switch 3 must be set to "OFF" position.

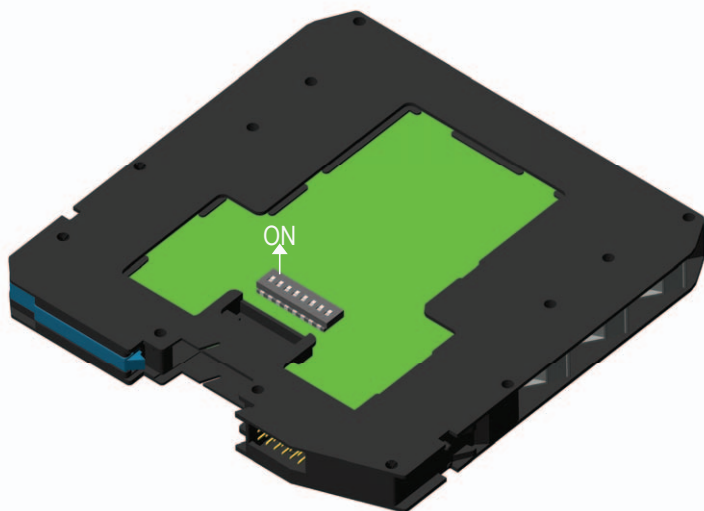

Dip switch configuration

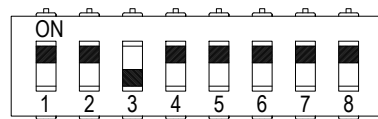

Must be set to "OFF" position

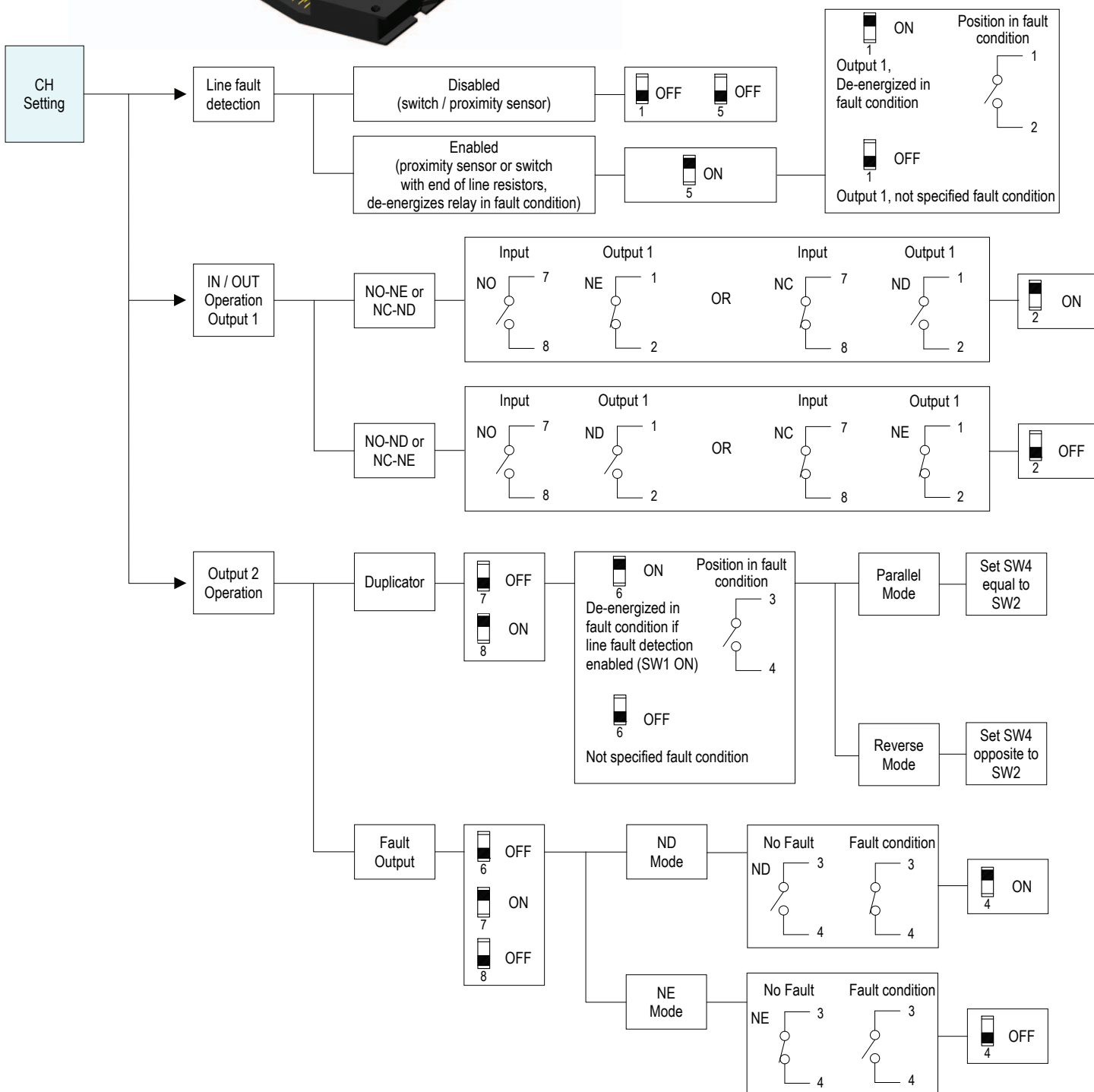



**D5030S**

A configuration DIP switch is located on component side of pcb. This switch allows the configuration of input/output relationship, fault detection functions and operating mode.

**WARNING:** Dip-switch 7-8 must be set to "OFF" position.

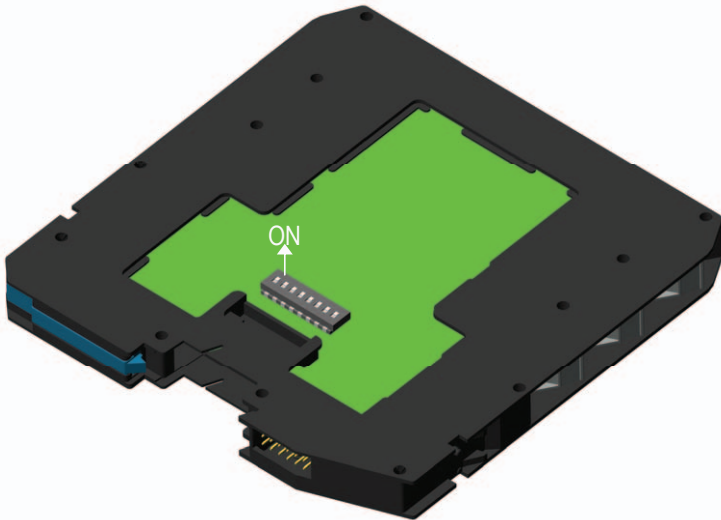

Dip switch configuration

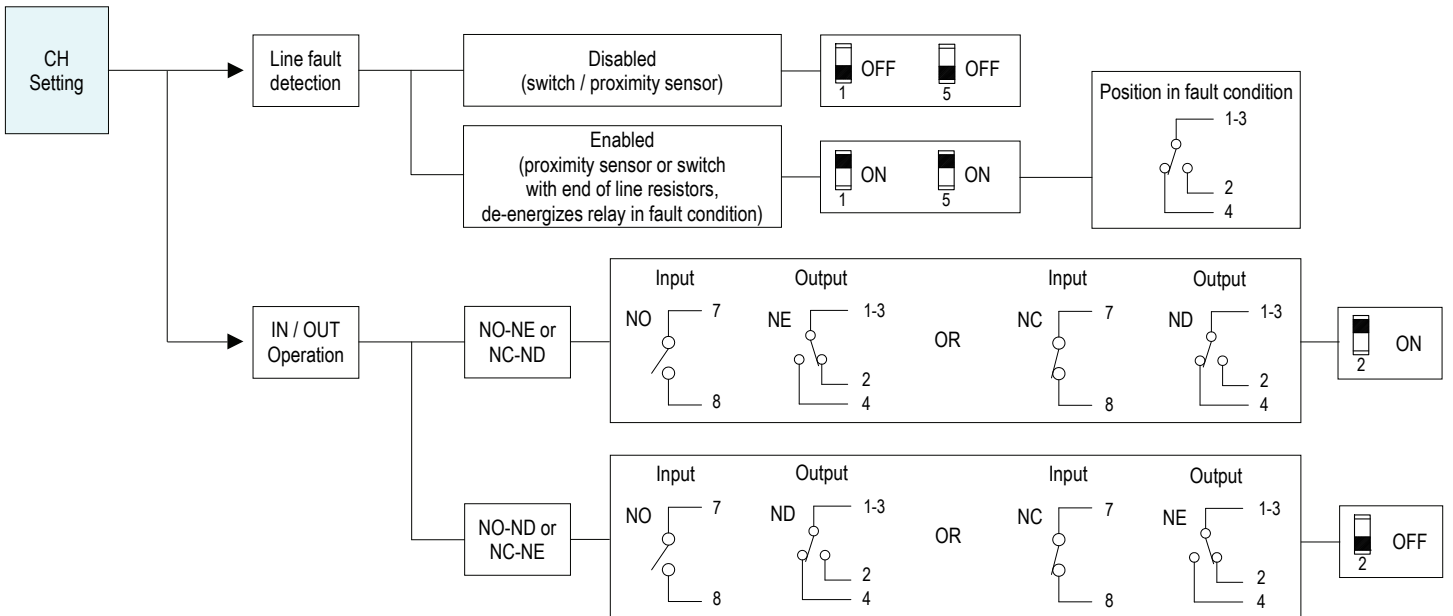
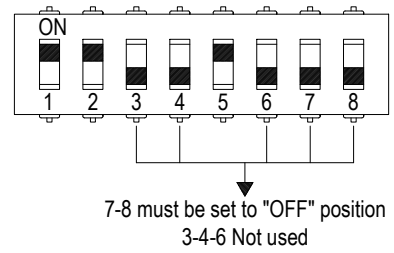

### D5030D (used as double channel) Configuration Summary Table

**WARNING:** dip-switch 6-7-8 must be set to “OFF” position.

Channel	1		2	Channel	1	2
Line fault detection	SW1	SW5	SW3	IN/OUT Operation	SW2	SW4
Disabled (switch/proximity sensor)	OFF	OFF	OFF	NO-NE or NC-ND	ON	ON
Enabled (proximity sensor or switch with end of line resistors, detects field open circuit and short circuit, de-energizes relay in fault condition)	ON	ON	ON	NO-ND or NC-NE	OFF	OFF

### D5030D (used as duplicator or fault output) Configuration Summary Table

**WARNING:** Terminals 9-10 must be shorted to set module as Duplicator or Fault Out. Dip-switch 3 must be set to “OFF” position.

Line fault detection	SW1	SW5	IN/OUT Operation Output 1	SW2
Disabled (switch/proximity sensor)	OFF		NO-NE or NC-ND	ON
Enabled (proximity sensor or switch with end of line resistors, detects field open circuit and short circuit, de-energizes relay in fault condition)	Output 1, De-energized in Fault condition	ON		
	Output 1, Not specified Fault condition	OFF	NO-ND or NC-NE	OFF

Output 2 Operation	SW6	SW7	SW8	Mode	SW4
Duplicator	De-energized in fault condition if line fault detection enabled (SW1 ON)	ON	OFF	ON	Parallel Set equal to SW2
	Not specified Fault condition	OFF			Reverse Set opposite to SW2
Fault Output	OFF	ON	OFF	ND	ON
				NE	OFF

### D5030S Configuration Summary Table

**WARNING:** Dip-switch 7-8 must be set to “OFF” position.

Line fault detection	SW1	SW5	IN/OUT Operation	SW2
Disabled (switch/proximity sensor)	OFF	OFF	NO-NE or NC-ND	ON
Enabled (proximity sensor or switch with end of line resistors, detects field open circuit and short circuit, de-energizes relay in fault condition)	ON	ON	NO-ND or NC-NE	OFF

### Testing procedure at T-proof

The proof test shall be performed to reveal dangerous faults which are undetected by diagnostic. This means that it is necessary to specify how dangerous undetected fault, which have been noted during the FMEDA, can be detected during proof test.

**Note for switch input:** to detect a broken wire, or a short circuit condition, in the input connections it is necessary to mount, close to the switches, the end of line resistors: R1=1 K $\Omega$  typical (470  $\Omega$  to 2 K $\Omega$  range) resistor in series and R2=10 k $\Omega$  typical (5 K $\Omega$  to 15 K $\Omega$  range) resistor in parallel to the contacts.

The Proof test consists of the following steps:

Steps	Action
1	Bypass the safety-related PLC or take other appropriate action to avoid a false trip.
2	Vary the state conditions of the input sensors/contacts coming from field and verify that relay outputs change from de-energized to energized and vice versa, then check that the de-energized state condition corresponds to the required safety-related function.
3	If input line fault detection is enable for each channel by means of Dip-switches specific set up, disconnect the input wiring coming from the field sensor/contact and check that the correspondent relay output is de-energized. Then, put in short condition the input connections and verify that the same output remains de-energized. In both case the proper alarm LEDs, on the front panel, will be came red.
4	Restore the loop to full operation.
5	Remove the bypass from the safety-related PLC or restore normal operation.

This test will detect approximately 99 % of possible Dangerous Undetected failures in the repeater.

**D5030S and D5030D Switch/Proximity Detector Repeater, Relay Output with 100 mA or 4 A maximum contact current**

Safety function

For each channel, the 2<sup>nd</sup> In / Out operation mode (NO-ND or NC-NE) has been chosen (in the D5030S module, NO contact is only used as safety purpose, while NC contact is used for service purpose) and the input line fault detection has been enabled to de-energize the output relay in case of fault.

The failure behaviour of each channel is described from the following definitions:

- fail-Safe State: is defined as the relay output is de-energized (NO contact is open);
- fail Safe: failure mode that causes the module to go to the defined fail-safe state without a demand from the process;
- fail Dangerous: failure mode that does not respond to a demand from the process (i.e. being unable to go to the defined fail-safe state), so that the relay output remains energized (NO contact is blocked in closed position);
- fail "No Effect": failure mode of a component that is part of the safety function but that has no effect on the safety function. For the calculation of the SFF it is considered a safe undetected failure;
- fail "Not part": failure mode of a component which is not part of the safety function but part of the circuit diagram and is listed for completeness.  
When calculating the SFF this failure mode is not taken into account. It is also not considered for the total failure rate (safety function) evaluation.

- The 2 channels of D5030D module could be used to increase the hardware fault tolerance, needed for a higher SIL of a certain Safety Function, as they are completely independent each other, not containing common components. In fact, the analysis results got for D5030S (single channel) are also valid for each channel of D5030D (double channel).

- Failure rates table:

Failure category	Failure rates (FIT) 100 mA maximum contact current	Failure rates (FIT) 4 A maximum contact current
$\lambda_{dd}$ = Total Dangerous Detected failures	0.00	0.00
$\lambda_{du}$ = Total Dangerous Undetected failures	11.13	39.13
$\lambda_{sd}$ = Total Safe Detected failures	0.00	0.00
$\lambda_{su}$ = Total Safe Undetected failures = $\lambda_{su\ int} + \lambda_{no\ effect}$	305.67	347.67
↳ $\lambda_{su\ int}$ = Safe Undetected failures	141.95	183.95
↳ $\lambda_{no\ effect}$ = "No Effect" failures	163.72	163.72
<b><math>\lambda_{tot\ safe}</math> = Total Failure Rate (Safety Function) = <math>\lambda_{dd} + \lambda_{du} + \lambda_{sd} + \lambda_{su}</math></b>	<b>316.80</b>	<b>386.80</b>
$\lambda_{not\ part}$ = "Not Part" failures	6.20	6.20
<b><math>\lambda_{tot\ device}</math> = Total Failure Rate (Device) = <math>\lambda_{tot\ safe} + \lambda_{not\ part}</math></b>	<b>323.00</b>	<b>393.00</b>
<b>MTBF (single channel) = <math>(1 / \lambda_{tot\ device}) + MTTR</math> (8 hours)</b>	<b>353 years</b>	<b>290 years</b>
$MTTF_S$ (Total Safe) = $1 / (\lambda_{sd} + \lambda_{su})$	373 years	328 years
$MTTF_D$ (Dangerous) = $1 / \lambda_{du}$	10256 years	2917 years

- Failure rates table according to IEC 61508:

	$\lambda_{sd}$	$\lambda_{su}$	$\lambda_{dd}$	$\lambda_{du}$	SFF
<b>100 mA maximum contact current</b>	0.0 FIT	305.67 FIT	0.00 FIT	11.13 FIT	96.49%
<b>4 A maximum contact current</b>	0.0 FIT	347.67 FIT	0.00 FIT	39.13 FIT	89.88%

- PFDavg vs T[Proof] table, with determination of SIL supposing module contributes 10% of entire safety function:

	T[Proof] = 1 year	T[Proof] = 2 years	T[Proof] = 5 years	T[Proof] = 20 years
<b>100 mA maximum contact current</b>	PFDavg = 4.87 E-05 Valid for <b>SIL 3</b>	PFDavg = 9.75 E-05 Valid for <b>SIL 3</b>	PFDavg = 2.44 E-04 Valid for <b>SIL 2</b>	PFDavg = 9.75 E-04 Valid for <b>SIL 2</b>
<b>4 A maximum contact current</b>	PFDavg = 1.71 E-04 Valid for <b>SIL 2</b>	PFDavg = 3.43 E-04 Valid for <b>SIL 2</b>	PFDavg = 8.57 E-04 Valid for <b>SIL 2</b>	PFDavg = 3.43 E-03 Valid for <b>SIL 1</b>

- PFDavg vs T[Proof] table, with determination of SIL supposing module contributes 20% of entire safety function:

	T[Proof] = 4 years	T[Proof] = 10 years	T[Proof] = 20 years
<b>100 mA maximum contact current</b>	PFDavg = 1.95 E-04 Valid for <b>SIL 3</b>	PFDavg = 4.87 E-04 Valid for <b>SIL 2</b>	PFDavg = 9.75 E-04 Valid for <b>SIL 2</b>
<b>4 A maximum contact current</b>	PFDavg = 6.86 E-04 Valid for <b>SIL 2</b>	PFDavg = 1.71 E-03 Valid for <b>SIL 2</b>	PFDavg = 3.43 E-03 Valid for <b>SIL 1</b>