



INSTRUCTION MANUAL

SIL 3 Relay Output Module
DIN-Rail Models D1092S, D1092D

SIL Applications

For Safety Related System and SIL2, SIL3 Applications according IEC61508 & IEC61511 Standards refer to "Functional Safety Manual" document number ISM0071

Characteristics

General Description: The single and dual channel DIN Rail Relay Output, D1092S and D1092D are relay modules suitable for the switching of safety related circuits, up to SIL 3 level according to IEC61508, for high risk industries. It provides isolation between input and output contacts.

D1092S provides 1 SPST contact for normally energized loads and 1 SPST contact for normally de-energized loads.

D1092D provides 2 SPST contact for normally energized loads and 2 SPST contact for normally de-energized loads.

When the relay is energized, the contacts are closed. When the relay is de-energized, the contacts are open.

Function: 1 or 2 totally independent and isolated relay for safety related circuits, provides isolation between input and output.

D1092S: SIL 3 Safety Function for NE load (de-energized in safe state) is available at Terminal Blocks 1-2; in this case, the safety function is met when the relay is de-energized (open contact).

SIL 3 Safety Function for ND load (energized in safe state) is available at Terminal Blocks 3-4; in this case, the safety function is met when the relay is energized (closed contact).

D1092D: SIL 3 Safety Function NE load (de-energized in safe state) is available at Terminal Blocks 1-2 and Terminal Blocks 5-6; in this case, the safety function is met when the relays are de-energized (open contact). SIL 3 Safety Function for ND load (energized in safe state) is available at Terminal Blocks 3-4 and Terminal Blocks 7-8; in this case the safety function is met when the relays are energized (closed contact).

Signalling LEDs: Relay status (yellow).

EMC: Fully compliant with CE marking applicable requirements.

Technical Data

Input: 24 Vdc nom (20.4 to 27.6 Vdc) reverse polarity protected, ripple within voltage limits ≤ 5 Vpp.

Current consumption @ 24 V: 50 mA for each channel with relay energized, typical (100 mA for 2 channels D1092D when used as duplicator 1 input / 2 outputs).

Power dissipation: 1.2 W for each channel with 24 V input voltage and relay energized, typical (2.4 W for 2 channels D1092D when used as duplicator).

Max. power consumption: at 27.6 V input voltage and relay energized, 1.5 W for each channel (3.0 W for 2 channels D1092D when used as duplicator).

Isolation (Test Voltage): Input/Output 2.5 KV; Input/Input 500 V; Output/Output 2.5 KV; Output A/Output B 1.5 KV.

Output: voltage free DPST relay contact, normally open.

Contact material: Ag Alloy (Cd free).

Contact rating: 3 A 250 Vac 750 VA, 3 A 125 Vdc 120 W (resistive load).

DC Load breaking capacity:

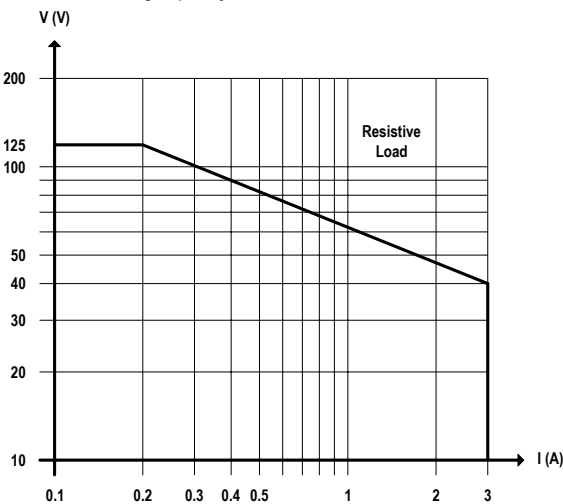

Mechanical / Electrical life: $50 \times 10^6 / 1 \times 10^5$ operation, typical.

Operate / Release time: 5 / 3 ms typical.

Bounce time NO / NC contact: 3 ms.

Frequency response: 10 Hz maximum.

Compatibility:



CE mark compliant, conforms to 94/9/EC Atex Directive and to 2004/108/CE EMC Directive.

Environmental conditions: Operating: temperature limits -20 to $+60$ °C, relative humidity max 90 % non condensing, up to 35 °C.

Storage: temperature limits -45 to $+80$ °C.

Safety Description:



II 3G Ex nAC IIC T4 non-incendive electrical apparatus. -20 °C \leq Ta \leq 60 °C.

Approvals: IMQ 09 ATEX 013 X conforms to EN60079-0, EN60079-15,

FM & FM-C No. 3024643, 3029921C, conforms to Class 3600, 3611, 3810 and C22.2 No.142, C22.2 No.213, E60079-0, E60079-15.

TUV Certificate No. C-IS-183645-01, SIL 3 according to IEC 61508. Please refer to Functional Safety Manual for SIL applications.

Proof Test Interval: 10 years for SIL3 application with NE load or 7 years with ND load or 20 years for SIL3 application with NE load or 15 years with ND load (20 % of SIF).

Mounting: T35 DIN Rail according to EN50022.

Weight: about 160 g D1092D, 125 g D1092S.

Connection: by polarized plug-in disconnect screw terminal blocks to accommodate terminations up to 2.5 mm².

Location: Safe Area/Non Hazardous Locations or Zone 2, Group IIC T4, Class I, Division 2, Groups A, B, C, D Temperature Code T4 and Class I, Zone 2, Group IIC, IIB, IIA T4 installation.

Protection class: IP 20.

Dimensions: Width 22.5 mm, Depth 99 mm, Height 114.5 mm.

Ordering information

Model:	D1092	
1 channel		S
2 channels		D

Front Panel and Features

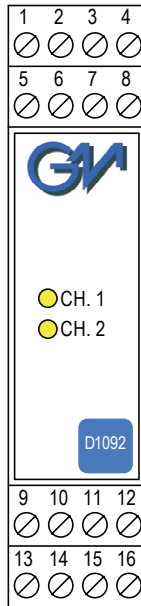

- SIL 3 according to IEC 61508 for Tproof = 10 / 20 years (10 / 20 % of total SIF) with NE Load.
- SIL 3 according to IEC 61508 for Tproof = 7 / 15 years (10 / 20 % of total SIF) with ND Load.
- PFDavg (1 year) 7.01 E-06, SFF 99.13 % with NE Load.
- PFDavg (1 year) 1.14 E-05, SFF 97.95 % with ND Load.
- Installation in Zone 2, Division 2.
- 2 fully independent channels.
- 1 SPST contact for NE load and 1 SPST contact for ND load for each channel.
- Input/Output isolation.
- EMC Compatibility to EN61000-6-2, EN61000-6-4.
- ATEX, FM & FM-C Certifications.
- TUV Certification for SIL.
- High Reliability, SMD components.
- High Density, two channels per unit.
- Simplified installation using standard DIN Rail and plug-in terminal blocks.

Terminal block connections

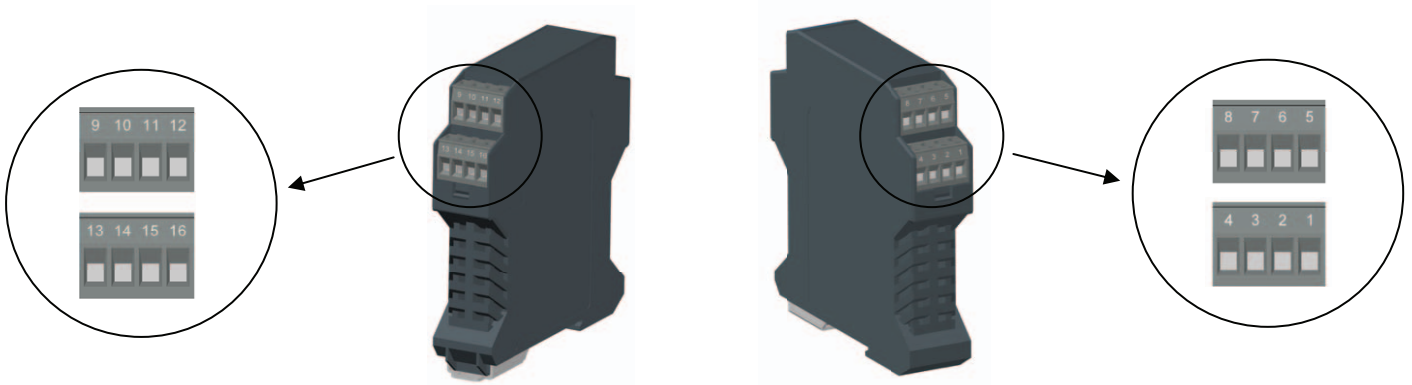

SAFE AREA

9	+ Input Ch 1 connects to terminal 13
10	+ Input Ch 2 connects to terminal 15
11	- Input Ch 1 connects to terminal 14
12	- Input Ch 2 connects to terminal 16
13	+ Input Ch 1
14	- Input Ch 1
15	+ Input Ch 2
16	- Input Ch 2

SAFE AREA

1	Output Ch 1-A for NE Load
2	Output Ch 1-A for NE Load
3	Output Ch 1-B for ND Load
4	Output Ch 1-B for ND Load
5	Output Ch 2-A for NE Load
6	Output Ch 2-A for NE Load
7	Output Ch 2-B for ND Load
8	Output Ch 2-B for ND Load

Function Diagram

SAFE AREA, ZONE 2 GROUP IIC T4,
NON HAZARDOUS LOCATIONS, CLASS I, DIVISION 2, GROUPS A, B, C, D T-Code T4, CLASS I, ZONE 2, GROUP IIC T4

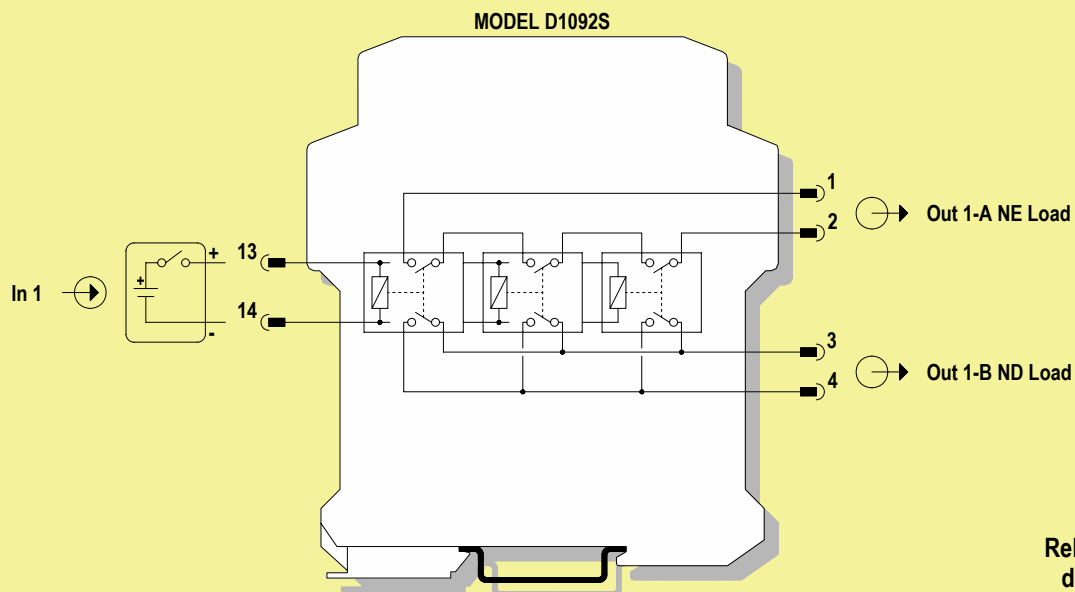
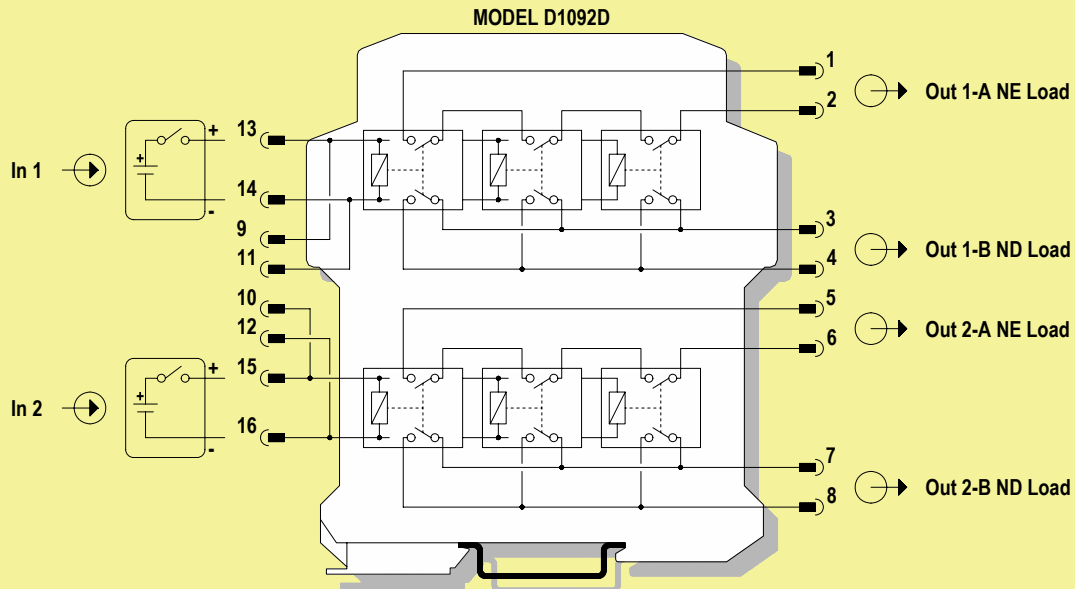

Relay contact shown in de-energized position

Application for D1092S - Normally Energized Condition (NE)

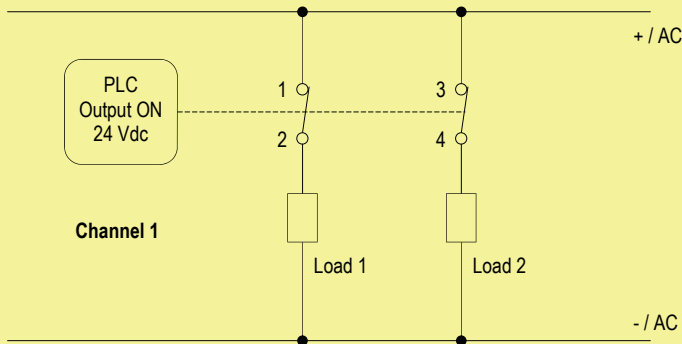

Channel 1

Contacts 1-2: SIL 3 Function is met when contacts are in open state.
Contacts 3-4: Opening of contacts can be used for monitoring Contacts 1-2. No SIL Function.

Application for D1092S - Normally De-Energized Condition (ND)

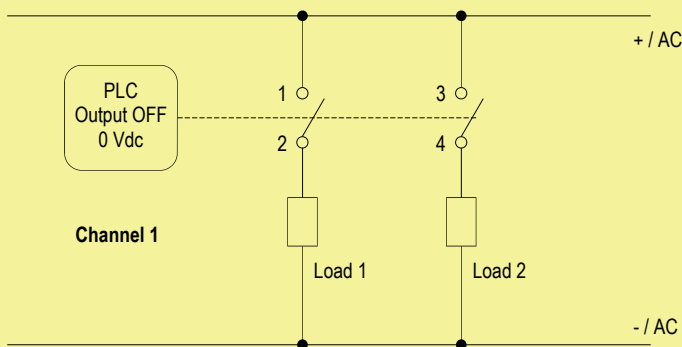

Channel 1

Contacts 1-2: Closing of contacts can be used for monitoring Contacts 3-4. No SIL Function.
Contacts 3-4: SIL 3 Function is met when contacts are in closed state.

Application for D1092D - Normally Energized Condition (NE) and two independent driving signals from PLC

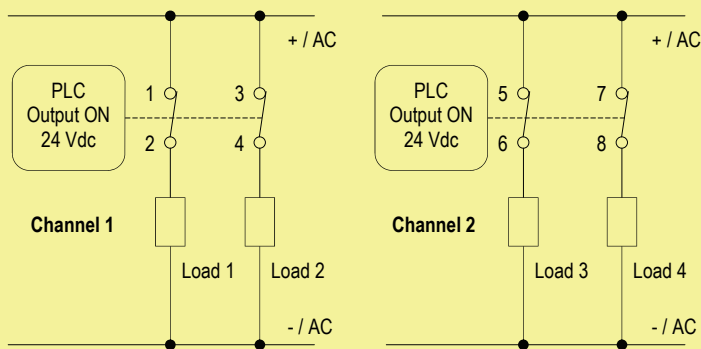

Channel 1

Contacts 1-2: SIL 3 Function is met when contacts are in open state.
Contacts 3-4: Opening of contacts can be used for monitoring Contacts 1-2. No SIL Function.

Channel 2

Contacts 5-6: SIL 3 Function is met when contacts are in open state.
Contacts 7-8: Opening of contacts can be used for monitoring Contacts 5-6. No SIL Function.

Application for D1092D - Normally De-Energized Condition (ND) and two independent driving signals from PLC

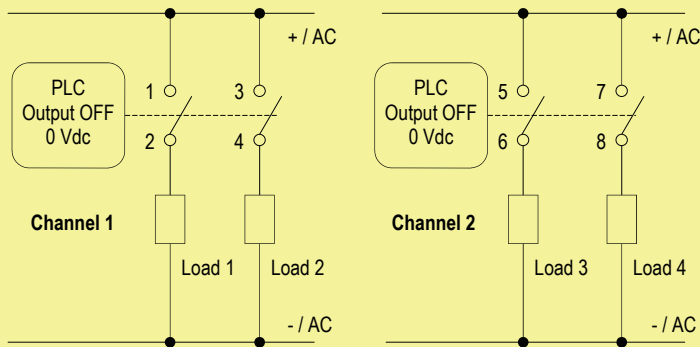

Channel 1

Contacts 1-2: Closing of contacts can be used for monitoring Contacts 3-4. No SIL Function.

Contacts 3-4: SIL 3 Function is met when contacts are in closed state.

Channel 2

Contacts 5-6: Closing of contacts can be used for monitoring Contacts 7-8. No SIL Function.

Contacts 7-8: SIL 3 Function is met when contacts are in closed state.

Application for D1092D - Normally Energized Condition (NE) and one common driving signal from PLC for the two relays

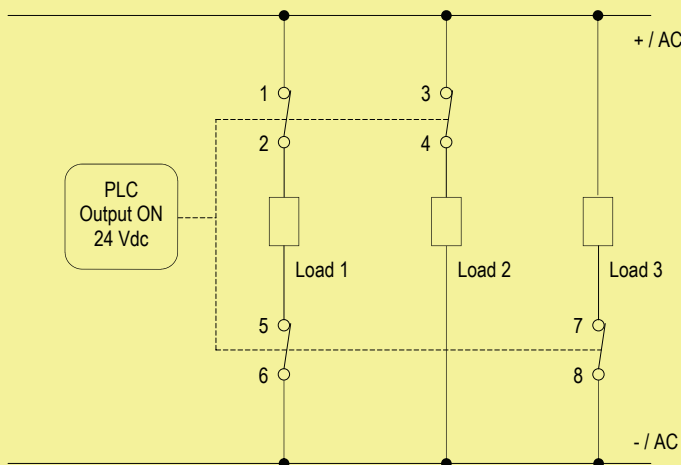

Contacts 1-2: SIL 3 Function is met when contacts are in open state.

Contacts 3-4: Opening of contacts can be used for monitoring Contacts 1-2. No SIL Function.

Contacts 5-6: SIL 3 Function is met when contacts are in open state.

Contacts 7-8: Opening of contacts can be used for monitoring Contacts 5-6. No SIL Function.

Note: Contacts 3-4 and 7-8 can be connected in series for common monitoring.

Application for D1092D - Normally De-Energized Condition (ND) and one common driving signal from PLC for the two relays

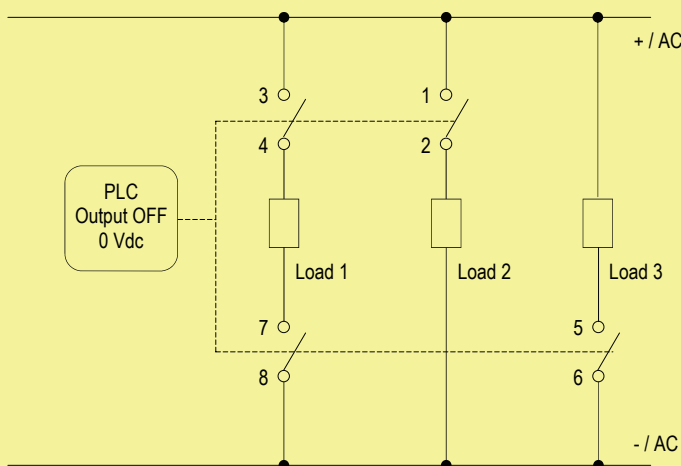

Contacts 1-2: Closing of contacts can be used for monitoring Contacts 3-4. No SIL Function.

Contacts 3-4: SIL 3 Function is met when contacts are in closed state.

Contacts 5-6: Closing of contacts can be used for monitoring Contacts 7-8. No SIL Function.

Contacts 7-8: SIL 3 Function is met when contacts are in closed state.

Note: Contacts 1-2 and 5-6 can be connected in series for common monitoring.

Warning

D1092 series are isolated electrical apparatus installed into standard EN50022 T35 DIN Rail located in Safe Area/Non Hazardous Locations or Zone 2, Group IIC, Temperature Classification T4, Class I, Division 2, Groups A, B, C, D, Temperature Code T4 and Class I, Zone 2, Group IIC, IIB, IIA Temperature Code T4 Hazardous Area/Hazardous Locations (according to EN/IEC60079-15, FM Class No. 3611, CSA-C22.2 No. 213-M1987, CSA-E60079-15) within the specified operating temperature limits Tamb -20 to +60 °C, and connected to equipment with a maximum limit for AC power supply of 250 Vrms.

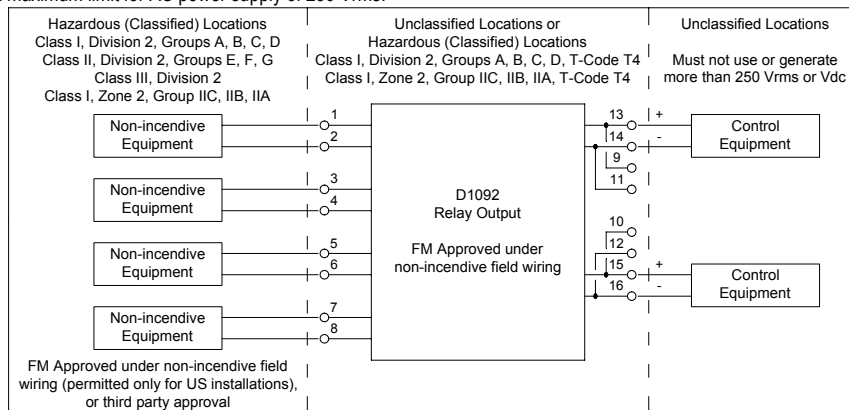

Non-incendive field wiring is not recognized by the Canadian Electrical Code, installation is permitted in the US only.

For installation of the unit in a Class I, Division 2 or Class I, Zone 2 location, the wiring between the control equipment and the D1092 electrical apparatus shall be accomplished via conduit connections or another acceptable Division 2, Zone 2 wiring method according to the NEC and the CEC.

Not to be connected to control equipment that uses or generates more than 250 Vrms or Vdc with respect to earth ground.

D1092 series must be installed, operated and maintained only by qualified personnel, in accordance to the relevant national/international installation standards (e.g. IEC/EN60079-14 Electrical apparatus for explosive gas atmospheres - Part 14: Electrical installations in hazardous areas (other than mines), BS 5345 Pt4, VDE 165, ANSI/ISA RP12.06.01 Installation of Intrinsically Safe System for Hazardous (Classified) Locations, National Electrical Code NEC ANSI/NFPA 70 Section 504 and 505, Canadian Electrical Code CEC) following the established installation rules.

De-energize power source (turn off power supply voltage) before plug or unplug the terminal blocks when installed in Hazardous Area/ Hazardous Locations or unless area is known to be nonhazardous.

Warning: substitution of components may impair Intrinsic Safety and suitability for Division 2, Zone 2.

Warning: de-energize main power source (turn off power supply voltage) and disconnect plug-in terminal blocks before opening the enclosure to avoid electrical shock when connected to live hazardous potential.

Explosion Hazard: to prevent ignition of flammable or combustible atmospheres, disconnect power before servicing or unless area is known to be nonhazardous.

Failure to properly installation or use of the equipment may risk to damage the unit or severe personal injury.

The unit cannot be repaired by the end user and must be returned to the manufacturer or his authorized representative. Any unauthorized modification must be avoided.

Operation

D1092 relay modules are suitable for the switching of safety related circuits, providing isolation between the input and output contacts. D1092S provides 1 SPST contact for normally energized (NE) loads and 1 SPST contact for normally de-energized (ND) loads. D1092D provides 2 SPST contacts for normally energized (NE) loads and 2 SPST contacts for normally de-energized (ND) loads. The channels and the relay contacts are completely isolated.

For each channel, a "RELAY STATUS" yellow led lights when input is powered, showing that relay is energized and relay output contacts are closed.

Installation

D1092 series are relay output modules housed in a plastic enclosure suitable for installation on T35 DIN Rail according to EN50022.

D1092 unit can be mounted with any orientation over the entire ambient temperature range, see section "Installation in Cabinet" and "Installation of Electronic Equipments in Cabinet" Instruction Manual D1000 series for detailed instructions.

Electrical connection of conductors up to 2.5 mm² are accommodated by polarized plug-in removable screw terminal blocks which can be plugged in/out into a powered unit without suffering or causing any damage (for Zone 2 or Division 2 installations check the area to be nonhazardous before servicing).

The wiring cables have to be proportionate in base to the current and the length of the cable.

On the section "Function Diagram" and enclosure side a block diagram identifies all connections.

Identify the number of channels of the specific card (e.g. D1092S is a single channel model and D1092D is a dual channel model), the function and location of each connection terminal using the wiring diagram on the corresponding section, as an example:

For Model D1092S connect positive input of channel 1 at terminal "13" and negative input at "14".

For Model D1092D in addition to channel 1 connections above, connect positive input of channel 2 at terminal "15" and negative input at "16".

For Model D1092D is also possible to control both channels with the same input (of channel 1 or 2), connecting a wired jumper between terminals "9" and "10" (for positive input duplication) and a wired jumper between terminals "11" and "12" (for negative input duplication).

For Model D1092S, in case of NE loads, the terminals "1" and "2" are the two poles of relay output contact used to enable or disable the load circuit. Generally, the relay contact is used to break positive or negative supply line of load circuit. Therefore, connect wire of supply line at terminal "1" and link another wire at terminal "2" to continue the supply line of load circuit. Considering always NE loads, for Model D1092D in addition to channel 1 connections above, use terminals "5" and "6" of channel 2 as two poles of relay output contact used to enable or disable the second load circuit.

For Model D1092S, in case of ND loads, the terminals "3" and "4" are the two poles of relay output contact used to enable or disable the load circuit. Generally, the relay contact is used to break positive or negative supply line of load circuit. Therefore, connect wire of supply line at terminal "3" and link another wire at terminal "4" to continue the supply line of load circuit. Considering always ND loads, for Model D1092D in addition to channel 1 connections above, use terminals "7" and "8" of channel 2 as two poles of relay output contact used to enable or disable the second load circuit.

Installation and wiring must be in accordance to the relevant national or international installation standards (e.g. IEC/EN60079-14 Electrical apparatus for explosive gas atmospheres - Part 14: Electrical installations in hazardous areas (other than mines), BS 5345 Pt4, VDE 165, ANSI/ISA RP12.06.01 Installation of Intrinsically Safe System for Hazardous (Classified) Locations, National Electrical Code NEC ANSI/NFPA 70 Section 504 and 505, Canadian Electrical Code CEC), make sure that conductors are well isolated from each other and do not produce any unintentional connection.

Connect SPST relay contacts checking the load rating to be within the contact maximum rating (3 A, 250 Vac or 125 Vdc, 750 VA 120 W resistive load).

If necessary, to prevent relay contacts from damaging, an external protection (fuse or similar) should be connected.

A suitable protection must be chosen according to the relay breaking capacity diagram on data sheet.

The enclosure provides, according to EN60529, an IP20 minimum degree of mechanical protection (or similar to NEMA Standard 250 type 1) for indoor installation, outdoor installation requires an additional enclosure with higher degree of protection (i.e. IP54 to IP65 or NEMA type 12-13) consistent with the effective operating environment of the specific installation.

Units must be protected against dirt, dust, extreme mechanical (e.g. vibration, impact and shock) and thermal stress, and casual contacts.

If enclosure needs to be cleaned use only a cloth lightly moistened by a mixture of detergent in water.

Electrostatic Hazard: to avoid electrostatic hazard, the enclosure of D1092 must be cleaned only with a damp or antistatic cloth.

Any penetration of cleaning liquid must be avoided to prevent damage to the unit. Any unauthorized card modification must be avoided.

Relay output contact must be connected to loads non exceeding category I, pollution degree 1 overvoltage limits.

Warning: de-energize main power source (turn off power supply voltage) and disconnect plug-in terminal blocks before opening the enclosure to avoid electrical shock when connected to live hazardous potential.

Start-up

Before powering the inputs of unit check that all wires are properly connected, also verifying their polarity. Check conductors for exposed wires that could touch each other causing dangerous unwanted shorts. Enabling each input, the corresponding "RELAY STATUS" yellow led must be lit and load circuit must be energized because relay output contact is closed. Indeed, disabling each input, the corresponding "RELAY STATUS" yellow led must be turned off and load circuit must be de-energized because relay output contact is open.

Installation in Cabinet

Power Dissipation of D1092 Isolators



Section "Technical Data" of D1092 isolator specifies the current consumption (maximum current from the nominal power supply, typical 24 Vdc, in normal operation); this data serves to dimension the current rating of the power supply unit. Section "Technical Data" indicates also the maximum power consumption (maximum power required from the power supply in the worst (abnormal) operating conditions like for example supply voltage at 30 Vdc, short circuit on the outputs and on the inputs terminals.

The power dissipated P_d inside the enclosure for analog signal isolators is: $P_d = \text{Current Consumption (A)} * \text{Supply Voltage (V)} - \text{Power Dissipated into the input/output loads}$
Analog signal isolators have higher dissipation than digital signal isolators, in addition 2 channels barriers (D1092D) have higher dissipation than single channel units (D1092S).

In analog signal isolators each transmitter requires and dissipates $15 \text{ V} * 0.02 \text{ A} = 0.3 \text{ W}$. Usually the loads outside the isolator dissipate 1/3 of the total power used. Isolators are not running at the maximum current all at the same time, the average power consumption of a multitude of isolators can be considered to be only 70 % of the value obtained from the section "Technical Data". Considering the 1/3 load power and the 70 % above discussed, the power effectively dissipated internally by the isolators can therefore become 1/2 of the actual power delivered by the power supply. Digital barriers dissipate all the supply power inside the enclosure consequently the total power dissipation into a cabinet, with mixed analog and digital barriers, is determined by the number of channels more than by the number of isolator enclosures. The following tables give advises for the DIN rail orientation (vertical or horizontal) of the barriers mounting, D1092D (double channel) and D1092S (single channel) isolators, installed on DIN rail, bus or custom board assembly.

A) Cabinet with Natural Ventilation

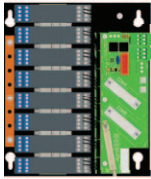
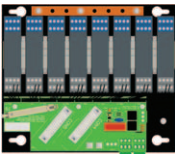

Maximum recommended ambient temperature in °C depending on barrier type and installation method:

Type of Isolator	Single unit Installation Any orientation	Installation of Multiple units with DIN-rail Bus		Installation on Custom Boards	
		Vertical	Horizontal	Vertical	Horizontal
					
D1092S	60°C	30°C	35°C	35°C	40°C
D1092D	60°C	Not recommended ⁽¹⁾	30°C	30°C	35°C

⁽¹⁾ Installation is not recommended since it would significantly shorten the units life and increase the probability of failures.

B) Cabinet with Forced Ventilation

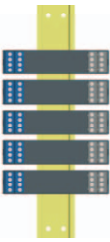
Maximum recommended ambient temperature in °C depending on barrier type and installation method:

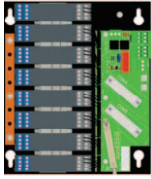
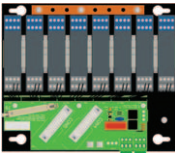
Type of Isolator	Single unit Installation Any orientation	Installation of Multiple units with DIN-rail Bus		Installation on Custom Boards	
		Vertical	Horizontal	Vertical	Horizontal
					
D1092S	60°C	40°C	45°C	45°C	50°C
D1092D	60°C	40°C	45°C	45°C	50°C