



# INSTRUCTION MANUAL

SIL 3 Repeater Power Supply  
Smart-Hart compatible  
DIN-Rail Models D1010S, D1010D

## SIL Applications

For Safety Related System and SIL2, SIL3 Applications according IEC61508 & IEC61511 Standards refer to "Functional Safety Manual" document number ISM0071

## Characteristics

**General Description:** The single and dual channel DIN Rail Repeater Power Supply, D1010S and D1010D, provides a fully floating dc supply for energizing conventional 2 wires 4-20 mA transmitters, or separately powered 3, 4 wires 4-20, 0-20 mA transmitters located in Hazardous Area, and repeats the current in floating circuit to drive a Safe Area load. The circuit allows bi-directional communication signals, for Hart-Smart transmitters.

**Function:** 1 or 2 channels I.S. analog input for 2 wires loop powered or separately powered Smart transmitters, provides 3 port isolation (input/output/supply) and current (source or sink) or voltage output signal.

**Signalling LED:** Power supply indication (green).

**Field Configurability:** mA (source or sink) or V output signal.

**Smart Communication Frequency Band:** 0.5 to 40 KHz within 3 dB (Hart and higher frequency protocols).

**EMC:** Fully compliant with CE marking applicable requirements.

## Technical Data

**Supply:** 24 Vdc nom (20 to 30 Vdc) reverse polarity protected, ripple within voltage limits  $\leq 5$  Vpp.

**Current consumption @ 24 V:** 115 mA for 2 channels D1010D, 60 mA for 1 channel D1010S with 20 mA output typical.

**Power dissipation:** 1.9 W for 2 channels D1010D, 1.0 W for 1 channel D1010S with 24 V supply voltage and 20 mA output typical.

**Max. power consumption:** at 30 V supply voltage and short circuit condition, 3.7 W for 2 channels D1010D, 2.0 W for 1 channel D1010S.

**Isolation (Test Voltage):** I.S. In/Out 1.5 KV; I.S. In/Supply 1.5 KV; I.S. In/I.S. In 500 V; Out/Supply 500 V; Out/Out 500 V.

**Input:** 0/4 to 20 mA (separately powered input, voltage drop  $\leq 0.9$  V) or 4 to 20 mA (2 wire Tx current limited at  $\approx 25$  mA).

**Transmitter line voltage:**  $\geq 15.0$  V at 20 mA with max. 20 mVrms ripple on 0.5 to 40 KHz frequency band.

**Output:** 0/4 to 20 mA, on max. 600  $\Omega$  load in source mode; V min. 5 V at 0  $\Omega$  load V max. 30 V in sink mode, current limited at  $\approx 23$  mA or 0/1 to 5 V on internal 250  $\Omega$  shunt (or 0/2 to 10 V on internal 500  $\Omega$  shunt on request).

**Response time:** 50 ms (10 to 90 % step change).

**Output ripple:**  $\leq 20$  mVrms on 250  $\Omega$  communication load on 0.5 to 40 KHz band.

**Frequency response:** 0.5 to 40 KHz bidirectional within 3 dB (Hart and higher frequency protocols).

**Performance:** Ref. Conditions 24 V supply, 250  $\Omega$  load, 23  $\pm 1$  °C ambient temperature.

**Calibration accuracy:**  $\leq \pm 0.1$  % of full scale.

**Linearity error:**  $\leq \pm 0.05$  % of full scale.

**Supply voltage influence:**  $\leq \pm 0.05$  % of full scale for a min to max supply change.

**Load influence:**  $\leq \pm 0.05$  % of full scale for a 0 to 100 % load resistance change.

**Temperature influence:**  $\leq \pm 0.01$  % on zero and span for a 1 °C change.

### Compatibility:



CE mark compliant, conforms to 94/9/EC Atex Directive and to 2004/108/CE EMC Directive.

**Environmental conditions: Operating:** temperature limits -20 to +60 °C, relative humidity max 90 % non condensing, up to 35 °C.

**Storage:** temperature limits -45 to +80 °C.



### Safety Description:

II (1) G [Ex ia Ga] IIC, II (1) D [Ex ia Da] IIIC, I (M1) [Ex ia Ma] I, II 3G Ex nA II T4, [Ex ia Ga] IIC, [Ex ia Da] IIIC, [Ex ia Ma] I associated electrical apparatus.

Uo/Voc = 26.3 V, Io/Isc = 91 mA, Po/Po = 597 mW at terminals 14-15, 10-11. Uo/Voc = 1.1 V, Io/Isc = 38 mA, Po/Po = 11 mW at terminals 15-16, 11-12.

Ui/Vmax = 30 V, li/lmax = 104 mA, Ci = 1.05 nF, Li = 0 nH at terminals 15-16, 11-12. Um = 250 Vrms, -20 °C  $\leq$  Ta  $\leq$  60 °C.

**Approvals:** DMT 01 ATEX E 042 X conforms to EN60079-0, EN60079-11, EN60079-26, EN61241-0, EN61241-11,

IECEx BVS 07.0027X conforms to IEC60079-0, IEC60079-11, IEC60079-26, IEC61241-0, IEC61241-11, IMQ 09 ATEX 013 X conforms to EN60079-0, EN60079-15,

UL & C-UL E222308 conforms to UL913 (Div.1), UL 60079-0 (General, All Zones), UL60079-11 (Intrinsic Safety "i" Zones 0 & 1), UL60079-15 ("n" Zone 2), UL 1604 (Div.2) for UL and

CSA-C22.2 No.157-92 (Div.1), CSA-E60079-0 (General, All Zones), CSA-E60079-11 (Intrinsic Safety "i" Zones 0 & 1), CSA-C22.2 No. 213-M1987 (Div. 2) and

CSA-E60079-15 ("n" Zone 2) for C-UL, refer to control drawing ISM0125 for complete UL and C-UL safety and installation instructions.

FM & FM-C No. 3024643, 3029921C, conforms to Class 3600, 3610, 3611, 3810 and C22.2 No.142, C22.2 No.157, C22.2 No.213, E60079-0, E60079-11, E60079-15,

Russia according to GOST 12.2.007.0-75, R 51330.0-99, R 51330.10-99 [Exia] IIC X, Ukraine according to GOST 12.2.007.0,22782.0,22782.5 Exia IIC X,

TUV Certificate No. C-IS-183645-01, SIL 2 / SIL 3 according to IEC 61508. Please refer to Functional Safety Manual for SIL applications.

DNV and KR Type Approval Certificate for marine applications.

**Mounting:** T35 DIN Rail according to EN50022.

**Weight:** about 175 g D1010D, 125 g D1010S.

**Connection:** by polarized plug-in disconnect screw terminal blocks to accommodate terminations up to 2.5 mm<sup>2</sup>.

**Location:** Safe Area/Non Hazardous Locations or Zone 2, Group IIC T4, Class I, Division 2, Groups A, B, C, D Temperature Code T4 and Class I, Zone 2, Group IIC, IIB, IIA T4 installation.

**Protection class:** IP 20.

**Dimensions:** Width 22.5 mm, Depth 99 mm, Height 114.5 mm.

## Ordering information

Model:	D1010			
1 channel		S		
2 channels		D		
Power Bus enclosure			/B	

## Front Panel and Features

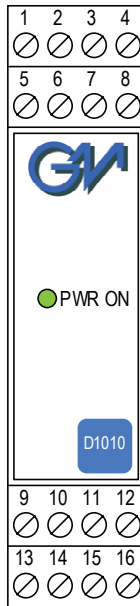

- SIL 3 according to IEC 61508 for Tproof = 1 year (20 % of total SIF).
- SIL 2 according to IEC 61508 for Tproof = 5 / 10 years (10 / 20 % of total SIF).
- PFDavg (1 year) 1.50 E-04, SFF 91.85 %.
- Input from Zone 0 (Zone 20), Division 1, installation in Zone 2, Division 2.
- 4-20 or 0-20 mA Input, Output Signal.
- Wide Band Smart Communication, Hart compatible.
- Input and Output short circuit proof.
- High Accuracy.
- Three port isolation, Input/Output/Supply.
- EMC Compatibility to EN61000-6-2, EN61000-6-4.
- In-field programmability by DIP Switch.
- ATEX, IECEx, UL & C-UL, FM & FM-C, Russian and Ukrainian Certifications.
- Type Approval Certificate DNV and KR for marine applications.
- High Reliability, SMD components.
- High Density, two channels per unit.
- Simplified installation using standard DIN Rail and plug-in terminal blocks.
- 250 Vrms (Um) max. voltage allowed to the instruments associated with the barrier.

## Terminal block connections

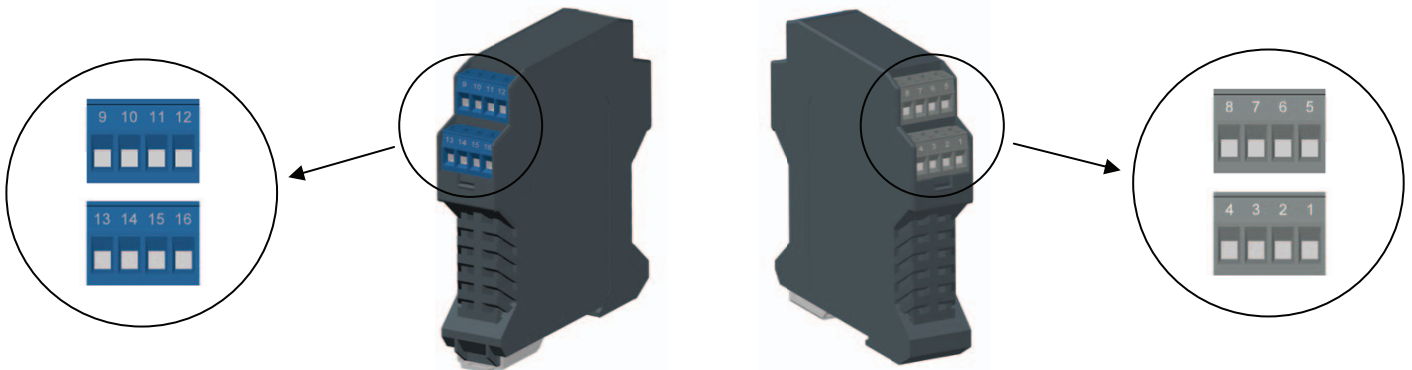

### HAZARDOUS AREA

<b>9</b>	Not used
<b>10</b>	+ Input Ch 2 for 2 wire Transmitters
<b>11</b>	- Input Ch 2 for 2 wire Transmitters or + Input Ch 2 for External Powered Transmitters
<b>12</b>	- Input Ch 2 for External Powered Transmitters
<b>13</b>	Not used
<b>14</b>	+ Input Ch 1 for 2 wire Transmitters
<b>15</b>	- Input Ch 1 for 2 wire Transmitters or + Input Ch 1 for External Powered Transmitters
<b>16</b>	- Input Ch 1 for External Powered Transmitters

### SAFE AREA

<b>1</b>	+ Output Ch 1 for Current Source mode or + Output Ch 1 for Voltage Source mode
<b>2</b>	- Output Ch 1 for Current Source mode or - Output Ch 1 for Voltage Source mode or + Output Ch 1 for Current Sink mode
<b>3</b>	+ Power Supply 24 Vdc
<b>4</b>	- Power Supply 24 Vdc
<b>5</b>	+ Output Ch 2 for Current Source mode or + Output Ch 2 for Voltage Source mode
<b>6</b>	- Output Ch 2 for Current Source mode or - Output Ch 2 for Voltage Source mode or + Output Ch 2 for Current Sink mode
<b>7</b>	- Output Ch 2 for Current Sink mode
<b>8</b>	- Output Ch 1 for Current Sink mode

## Parameters Table

In the system safety analysis, always check the Hazardous Area/Hazardous Locations devices to conform with the related system documentation, if the device is Intrinsically Safe check its suitability for the Hazardous Area/Hazardous Locations and gas group encountered and that its maximum allowable voltage, current, power ( $U_i/V_{max}$ ,  $I_i/I_{max}$ ,  $P_i/P_i$ ) are not exceeded by the safety parameters ( $U_o/V_o$ ,  $I_o/I_o$ ,  $P_o/P_o$ ) of the D1010 series Associated Apparatus connected to it. Also consider the maximum operating temperature of the field device, check that added connecting cable and field device capacitance and inductance do not exceed the limits ( $C_o/C_a$ ,  $L_o/L_a$ ,  $L_o/R_o$ ) given in the Associated Apparatus parameters for the effective gas group. See parameters on enclosure side and the ones indicated in the table below:

D1010 Terminals		D1010 Associated Apparatus Parameters		Must be	Hazardous Area/ Hazardous Locations Device Parameters
Ch1	14 - 15	$U_o / V_o = 26.3 \text{ V}$		$\leq$	$U_i / V_{max}$
Ch2	10 - 11				
Ch1	15 - 16	$U_o / V_o = 1.1 \text{ V}$			
Ch2	11 - 12				
Ch1	14 - 15	$I_o / I_o = 91 \text{ mA}$		$\leq$	$I_i / I_{max}$
Ch2	10 - 11				
Ch1	15 - 16	$I_o / I_o = 38 \text{ mA}$			
Ch2	11 - 12				
Ch1	14 - 15	$P_o / P_o = 597 \text{ mW}$		$\leq$	$P_i / P_i$
Ch2	10 - 11				
Ch1	15 - 16	$P_o / P_o = 11 \text{ mW}$			
Ch2	11 - 12				
D1010 Terminals		D1010 Associated Apparatus Parameters		Must be	Hazardous Area/ Hazardous Locations Device + Cable Parameters
Ch1	14 - 15	$C_o / C_a = 95 \text{ nF}$ $C_o / C_a = 738 \text{ nF}$	(IIC-A, B) (IIB-C)	$\geq$	$C_i / C_i \text{ device} + C \text{ cable}$
Ch2	10 - 11				
Ch1	15 - 16	$C_o / C_a = 100 \mu\text{F}$ $C_o / C_a = 1000 \mu\text{F}$	(IIC-A, B) (IIB-C)		
Ch2	11 - 12				
Ch1	14 - 15	$L_o / L_a = 4.3 \text{ mH}$ $L_o / L_a = 17.2 \text{ mH}$	(IIC-A, B) (IIB-C)	$\geq$	$L_i / L_i \text{ device} + L \text{ cable}$
Ch2	10 - 11				
Ch1	15 - 16	$L_o / L_a = 11.3 \text{ mH}$ $L_o / L_a = 45.3 \text{ mH}$	(IIC-A, B) (IIB-C)		
Ch2	11 - 12				
Ch1	14 - 15	$L_o / R_o = 59.6 \mu\text{H}/\Omega$ $L_o / R_o = 238.4 \mu\text{H}/\Omega$	(IIC-A, B) (IIB-C)	$\geq$	$L_i / R_i \text{ device and}$ $L \text{ cable} / R \text{ cable}$
Ch2	10 - 11				
Ch1	15 - 16	$L_o / R_o = 3490 \mu\text{H}/\Omega$ $L_o / R_o = 13963 \mu\text{H}/\Omega$	(IIC-A, B) (IIB-C)		
Ch2	11 - 12				

NOTE for USA and Canada:  
IIC equal to Gas Groups A, B, C, D, E, F and G,  
IIB equal to Gas Groups C, D, E, F and G,  
IIA equal to Gas Groups D, E, F and G

When used with separate powered intrinsically safe devices, check that maximum allowable voltage, current ( $U_i/V_{max}$ ,  $i_i/I_{max}$ ) of the D1010 Associated Apparatus are not exceeded by the safety parameters ( $U_o/V_{oc}$ ,  $I_o/I_{sc}$ ) of the Intrinsically Safe device, indicated in the table below:

D1010 Terminals		D1010 Associated Apparatus Parameters	Must be	Hazardous Area/ Hazardous Locations Device Parameters
Ch1	15 - 16	$U_i / V_{max} = 30V$	$\geq$	$U_o / V_{oc}$
Ch2	11 - 12			
Ch1	15 - 16	$i_i / I_{max} = 104 \text{ mA}$	$\geq$	$I_o / I_{sc}$
Ch2	11 - 12			
Ch1	15 - 16	$C_i = 1.05 \text{ nF}$ , $L_i = 0 \text{ nH}$		
Ch2	11 - 12			

**For installations in which both the  $C_i$  and  $L_i$  of the Intrinsically Safe apparatus exceed 1 % of the  $C_o$  and  $L_o$  parameters of the Associated Apparatus (excluding the cable), then 50 % of  $C_o$  and  $L_o$  parameters are applicable and shall not be exceeded** (50 % of the  $C_o$  and  $L_o$  become the limits which must include the cable such that  $C_i \text{ device} + C \text{ cable} \leq 50 \% \text{ of } C_o$  and  $L_i \text{ device} + L \text{ cable} \leq 50 \% \text{ of } L_o$ ).

If the cable parameters are unknown, the following value may be used: Capacitance 60pF per foot (180pF per meter), Inductance 0.20 $\mu$ H per foot (0.60 $\mu$ H per meter).

The Intrinsic Safety Entity Concept allows the interconnection of Intrinsically Safe devices approved with entity parameters not specifically examined in combination as a system when the above conditions are respected.

For Division 1 and Zone 0 installations, the configuration of Intrinsically Safe Equipment must be FM approved under Entity Concept (or third party approved);

for Division 2 installations, the configuration of Intrinsically Safe Equipment must be FM approved under non-incendive field wiring or Entity Concept (or third party approved).

## Function Diagram

HAZARDOUS AREA ZONE 0 (ZONE 20) GROUP IIC,  
HAZARDOUS LOCATIONS CLASS I, DIVISION 1, GROUPS A, B, C, D,  
CLASS II, DIVISION 1, GROUPS E, F, G, CLASS III, DIVISION 1,  
CLASS I, ZONE 0, GROUP IIC

SAFE AREA, ZONE 2 GROUP IIC T4,  
NON HAZARDOUS LOCATIONS, CLASS I, DIVISION 2,  
GROUPS A, B, C, D T-Code T4, CLASS I, ZONE 2, GROUP IIC T4

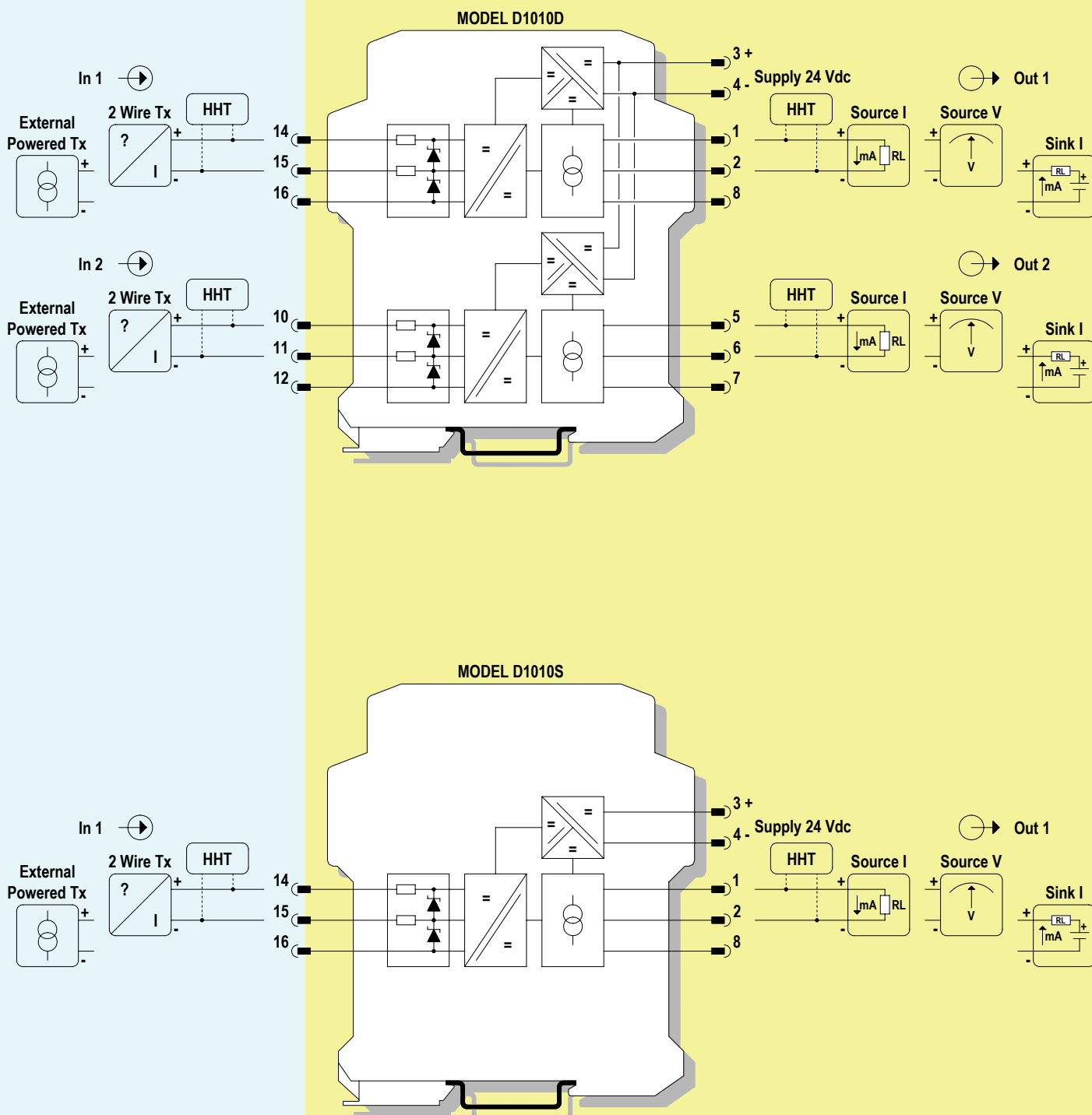

## Function Diagram

HAZARDOUS AREA ZONE 0 (ZONE 20) GROUP IIC,  
HAZARDOUS LOCATIONS CLASS I, DIVISION 1, GROUPS A, B, C, D,  
CLASS II, DIVISION 1, GROUPS E, F, G, CLASS III, DIVISION 1,  
CLASS I, ZONE 0, GROUP IIC

SAFE AREA, ZONE 2 GROUP IIC T4,  
NON HAZARDOUS LOCATIONS, CLASS I, DIVISION 2,  
GROUPS A, B, C, D T-Code T4, CLASS I, ZONE 2, GROUP IIC T4

### Safety Description

Terminals 14-11  
(with 15-12 shorted)  
 $U_o/V_{oc} = 27.4 \text{ V}$   
 $I_o/I_{sc} = 91 \text{ mA}$   
 $P_o/P_o = 624 \text{ mW}$

Group	Co/Ca ( $\mu\text{F}$ )	Lo/La (mH)	Lo/Ro ( $\mu\text{H}/\Omega$ )
Cenelec			
IIC	0.085	4.3	54.7
IIB	0.675	17.2	218.9
IIA	2.258	34.5	437.9

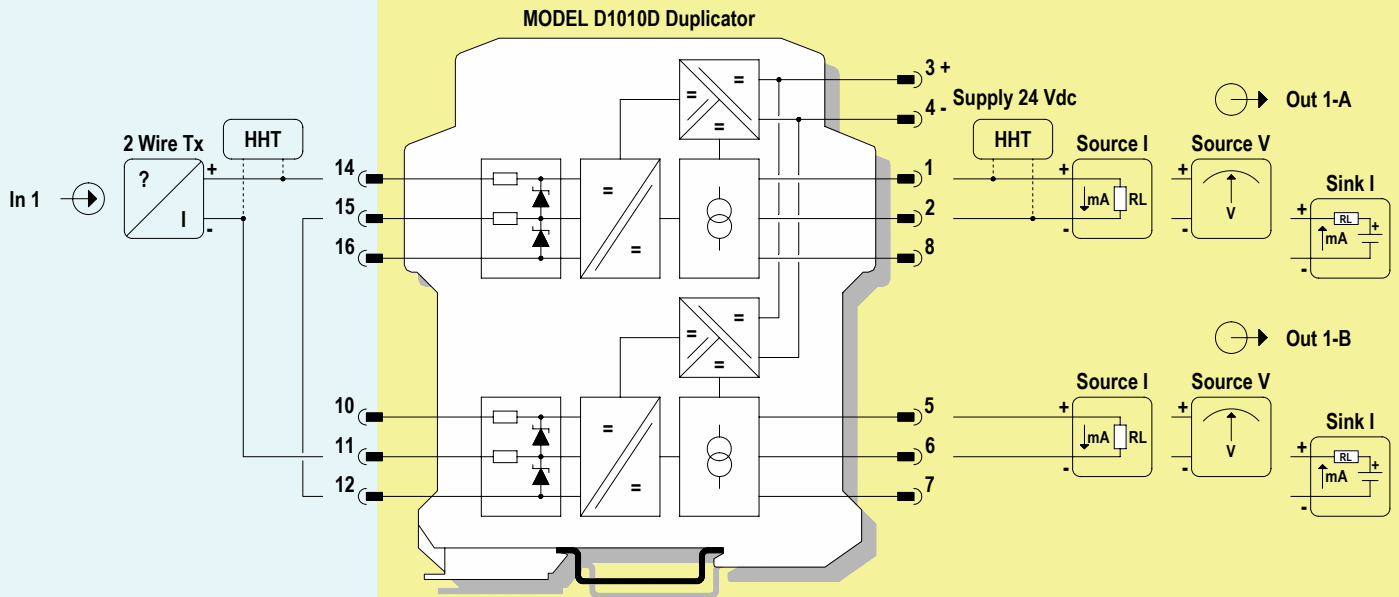

### Connections for Duplication of 2 wires Transmitter Input

Restriction on specifications for 2 wires Transmitter Input:

Bidirectional communication for Smart Transmitter is provided only on channel 1

The minimum supply voltage available for Transmitter ( $V_{tx}$ ) is 14.1 V at 20 mA input

The safety parameters must be changed in:  $U_o/V_{oc} = 27.4 \text{ V}$ ,  $I_o/I_{sc} = 91 \text{ mA}$ ,  $P_o/P_o = 624 \text{ mW}$

## Function Diagram

HAZARDOUS AREA ZONE 0 (ZONE 20) GROUP IIC,  
HAZARDOUS LOCATIONS CLASS I, DIVISION 1, GROUPS A, B, C, D,  
CLASS II, DIVISION 1, GROUPS E, F, G, CLASS III, DIVISION 1,  
CLASS I, ZONE 0, GROUP IIC

SAFE AREA, ZONE 2 GROUP IIC T4,  
NON HAZARDOUS LOCATIONS, CLASS I, DIVISION 2,  
GROUPS A, B, C, D T-Code T4, CLASS I, ZONE 2, GROUP IIC T4

### Safety Description

Terminals 15-12  
(with 16-11 shorted)  
 $U_o/V_{oc} = 2.2\text{ V}$   
 $I_o/I_{sc} = 38\text{ mA}$   
 $P_o/P_o = 21\text{ mW}$

Group	Co/Ca ( $\mu\text{F}$ )	Lo/La (mH)	Lo/Ro ( $\mu\text{H}/\Omega$ )
Cenelec IIC	100	11.3	849
IIB	1000	45.3	3396
IIA	1000	90.7	6793

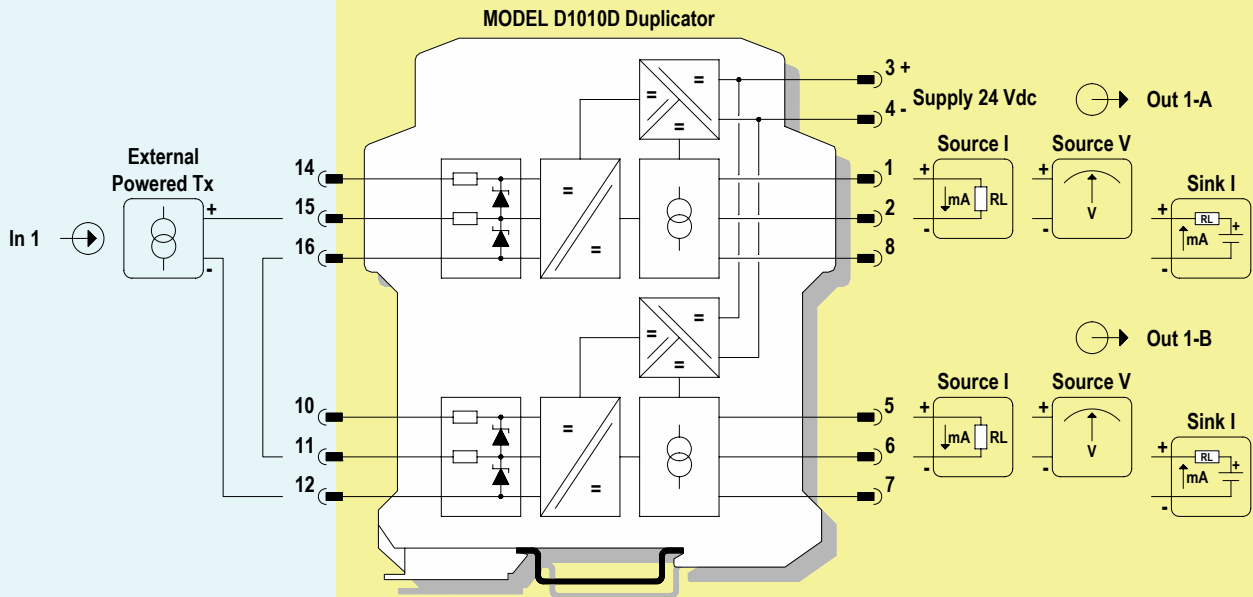

### Connections for Duplication of Active Input Signals

Restriction on specifications for externally powered Transmitter:

The voltage drop must be changed in 1.8 V maximum

The safety parameters must be changed in:  $U_o/V_{oc} = 2.2\text{ V}$ ,  $I_o/I_{sc} = 38\text{ mA}$ ,  $P_o/P_o = 21\text{ mW}$



## Warning

D1010 series are isolated Intrinsically Safe Associated Apparatus installed into standard EN50022 T35 DIN Rail located in Safe Area/ Non Hazardous Locations or Zone 2, Group IIC, Temperature Classification T4, Class I, Division 2, Groups A, B, C, D, Temperature Code T4 and Class I, Zone 2, Group IIC, IIB, IIA Temperature Code T4 Hazardous Area/Hazardous Locations (according to EN/IEC60079-15, FM Class No. 3611, CSA-C22.2 No. 213-M1987, CSA-E60079-15) within the specified operating temperature limits Tamb -20 to +60 °C, and connected to equipment with a maximum limit for AC power supply Um of 250 Vrms.

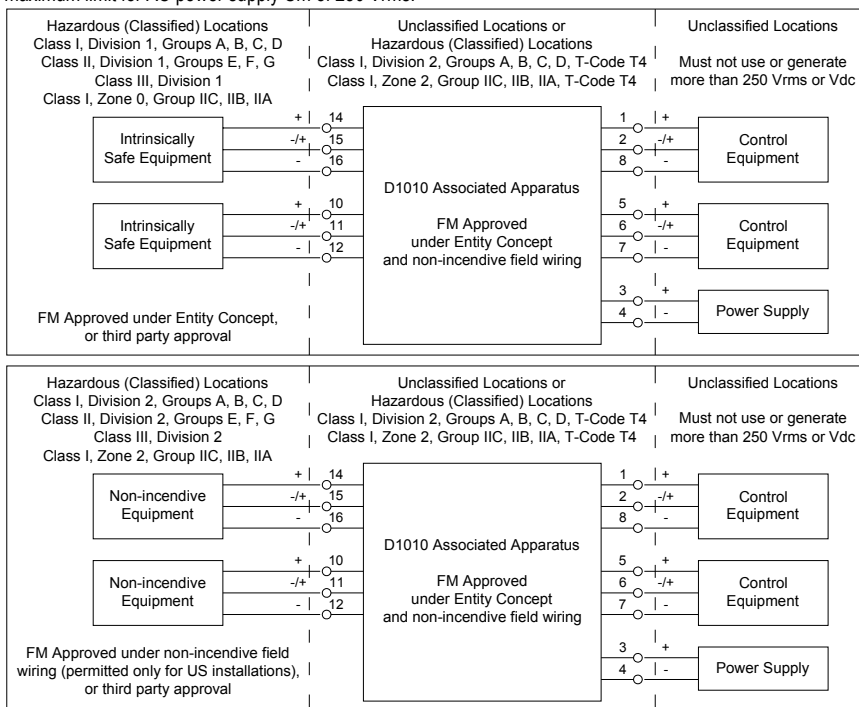

Non-incendive field wiring is not recognized by the Canadian Electrical Code, installation is permitted in the US only.

For installation of the unit in a Class I, Division 2 or Class I, Zone 2 location, the wiring between the control equipment and the D1010 associated apparatus shall be accomplished via conduit connections or another acceptable Division 2, Zone 2 wiring method according to the NEC and the CEC.

Not to be connected to control equipment that uses or generates more than 250 Vrms or Vdc with respect to earth ground.

D1010 series must be installed, operated and maintained only by qualified personnel, in accordance to the relevant national/international installation standards (e.g. IEC/EN60079-14 Electrical apparatus for explosive gas atmospheres - Part 14: Electrical installations in hazardous areas (other than mines), BS 5345 Pt4, VDE 165, ANSI/ISA RP12.06.01 Installation of Intrinsically Safe System for Hazardous (Classified) Locations, National Electrical Code NEC ANSI/NFPA 70 Section 504 and 505, Canadian Electrical Code CEC) following the established installation rules, particular care shall be given to segregation and clear identification of I.S. conductors from non I.S. ones. De-energize power source (turn off power supply voltage) before plug or unplug the terminal blocks when installed in Hazardous Area/Hazardous Locations or unless area is known to be nonhazardous.

**Warning: substitution of components may impair Intrinsic Safety and suitability for Division 2, Zone 2.**

**Explosion Hazard: to prevent ignition of flammable or combustible atmospheres, disconnect power before servicing or unless area is known to be nonhazardous.**

Failure to properly installation or use of the equipment may risk to damage the unit or severe personal injury.

The unit cannot be repaired by the end user and must be returned to the manufacturer or his authorized representative. Any unauthorized modification must be avoided.

## Operation

D1010 provides fully floating DC supply for energizing 2 wire 4-20 mA transmitters, or separately powered 3, 4 wire, 0/4-20 mA transmitters located in Hazardous Area, and repeats and converts the current to a 0/4-20 mA or 0/1-5 V floating output signal to drive a Safe Area load.

The circuit allows bi-directional communication signal for smart transmitters, a "POWER ON" green led lits when input power is present.

## Installation

D1010 series are repeater power supply smart/hart compatible housed in a plastic enclosure suitable for installation on T35 DIN Rail according to EN50022.

D1010 unit can be mounted with any orientation over the entire ambient temperature range, see section "Installation in Cabinet" and "Installation of Electronic Equipments in Cabinet" Instruction Manual D1000 series for detailed instructions.

Electrical connection of conductors up to 2.5 mm<sup>2</sup> are accommodated by polarized plug-in removable screw terminal blocks which can be plugged in/out into a powered unit without suffering or causing any damage **(for Zone 2 or Division 2 installations check the area to be nonhazardous before servicing)**.

The wiring cables have to be proportionate in base to the current and the length of the cable.

On the section "Function Diagram" and enclosure side a block diagram identifies all connections and configuration DIP switches.

Identify the number of channels of the specific card (e.g. D1010S is a single channel model and D1010D is a dual channel model), the function and location of each connection terminal using the wiring diagram on the corresponding section, as an example:

Connect 24 Vdc power supply positive at terminal "3" and negative at terminal "4".

For Model D1010S connect positive output of channel 1 (mA source mode) at terminal "1" and negative output at "2".

For Model D1010D in addition to channel 1 connections above, connect positive output of channel 2 at terminal "5" and negative output at "6".

For Model D1010S, in case of a 2 wire Transmitter, connect the wires at terminal "14" for positive and "15" for negative.

For separately powered Transmitters connect input signal at terminal "15" for positive and "16" for negative.

For Model D1010D in addition to channel 1 connections above, connect terminal "10" for positive and "11" for negative on channel 2.

Connect input signal from separately powered Transmitters at terminals "11" for positive and "12" for negative channel 2.

Intrinsically Safe conductors must be identified and segregated from non I.S. and wired in accordance to the relevant national/international installation standards (e.g. EN/IEC60079-14 Electrical apparatus for explosive gas atmospheres - Part 14: Electrical installations in hazardous areas (other than mines), BS 5345 Pt4, VDE 165, ANSI/ISA RP12.06.01 Installation of Intrinsically Safe System for Hazardous (Classified) Locations, National Electrical Code NEC ANSI/NFPA 70 Section 504 and 505, Canadian Electrical Code CEC), make sure that conductors are well isolated from each other and do not produce any unintentional connection.

The enclosure provides, according to EN60529, an IP20 minimum degree of mechanical protection (or similar to NEMA Standard 250 type 1) for indoor installation, outdoor installation requires an additional enclosure with higher degree of protection (i.e. IP54 to IP65 or NEMA type 12-13) consistent with the effective operating environment of the specific installation.

Units must be protected against dirt, dust, extreme mechanical (e.g. vibration, impact and shock) and thermal stress, and casual contacts.

If enclosure needs to be cleaned use only a cloth lightly moistened by a mixture of detergent in water.

**Electrostatic Hazard: to avoid electrostatic hazard, the enclosure of D1010 must be cleaned only with a damp or antistatic cloth.**

Any penetration of cleaning liquid must be avoided to prevent damage to the unit. Any unauthorized card modification must be avoided.

According to EN61010, D1010 series must be connected to SELV or SELV-E supplies.

## Start-up

Before powering the unit check that all wires are properly connected, particularly supply conductors and their polarity, input and output wires, also check that Intrinsically Safe conductors and cable trays are segregated (no direct contacts with other non I.S. conductors) and identified either by color coding, preferably blue, or by marking.

Check conductors for exposed wires that could touch each other causing dangerous unwanted shorts.

Turn on power, the "power on" green led must be lit, for 2 wire transmitter connection the supply voltage on each channel must be  $\geq 15\text{ V}$ , output signal should be corresponding to the

## Installation in Cabinet

### Power Dissipation of D1010 Isolators

Section "Technical Data" of D1010 isolator specifies the current consumption (maximum current from the nominal power supply, typical 24 Vdc, in normal operation); this data serves to dimension the current rating of the power supply unit. Section "Technical Data" indicates also the maximum power consumption (maximum power required from the power supply in the worst (abnormal) operating conditions like for example supply voltage at 30 Vdc, short circuit on the outputs and on the inputs terminals.

The power dissipated  $P_d$  inside the enclosure for analog signal isolators is:  $P_d = \text{Current Consumption (A)} * \text{Supply Voltage (V)} - \text{Power Dissipated into the input/output loads}$

Analog signal isolators have higher dissipation than digital signal isolators, in addition 2 channels barriers (D1010D) have higher dissipation than single channel units (D1010S).



In analog signal isolators each transmitter requires and dissipates  $15\text{ V} * 0.02\text{ A} = 0.3\text{ W}$ . Usually the loads outside the isolator dissipate 1/3 of the total power used.

Isolators are not running at the maximum current all at the same time, the average power consumption of a multitude of isolators can be considered to be only 70 % of the value obtained from the section "Technical Data". Considering the 1/3 load power and the 70 % above discussed, the power effectively dissipated internally by the isolators can therefore become 1/2 of the actual power delivered by the power supply.

Digital barriers dissipate all the supply power inside the enclosure consequently the total power dissipation into a cabinet, with mixed analog and digital barriers, is determined by the number of channels more than by the number of isolator enclosures. The following tables give advises for the DIN rail orientation (vertical or horizontal) of the barriers mounting, D1010D (double channel) and D1010S (single channel) isolators, installed on DIN rail, bus or custom board assembly.

### A) Cabinet with Natural Ventilation

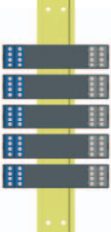

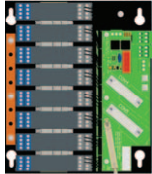
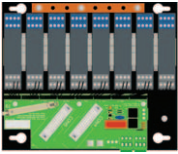
Maximum recommended ambient temperature in °C depending on barrier type and installation method:

Type of Isolator	Single unit Installation	Installation of Multiple units with DIN-rail Bus		Installation on Custom Boards	
	Any orientation	Vertical	Horizontal	Vertical	Horizontal
					
D1010S	60°C	30°C	35°C	35°C	40°C
D1010D	60°C	Not recommended <sup>(1)</sup>	30°C	30°C	35°C

<sup>(1)</sup> Installation is not recommended since it would significantly shorten the units life and increase the probability of failures.

### B) Cabinet with Forced Ventilation

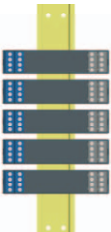
Maximum recommended ambient temperature in °C depending on barrier type and installation method:

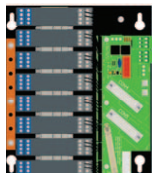
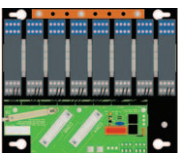
Type of Isolator	Single unit Installation	Installation of Multiple units with DIN-rail Bus		Installation on Custom Boards	
	Any orientation	Vertical	Horizontal	Vertical	Horizontal
					
D1010S	60°C	40°C	45°C	45°C	50°C
D1010D	60°C	40°C	45°C	45°C	50°C

## Configuration

An output configuration DIP Switch is located on component side of pcb, by closing switch "ON" (1-2 for channel 1, 3-4 for channel 2) output signal is configured for 0/1-5 Volts (250 W internal shunt), opening the switch produces the conventional 0/4-20 mA.

Side A Panel View

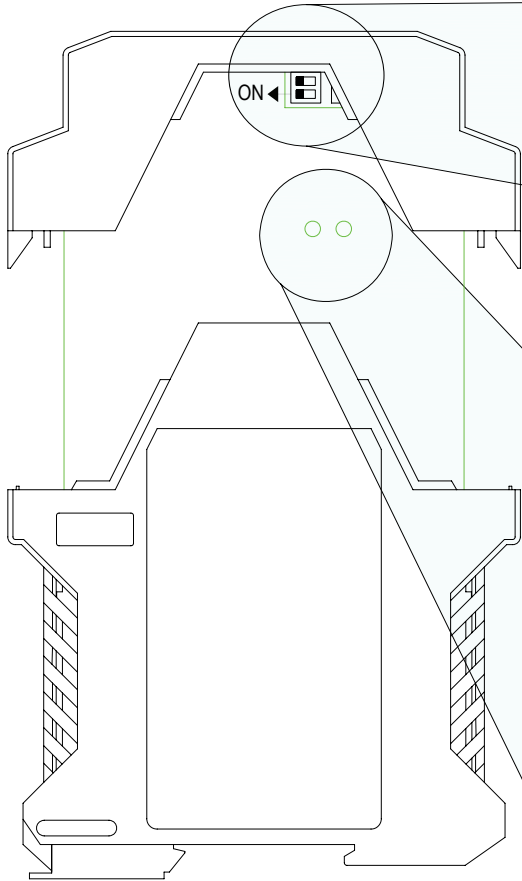

Dip switch configuration

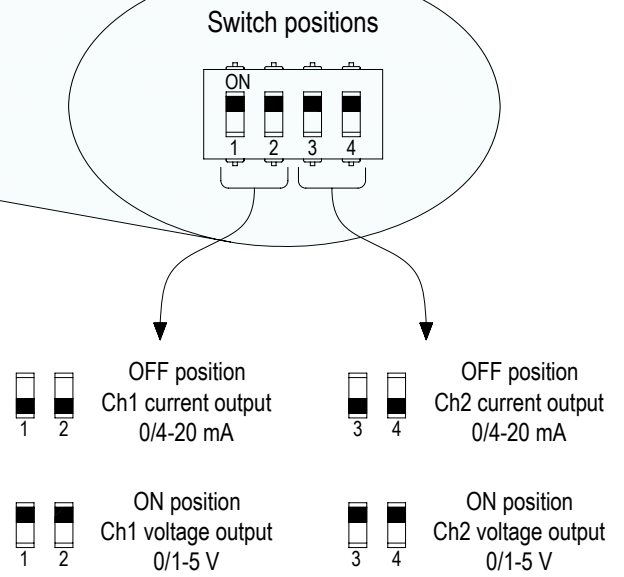

Side B Panel View

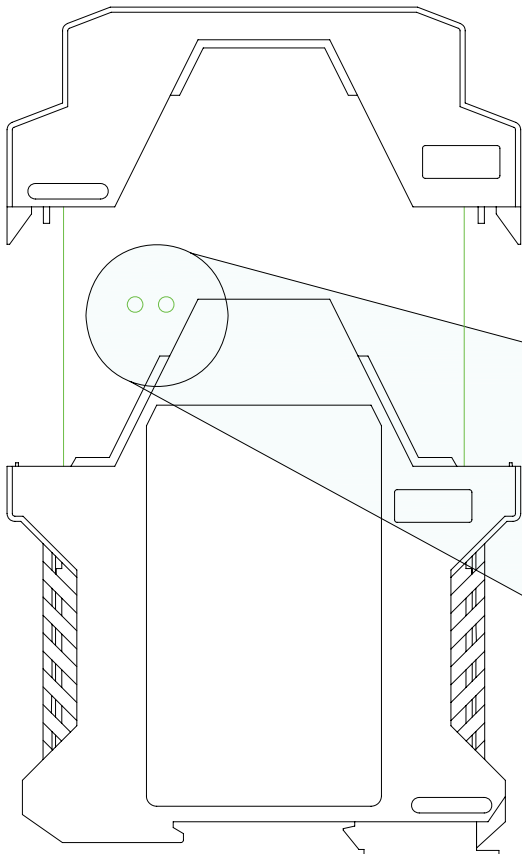

Span Trimmer CH1

Calibration Trimmer Ch1

Screwdriver  
for Trimmers  
1 x 0.5 mm



Turn the trimmer clockwise to  
Increase Output value or turn  
the trimmer counterclockwise  
if you want to decrease Output  
value.

Calibration Trimmer Ch2

Span Trimmer CH2

## Calibration instruction and Troubleshooting

In case a calibration check or readjustment is necessary the following equipment is required:

Equipment Required	Instrument	Identification
Adjustable Power Supply Range 0-35 V Resolution 0.1 V, Accuracy 1% Output Capability 200 mA	Agilent E3611A	PS
Current Meter range 20 mA, Resolution 1 $\mu$ A Accuracy 0.01% or Voltage Meter Range 10 V, Resolution 1 mV Accuracy 0.01%	Agilent 34410A	DMM
Voltage Meter range 30 V, Resolution 1 mV Accuracy 0.05 %	Fluke 175	V1
Current Calibrator range 20 mA, Resolution 1 $\mu$ A Accuracy 0.01 %	Yokogawa 7651	CAL

### (1) For current output please follow step 1

- Check that dip switch in the unit is in position "OFF" (see "Configuration" section). Connect the unit as shown below:

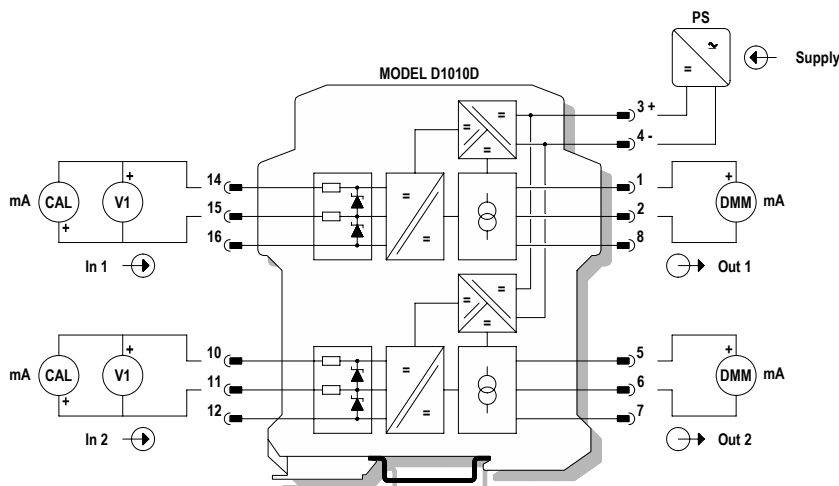

- Set power supply (PS) at 24.0 V at terminals 3 (+) and 4 (-), the calibrator (CAL) in the function "mA" 20 mA range at terminals 14 (-) and 15 (+), the multimeter (V1) for the reading in DC supply 30 V range at terminals 14 (+) and 15 (-), the multimeter (DMM) for the reading in DC supply 20 mA range at terminals 1 (+) and 2 (-).
- Execute the next test to verify D1010S unit channel or execute it twice to verified both D1010D unit channels.
- Verify that green led on the front panel is ON.

If the power ON Led is off, check supply voltage, polarity and wiring.

- Set calibrator (CAL) at 4.000 mA and verify that the output current, read by multimeter (DMM), is correspondent with a maximum deviation presented in the section "Technical Data".
- Set calibrator (CAL) at 20.000 mA and verify that the output current, read by multimeter (DMM), is correspondent with a maximum deviation presented in the section "Technical Data". If the maximum deviation is exceeded, repeat the board calibration and proceed in the following way:
  - Set the calibrator (CAL) at 20.000 mA and regulate the current, read by multimeter (DMM), by turning the span trimmer of the unit (see "Configuration" section) until reading  $20.000 \text{ mA} \pm 5 \mu\text{A}$  value.
  - To execute a linearity test: set the calibrator (CAL) at 4.000, 8.000, 12.000, 16.000, 20.000 mA and verify current output is correspondent with a maximum deviation presented in the section "Technical Data".
- Set calibrator (CAL) at 20.000 mA and power supply (PS) at 20.0 V; verify that multimeter (V1) reads input voltage as presented in the section "Technical Data".

### (2) For voltage output please follow step 2

- Check that dip switch in the unit is in position "ON" (see "Configuration" section). Connect the unit as shown below:

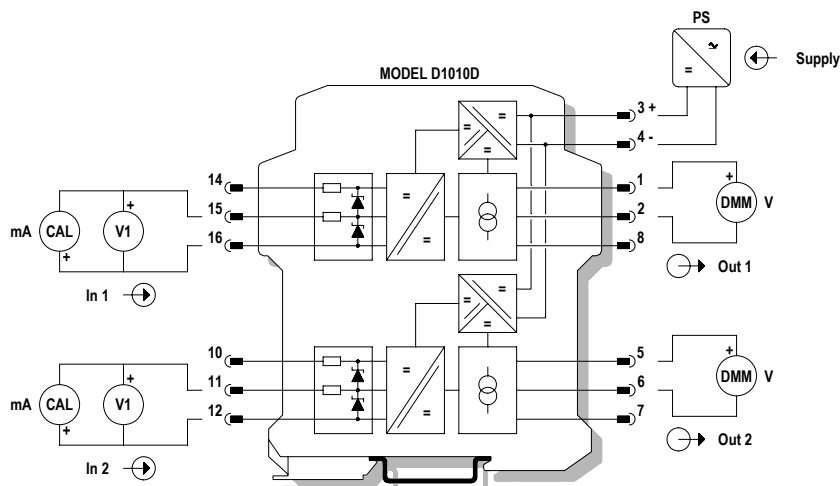

- Set multimeter (DMM) for the reading in DC supply, 10 V range.
- Set calibrator (CAL) at 20.000 mA and power supply (PS) at 20.0 V; verify that output voltage (20 mA current on the 250  $\Omega$  shunt resistance) read by multimeter (DMM) is  $5.000 \text{ V} \pm 10 \text{ mV}$ .