

**Characteristics:**

**General Description:**

The D5290S-080 is a relay module suitable for the switching of safety related circuits, up to SIL 3 level according to IEC 61508 for high risk industries. It provides isolation between input channel and output contacts. The input channel requires 115 Vac voltage signal to drive the relay coils. D5290S-080 provides two NO contacts for normally energized load and a NC contact for service purpose, in order to switch the NE load on both supply lines. See the following pages for Functional Safety applications with related SIL value.

Mounting on standard DIN-Rail in Safe Area.

**Technical Data:**

**Input:** 115 Vac nom (95 to 130 Vac).

**Current consumption @ 115 Vac:** 25 mA with relay energized, typical.

**Power dissipation:** 2.5 W with 115 Vac input voltage, relay energized, typical.

**Isolation (Test Voltage):** Input / All Outputs: 2.5 KV ; Out 1 / Out 2: 500 V.

**Output:** 1 voltage free SPDT relay contact identified with outputs: Out 1 (NO contact) terminals 13-21 and Service Load Out (NC contact) terminals 13-15; 1 voltage free SPST relay contact identified with output Out 2 (NO contact) terminals 14-22.

Terminals 13-21 (Out 1) and 14-22 (Out 2) are open when relay is de-energized, closed in energized relay condition.

Service load output (not SIL) at terminals 13-15 is normally close when relay is de-energized, open in energized relay condition.

**Contact material:** Ag Alloy (Cd free).

**Contact rating:** 10 A 250 Vac 2500 VA, 10 A 250 Vdc 300 W (resistive load).

**DC Load breaking capacity:**

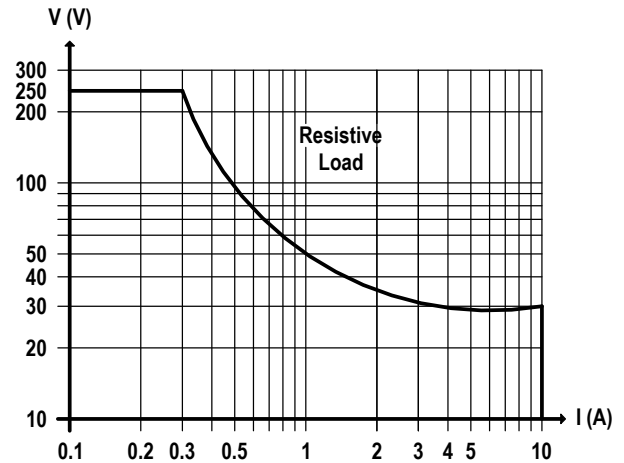

**Mechanical / Electrical life:** 5 \* 10<sup>6</sup> / 5 \* 10<sup>4</sup> operation, typical.

**Bounce time NO / NC contact:** 4 / 10 ms, typical.

**Frequency response:** 10 Hz maximum.

**Compatibility:**

**CE** CE mark compliant, conforms to 2004/108/CE EMC Directive.

**Environmental conditions:**

**Operating:** temperature limits - 40 to + 60 °C, relative humidity 95 %, up to 55 °C.

**Storage:** temperature limits - 45 to + 80 °C.

**Approvals:**



TUV Certificate No. C-IS-204194-01, SIL 3 conforms to IEC61508.

**Mounting:**

T35 DIN-Rail according to EN50022.

**Weight:** about 145 g.

**Connection:** by polarized plug-in disconnect screw terminal blocks to accommodate terminations up to 2.5 mm<sup>2</sup>.

**Location:** Safe Area installation.

**Protection class:** IP 20.

**Dimensions:** Width 22.5 mm, Depth 123 mm, Height 120 mm.

**Front Panel and Features:**



- SIL 3 according to IEC 61508 for 10 years life time (10 % or more of total SIF).
- PFDavg (1 year) 7.01 E-06, SFF 99.37 % for NE Load.
- 10 A SIL 3 contact for NE load and contact for service purpose.
- Input/Output isolation.
- EMC Compatibility to EN61000-6-2, EN61000-6-4, EN61326-1, EN61326-3-1 for safety system.
- Simplified installation using standard DIN-Rail.

**Ordering Information:**

Model: D5290S-080

**Image:**



**Function Diagram:**

SAFE AREA

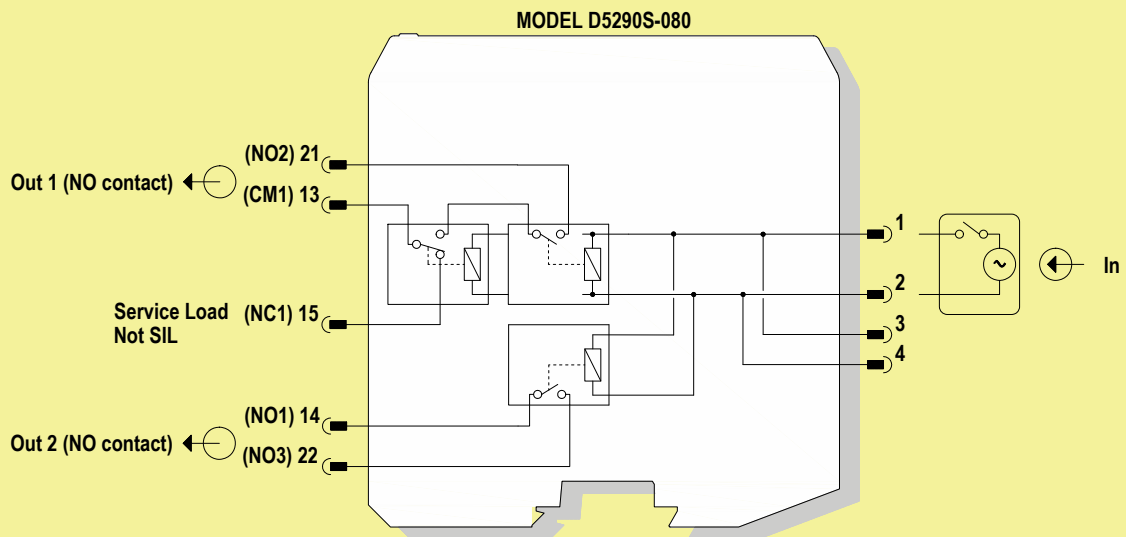

See the following pages for Functional Safety applications with related SIL value.

Relay contact shown in de-energized position.  
Terminals 13-21 and 14-22 are open; terminal 13-15 is closed.

Application D5290S-080 - SIL 3 Load Normally Energized Condition (NE) and Normally Energized Relay, with interruption of both load supply lines

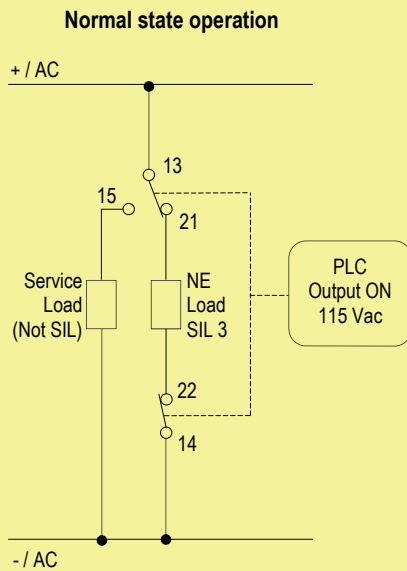

**Contacts 13-21 and 14-22:** in normal operation relays are energized, contacts are closed, NE load is energized.  
**Contact 13-15:** in normal operation relay is energized, contact is open, service load for NE load is de-energized.

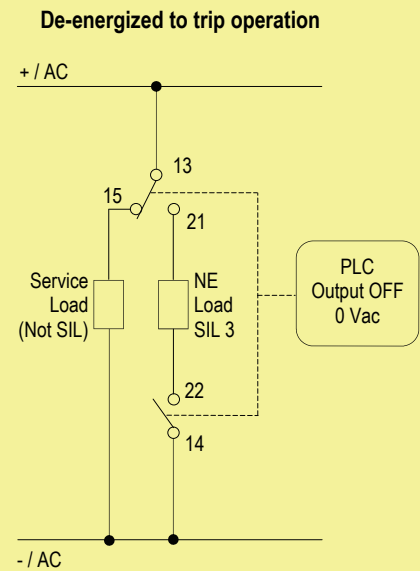

**Contacts 13-21 and 14-22:** the SIL 3 Safety Function is met when the relays are de-energized, contacts are open, NE load is de-energized.  
**Contact 13-15:** in safe state the relay is de-energized, contact is closed, service load for NE load is energized.

**Application D5290S-080 - SIL 3 Load Normally Energized Condition (NE) and Normally Energized Relay, with interruption of only one load supply line**

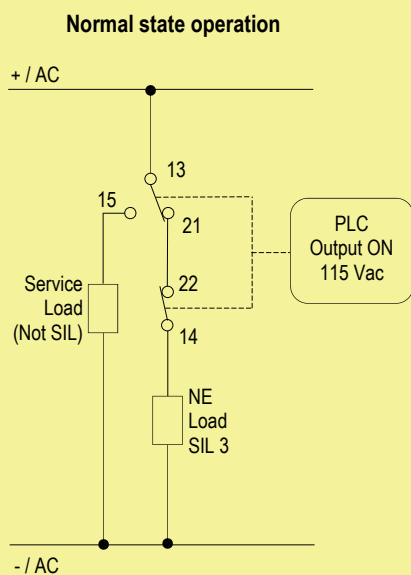

**Contacts 13-21 and 14-22:** in normal operation relays are energized, contacts are closed, NE load is energized.  
**Contact 13-15:** in normal operation relay is energized, contact is open, service load for NE load is de-energized.

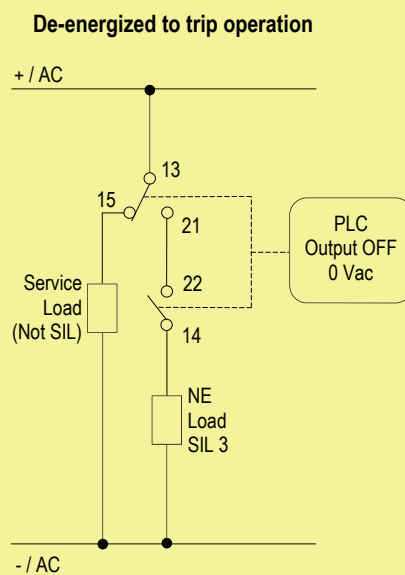

**Contacts 13-21 and 14-22:** the SIL 3 Safety Function is met when the relays are de-energized, contacts are open, NE load is de-energized.  
**Contact 13-15:** in safe state the relay is de-energized, contact is closed, service load for NE load is energized.